

Reciprocating pumps

Performs better, lasts longer, operates efficiently



Oil & gas pumps

TechnipFMC Pumps are manufactured in our US based ISO-9001 and API Certified cutting-edge facility using the latest in advanced technology. Our state-of-the-art 3D CAD/CAM systems, operated by experience professionals, ensure that each component is machined to the most precise specifications increasing consistency across the pump product offering. We continue to invest in Research and Development to refine existing products, tackle new applications and create reliable, durable and efficient pumps for the markets we serve.

Proven reliability since 1884

Reciprocating pumps have been a major part of TechnipFMC's legacy since 1884, when John Bean developed the first continuous spray pump to combat orchard scale. Through the years, we have grown in many different industries to become the innovative solution for solving customers most difficult challenges.



Contents

Model	Page No.
D04	10
M06	12
M08	16
M12	20
M13	24
M14	26
M16	30
M18	34
Q16	38
Q18	42
M28	46
Q28	50
Q32	54
Notes/special options	58

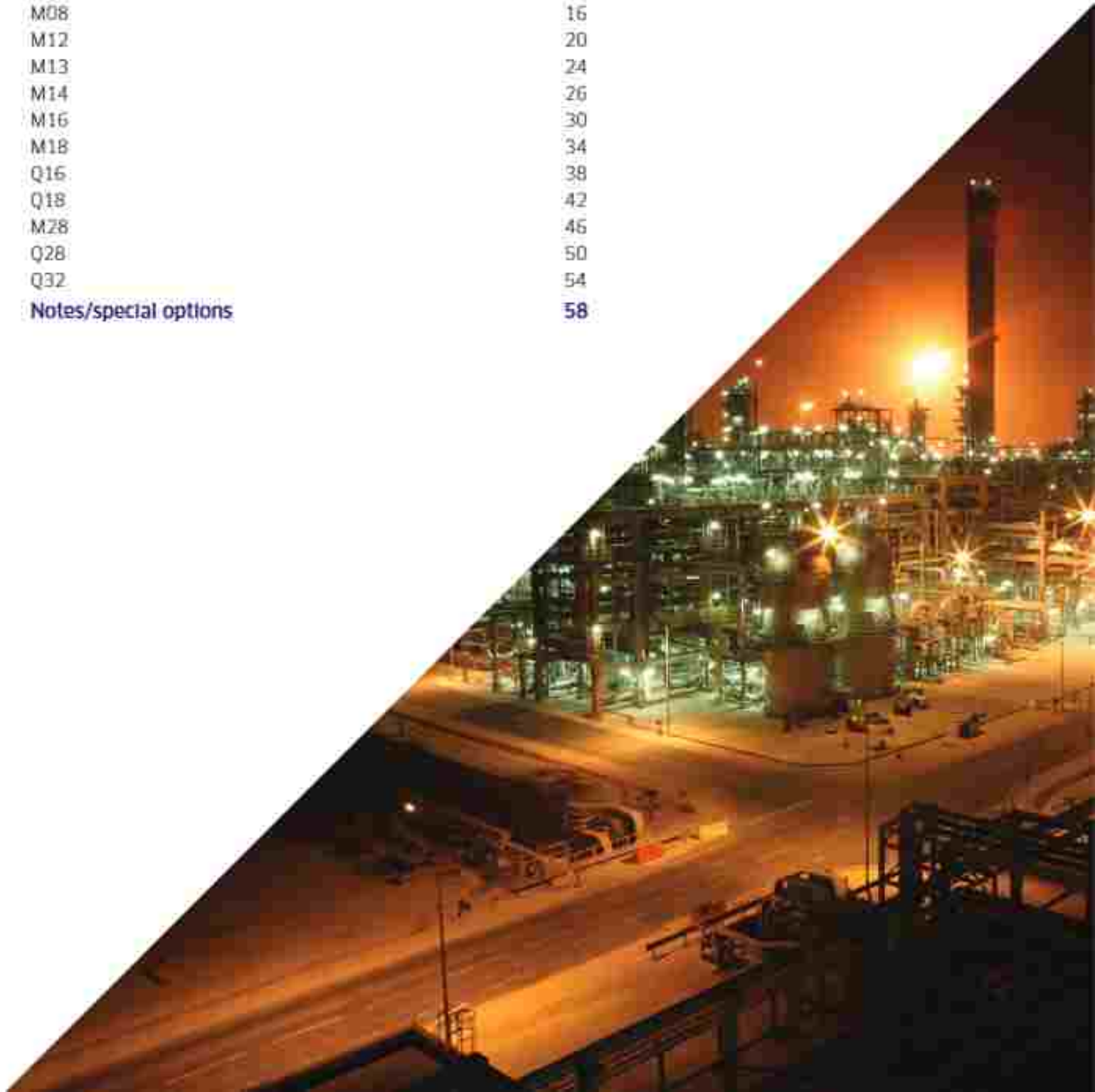

History

TechnipFMC has a 130-year history of experience in developing pumps for various pump applications. This legacy of market recognition that our products have set the performance and technical standards has enabled us to become the market leader. Even with this knowledge of our pumps being the standard; we continue to believe the best is yet to come. This commitment to a customer center approach and open collaboration will continue to lead us towards developing innovative products that increase productivity, lower the cost of ownership and maximizes customer profits.

At TechnipFMC, we encourage focused creativity and selfless risk taking to create everyday solutions for customer success. Our capabilities incorporate brilliantly engineered products with robust manufacturing and dependable delivery times. In other words, we commit to develop a quality product that exceeds our customers' requirements, is competitively priced and is delivered on time.

We believe the heart of our business comes from serving our customers. As a partner of TechnipFMC, you gain access to a network of experienced professionals dedicated to support throughout the life of the product. We understand that the life blood of innovation comes from our customers and by keeping them first, we keep them ahead.

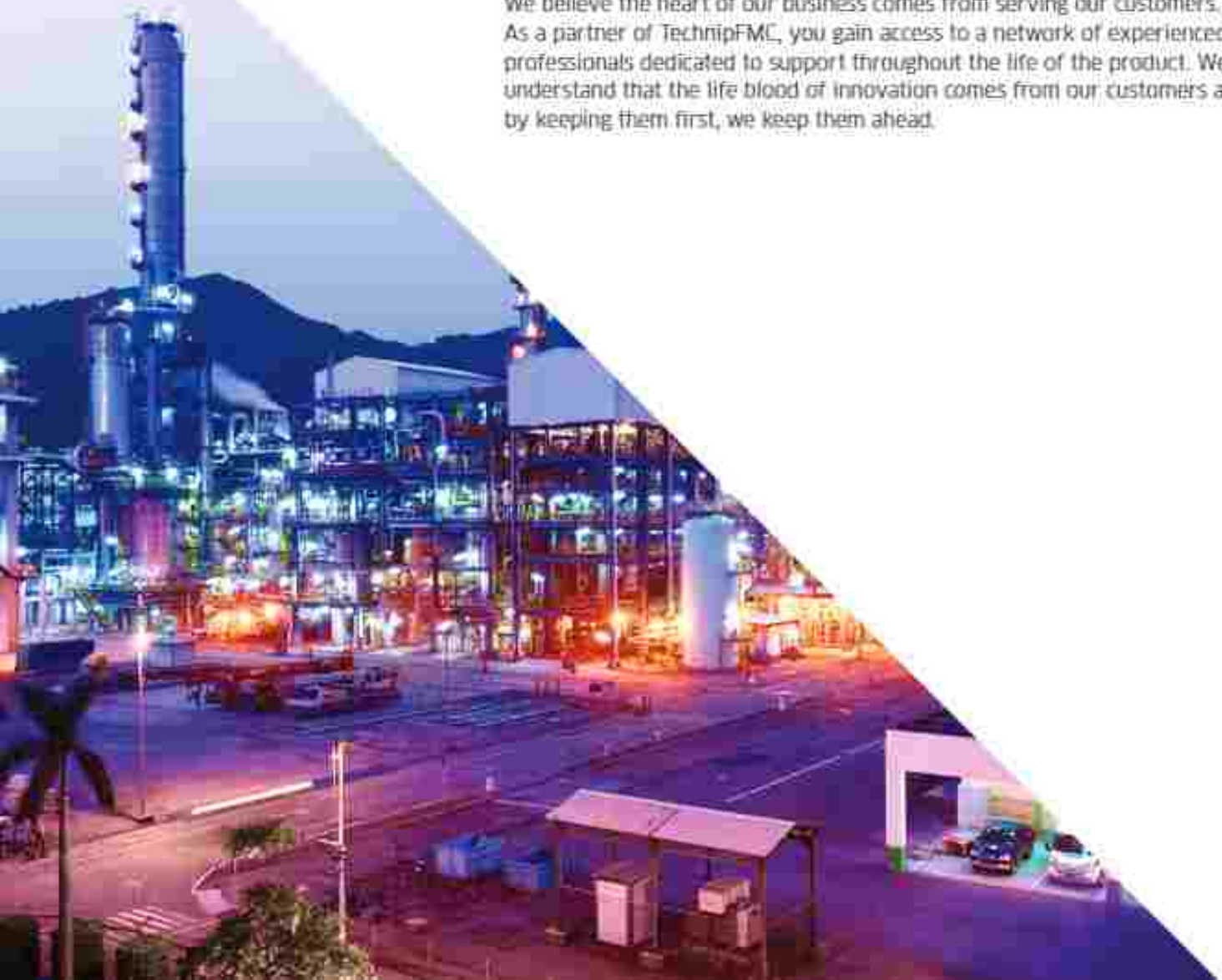

Challenges

TechnipFMC's complete line of pumps for the oil and gas industry are designed to perform better, last longer, and operate flawlessly under the most difficult conditions.

The oil and gas industry presents many challenges and opportunities regarding the use of pumps. The applications may be different, but the underlying principles are the same: you must have reliable, tough and quality pumps to get the job done.

Unlike other pumps in the oil and gas market, TechnipFMC's API 674 pumps will improve your bottom line saving you time and money. This is accomplished with recognized industry leading durability, and maintenance minded design resulting in simplified asset management and less downtime.

Because our pumps are designed specifically for applications within the oil and gas market segment, they are tested and re-tested under the same conditions that they will be performing in the field. The result: a time-tested line of pumps that are durable, field-proven, and innovative.

TechnipFMC has long been the leader in innovation. Because of this, our pumps are designed to have the lowest cost of ownership and highest return on investment in the industry.

How do we do it? Simple. We listen to our customers. Since the 1990s, the TechnipFMC team has worked

to design, build, and continually perfect a broad offering of piston and plunger pumps that require less service, perform in demanding conditions, produce high flow rates, and have an extended life cycle.

In addition, we have a dedicated engineering department and a dedicated support network that partners with our customers to create solutions. Our in-house product Research and Development department is focused on designing products to ensure customer success. We work with you to customize your pump specifically to your requirements.

Applications

TechnipFMC offers a diverse line of pumps for oil and gas, each with its own set of industry-leading features, including heavy-duty power ends paired with main journal roller bearings and heavy duty rod journal bearings, heavy-duty crankshafts, fluid cylinders designed so packing and valves are easily accessible, and customized pumps made to order. With pressure ranges up to 10,000 psi and flow rates up to 1,500 gpm, our pumps can handle any job in virtually any conditions.

For those in **BLOWOUT PREVENTION** who are looking for a solution to recurring downtime, our line of blowout prevention pumps feature an economic ductile iron fluid cylinder design.

SALTWATER DISPOSAL always has its own set of unique demands.

For that segment of the industry, TechnipFMC offers pumps with desirable options such as Cast aluminum bronze and forged duplex SST fluid cylinders with the option for a lubricated stuffing box, which will provide years of service to your production site.

TechnipFMC's API 674-3rd Edition pumps in both the **PIPELINE BOOSTING** process and the **POLYMER INJECTION** process will also improve your bottom line because of the speed and ease of maintenance. The most durable pump on the market has duplex SST fluid cylinders, abrasive resistant valve design and crosshead lubrication to allow our pumps to operate at a slower RPM.

Our superior pumps also address the **GLYCOL INJECTION/DEHYDRATION** process as well. The TechnipFMC line of glycol injection/dehydration pumps have high temp capability utilizing metal-seated valve designs and leak return-to-suction.

All of our pumps are supported by a staff of dedicated engineers, customer service professionals and others who use a team approach to maximize proven solutions to whatever situation may arise.

Section 2 Oil & Gas Pumps

Page number	Pump size (hp)	Model	Rated pressure (psig)	Continuous duty capacity	Intermittent duty capacity	Gallons per revolution				
						DI	AB	CS	AS	DX
10	D04 2.7/3.2 HP	D0404	4,000	0.85 GPM @ 500 RPM	1.02 GPM @ 600 RPM	0.0017				*
		D0406	2,630	1.91 GPM @ 500 RPM	2.29 GPM @ 600 RPM	0.0038			*	*
		D0408	1,480	3.40 GPM @ 500 RPM	4.08 GPM @ 600 RPM	0.0068			*	*
		D0410	950	5.31 GPM @ 500 RPM	6.37 GPM @ 600 RPM	0.0106			*	*
12	M06 16.6/20.9 HP	M0604	10,000	1.8 GPM @ 475 RPM	2.3 GPM @ 600 RPM	0.0038				*
		M0605	8,800	2.9 GPM @ 475 RPM	3.6 GPM @ 600 RPM	0.0060				*
		M0606	6,100	4.1 GPM @ 475 RPM	5.2 GPM @ 600 RPM	0.0086			*	*
		M0608	3,400	7.3 GPM @ 475 RPM	9.2 GPM @ 600 RPM	0.0153	*		*	*
		M0610	2,200	11.4 GPM @ 475 RPM	14.3 GPM @ 600 RPM	0.0239	*		*	*
		M0612	1,500	16.3 GPM @ 475 RPM	20.6 GPM @ 600 RPM	0.0344	*		*	*
		M0614	1,120	22.3 GPM @ 475 RPM	28.1 GPM @ 600 RPM	0.0469	*		*	*
		M0615	1,000	25.6 GPM @ 475 RPM	32.3 GPM @ 600 RPM	0.0538	*		*	*
16	M08 34/45 HP	M0806	10,000	5.2 GPM @ 450 RPM	6.9 GPM @ 600 RPM	0.0115				*
		M0807	7,400	7.0 GPM @ 450 RPM	9.4 GPM @ 600 RPM	0.0156				*
		M0808	5,650	9.0 GPM @ 450 RPM	12.2 GPM @ 600 RPM	0.0204			*	*
		M0810	3,620	14.4 GPM @ 450 RPM	19.1 GPM @ 600 RPM	0.0319	*		*	*
		M0812	2,250	20.7 GPM @ 450 RPM	27.5 GPM @ 600 RPM	0.0459	*	*	*	*
		M0814	1,850	28.1 GPM @ 450 RPM	37.5 GPM @ 600 RPM	0.0625	*	*	*	*
		M0816	1,420	36.7 GPM @ 450 RPM	49.0 GPM @ 600 RPM	0.0816	*	*	*	*
		M0818	1,120	46.5 GPM @ 450 RPM	62.0 GPM @ 600 RPM	0.1033	*	*	*	*
20	M12 62/77 HP	M1207	10,000	9.4 GPM @ 400 RPM	11.7 GPM @ 500 RPM	0.0234				*
		M1208	7,600	12.2 GPM @ 400 RPM	15.3 GPM @ 500 RPM	0.0306				*
		M1210	4,900	19.1 GPM @ 400 RPM	23.9 GPM @ 500 RPM	0.0478			*	*
		M1212	3,400	27.5 GPM @ 400 RPM	34.4 GPM @ 500 RPM	0.0688	*	*	*	*
		M1214	2,500	37.5 GPM @ 400 RPM	46.9 GPM @ 500 RPM	0.0937	*	*	*	*
		M1216	1,900	49.0 GPM @ 400 RPM	61.2 GPM @ 500 RPM	0.1224	*	*	*	*
		M1218	1,500	62.0 GPM @ 400 RPM	77.5 GPM @ 500 RPM	0.1549	*	*	*	*
		M1220	1,250	76.5 GPM @ 400 RPM	95.6 GPM @ 500 RPM	0.1912	*	*	*	*
		M1222	1,000	92.6 GPM @ 400 RPM	115.7 GPM @ 500 RPM	0.2314	*	*	*	*
		M1224	850-1	10.2 GPM @ 400 RPM	137.7 GPM @ 500 RPM	0.2754	*	*	*	*
24	M13 84/108 HP	M1308	10,000	12.8 GPM @ 387 RPM	16.6 GPM @ 500 RPM	0.0332				*
		M1310	6,450	20.0 GPM @ 387 RPM	25.9 GPM @ 500 RPM	0.0518				*
		M1312	4,470	28.9 GPM @ 387 RPM	37.3 GPM @ 500 RPM	0.0746			*	*
		M1314	3,280	39.3 GPM @ 387 RPM	50.8 GPM @ 500 RPM	0.1015	*	*	*	*
		M1316	2,500	51.3 GPM @ 387 RPM	66.3 GPM @ 500 RPM	0.1326	*	*	*	*
		M1318	2,000	65.0 GPM @ 387 RPM	83.9 GPM @ 500 RPM	0.1678	*	*	*	*
		M1320	1,600	80.2 GPM @ 387 RPM	103.6 GPM @ 500 RPM	0.2072	*	*	*	*
		M1322	1,330	97.0 GPM @ 387 RPM	125.4 GPM @ 500 RPM	0.2507	*	*	*	*
		M1324	1,120	115.5 GPM @ 387 RPM	149.2 GPM @ 500 RPM	0.2983	*	*	*	*
		M1326	950	135.5 GPM @ 387 RPM	175.1 GPM @ 500 RPM	0.3501	*	*	*	*

DI Cast ductile iron

CS Forged carbon steel

DX Forged duplex stainless steel

AB Cast aluminum bronze

AS Forged alloy steel

Page number	Pump series	Model	Rated pressure (psig)	Continuous duty capacity	Intermittent duty capacity	Gallons per revolution	DI	AB	CS	AS	DX		
26	M14 88/104 HP	M1408	10,000	13.4 GPM @ 375 RPM	15.5 GPM @ 425 RPM	0.0357					▶		
		M1410	6,500	20.9 GPM @ 375 RPM	23.7 GPM @ 425 RPM	0.0558				▶	▶	▶	
		M1412	4,500	30.1 GPM @ 375 RPM	34.1 GPM @ 425 RPM	0.0803				▶	▶	▶	
		M1414	3,300	41.0 GPM @ 375 RPM	46.5 GPM @ 425 RPM	0.1093				▶	▶	▶	
		M1416	2,500	53.6 GPM @ 375 RPM	60.7 GPM @ 425 RPM	0.1428				▶	▶	▶	
		M1418	2,000	67.8 GPM @ 375 RPM	76.8 GPM @ 425 RPM	0.1807	▶			▶	▶	▶	
		M1420	1,600	83.7 GPM @ 375 RPM	94.8 GPM @ 425 RPM	0.2231	▶			▶	▶	▶	
		M1422	1,350	101.3 GPM @ 375 RPM	114.8 GPM @ 425 RPM	0.2700	▶			▶	▶	▶	
		M1424	1,150	120.5 GPM @ 375 RPM	136.6 GPM @ 425 RPM	0.3213	▶			▶	▶	▶	
		M1426	1,000	141.4 GPM @ 375 RPM	160.3 GPM @ 425 RPM	0.3771	▶			▶	▶	▶	
		M1428	825	164.0 GPM @ 375 RPM	185.9 GPM @ 425 RPM	0.4373	▶			▶	▶	▶	
		M1430	725	188.3 GPM @ 375 RPM	213.4 GPM @ 425 RPM	0.5070	▶			▶	▶	▶	
		M1432	630	214.2 GPM @ 375 RPM	242.7 GPM @ 425 RPM	0.5712	▶			▶	▶	▶	
30	M16 117/142 HP	M1609	10,000	18.1 GPM @ 350 RPM	21.9 GPM @ 425 RPM	0.0516					▶		
		M1610	8,000	22.3 GPM @ 350 RPM	27.1 GPM @ 425 RPM	0.0637					▶	▶	
		M1612	5,500	32.1 GPM @ 350 RPM	39.0 GPM @ 425 RPM	0.0918					▶	▶	
		M1614	4,065	43.7 GPM @ 350 RPM	53.1 GPM @ 425 RPM	0.1249					▶	▶	▶
		M1616	3,115	57.1 GPM @ 350 RPM	69.4 GPM @ 425 RPM	0.1632	▶				▶	▶	▶
		M1618	2,460	72.3 GPM @ 350 RPM	87.8 GPM @ 425 RPM	0.2065	▶				▶	▶	▶
		M1620	1,990	89.3 GPM @ 350 RPM	108.4 GPM @ 425 RPM	0.2550	▶				▶	▶	▶
		M1622	1,650	108.0 GPM @ 350 RPM	131.1 GPM @ 425 RPM	0.3085	▶				▶	▶	▶
		M1624	1,385	128.5 GPM @ 350 RPM	156.1 GPM @ 425 RPM	0.3672	▶				▶	▶	▶
		M1626	1,180	150.8 GPM @ 350 RPM	183.1 GPM @ 425 RPM	0.4309	▶				▶	▶	▶
		M1628	1,015	174.9 GPM @ 350 RPM	212.4 GPM @ 425 RPM	0.4998	▶				▶	▶	▶
		M1630	885	200.8 GPM @ 350 RPM	243.8 GPM @ 425 RPM	0.5737	▶				▶	▶	▶
		M1632	775	228.5 GPM @ 350 RPM	277.4 GPM @ 425 RPM	0.6528	▶				▶	▶	▶
M1634	650	257.9 GPM @ 350 RPM	313.2 GPM @ 425 RPM	0.7369	▶				▶	▶	▶		
M1636	570	289.2 GPM @ 350 RPM	351.1 GPM @ 425 RPM	0.8262	▶				▶	▶	▶		
34	M18 150/190 HP	M1810	9,800	23.7 GPM @ 330 RPM	28.7 GPM @ 400 RPM	0.0717					▶		
		M1812	6,800	34.1 GPM @ 330 RPM	41.3 GPM @ 400 RPM	0.1033					▶	▶	
		M1814	5,000	46.4 GPM @ 330 RPM	56.2 GPM @ 400 RPM	0.1406					▶	▶	▶
		M1816	3,800	60.6 GPM @ 330 RPM	73.4 GPM @ 400 RPM	0.1836					▶	▶	▶
		M1818	3,000	76.7 GPM @ 330 RPM	93.0 GPM @ 400 RPM	0.2324	▶				▶	▶	▶
		M1820	2,400	94.7 GPM @ 330 RPM	114.8 GPM @ 400 RPM	0.2869	▶				▶	▶	▶
		M1822	2,000	114.5 GPM @ 330 RPM	138.8 GPM @ 400 RPM	0.3471	▶				▶	▶	▶
		M1824	1,700	136.3 GPM @ 330 RPM	165.2 GPM @ 400 RPM	0.4131	▶				▶	▶	▶
		M1826	1,400	160.0 GPM @ 330 RPM	193.9 GPM @ 400 RPM	0.4848	▶				▶	▶	▶
		M1828	1,200	185.6 GPM @ 330 RPM	224.9 GPM @ 400 RPM	0.5623	▶				▶	▶	▶
		M1830	1,100	213.0 GPM @ 330 RPM	258.2 GPM @ 400 RPM	0.6455	▶				▶	▶	▶
		M1832	1,000	242.4 GPM @ 330 RPM	293.8 GPM @ 400 RPM	0.7344	▶				▶	▶	▶
		M1834	800	273.6 GPM @ 330 RPM	331.6 GPM @ 400 RPM	0.8291	▶				▶	▶	▶
M1836	750	306.7 GPM @ 330 RPM	371.8 GPM @ 400 RPM	0.9295	▶				▶	▶	▶		

DI Cast ductile iron

CS Forged carbon steel

DX Forged duplex stainless steel

AB Cast aluminum bronze

AS Forged alloy steel

Section 2 Oil & Gas Pumps

Page number	Pump size (hp)	Model	Rated pressure (psig)	Continuous duty capacity	Intermittent duty capacity	Gallons per revolution	DI	AB	CS	AS	DX
38	Q16 198/240 HP	Q1609	10,000	30.1 GPM @ 350 RPM	36.6 GPM @ 425 RPM	0.0861					*
		Q1610	8,150	37.2 GPM @ 350 RPM	45.1 GPM @ 425 RPM	0.1062					*
		Q1612	5,650	53.6 GPM @ 350 RPM	65.0 GPM @ 425 RPM	0.1530					*
		Q1614	4,160	72.9 GPM @ 350 RPM	88.5 GPM @ 425 RPM	0.2082					*
		Q1616	3,190	95.2 GPM @ 350 RPM	115.6 GPM @ 425 RPM	0.2720					*
		Q1618	2,520	120.5 GPM @ 350 RPM	146.3 GPM @ 425 RPM	0.3442					*
		Q1620	2,040	148.8 GPM @ 350 RPM	180.6 GPM @ 425 RPM	0.4250					*
		Q1622	1,690	180.0 GPM @ 350 RPM	218.5 GPM @ 425 RPM	0.5142					*
		Q1624	1,420	214.2 GPM @ 350 RPM	260.1 GPM @ 425 RPM	0.6120					*
		Q1626	1,210	251.4 GPM @ 350 RPM	305.7 GPM @ 425 RPM	0.7182					*
		Q1628	1,040	291.6 GPM @ 350 RPM	354.0 GPM @ 425 RPM	0.8330					*
		Q1630	910	334.7 GPM @ 350 RPM	406.4 GPM @ 425 RPM	0.9562					*
		Q1632	800	380.8 GPM @ 350 RPM	462.4 GPM @ 425 RPM	1.0880					*
		Q1634	710	429.9 GPM @ 350 RPM	522.0 GPM @ 425 RPM	1.2282					*
Q1636	630	482.0 GPM @ 350 RPM	585.2 GPM @ 425 RPM	1.3770					*		
42	Q18 265/325 HP	Q1811	8,400	47.7 GPM @ 330 RPM	57.8 GPM @ 400 RPM	0.1446					*
		Q1812	7,100	56.8 GPM @ 330 RPM	68.8 GPM @ 400 RPM	0.1721					*
		Q1814	5,200	77.3 GPM @ 330 RPM	93.7 GPM @ 400 RPM	0.2343					*
		Q1816	4,000	101.0 GPM @ 330 RPM	122.4 GPM @ 400 RPM	0.3060					*
		Q1818	3,100	127.8 GPM @ 330 RPM	154.9 GPM @ 400 RPM	0.3873					*
		Q1820	2,500	157.6 GPM @ 330 RPM	191.7 GPM @ 400 RPM	0.4781					*
		Q1822	2,100	190.9 GPM @ 330 RPM	231.4 GPM @ 400 RPM	0.5785					*
		Q1824	1,800	227.2 GPM @ 330 RPM	275.4 GPM @ 400 RPM	0.6885					*
		Q1826	1,500	266.6 GPM @ 330 RPM	323.2 GPM @ 400 RPM	0.8080					*
		Q1828	1,300	309.2 GPM @ 330 RPM	374.8 GPM @ 400 RPM	0.9371					*
		Q1830	1,100	355.0 GPM @ 330 RPM	430.3 GPM @ 400 RPM	1.0758					*
		Q1832	1,000	403.9 GPM @ 330 RPM	489.6 GPM @ 400 RPM	1.2240					*
		Q1834	900	456.0 GPM @ 330 RPM	552.7 GPM @ 400 RPM	1.3818					*
		Q1836	800	511.2 GPM @ 330 RPM	619.6 GPM @ 400 RPM	1.5491					*
46	M28 350/440 HP	M2812	10,000	38.5 GPM @ 240 RPM	48.2 GPM @ 300 RPM	0.1606					*
		M2814	10,000	52.5 GPM @ 240 RPM	65.6 GPM @ 300 RPM	0.2187					*
		M2816	7,960	68.5 GPM @ 240 RPM	85.7 GPM @ 300 RPM	0.2856					*
		M2818	6,300	86.8 GPM @ 240 RPM	108.5 GPM @ 300 RPM	0.3615					*
		M2820	5,100	107.1 GPM @ 240 RPM	133.9 GPM @ 300 RPM	0.4462					*
		M2822	4,200	129.6 GPM @ 240 RPM	162.0 GPM @ 300 RPM	0.5400					*
		M2824	3,540	154.2 GPM @ 240 RPM	192.8 GPM @ 300 RPM	0.6426					*
		M2826	3,015	181.0 GPM @ 240 RPM	226.3 GPM @ 300 RPM	0.7542					*
		M2828	2,600	209.9 GPM @ 240 RPM	262.4 GPM @ 300 RPM	0.8746					*
		M2830	2,260	241.0 GPM @ 240 RPM	301.2 GPM @ 300 RPM	1.0041					*
		M2832	1,990	274.2 GPM @ 240 RPM	342.7 GPM @ 300 RPM	1.1424					*
		M2834	1,760	309.5 GPM @ 240 RPM	386.9 GPM @ 300 RPM	1.2897					*
		M2836	1,570	347.0 GPM @ 240 RPM	433.7 GPM @ 300 RPM	1.4458					*
		M2838	1,400	386.6 GPM @ 240 RPM	483.3 GPM @ 300 RPM	1.6110					*
		M2840	1,275	428.4 GPM @ 240 RPM	535.5 GPM @ 300 RPM	1.7850					*
		M2842	1,155	472.3 GPM @ 240 RPM	590.4 GPM @ 300 RPM	1.9680					*
		M2844	1,050	518.4 GPM @ 240 RPM	647.9 GPM @ 300 RPM	2.1598					*
		M2846	960	566.6 GPM @ 240 RPM	708.2 GPM @ 300 RPM	2.3607					*
M2848	880	616.9 GPM @ 240 RPM	771.1 GPM @ 300 RPM	2.5704					*		
M2850	815	669.4 GPM @ 240 RPM	836.7 GPM @ 300 RPM	2.7891					*		

Page number	Pump series	Model	Rated pressure (psig)	Continuous duty capacity	Intermittent duty capacity	Gallons per revolution	DI	AB	CS	AS	DX
50	Q28 650/800 HP	Q2814	10,000	87.5 GPM @ 240 RPM	109.3 GPM @ 300 RPM	0.2644					▶
		Q2816	8,750	114.2 GPM @ 240 RPM	142.8 GPM @ 300 RPM	0.4760					▶
		Q2818	6,920	144.6 GPM @ 240 RPM	180.7 GPM @ 300 RPM	0.6024					▶ ▶
		Q2820	5,600	178.5 GPM @ 240 RPM	223.1 GPM @ 300 RPM	0.7437					▶ ▶
		Q2822	4,630	216.0 GPM @ 240 RPM	270.0 GPM @ 300 RPM	0.8999					▶ ▶ ▶
		Q2824	3,890	257.0 GPM @ 240 RPM	321.3 GPM @ 300 RPM	1.0710					▶ ▶ ▶
		Q2826	3,210	301.7 GPM @ 240 RPM	377.1 GPM @ 300 RPM	1.2569					▶ ▶ ▶
		Q2828	2,860	349.8 GPM @ 240 RPM	437.3 GPM @ 300 RPM	1.4577					▶ ▶ ▶
		Q2830	2,490	401.6 GPM @ 240 RPM	502.0 GPM @ 300 RPM	1.6734					▶ ▶ ▶
		Q2832	2,190	457.0 GPM @ 240 RPM	571.2 GPM @ 300 RPM	1.9040					▶ ▶ ▶
		Q2834	1,940	515.9 GPM @ 240 RPM	644.8 GPM @ 300 RPM	2.1494					▶ ▶ ▶
		Q2836	1,730	578.3 GPM @ 240 RPM	722.9 GPM @ 300 RPM	2.4097					▶ ▶ ▶
		Q2838	1,550	644.4 GPM @ 240 RPM	805.5 GPM @ 300 RPM	2.6849					▶ ▶ ▶
		Q2840	1,400	714.0 GPM @ 240 RPM	892.5 GPM @ 300 RPM	2.9750					▶ ▶ ▶
		Q2842	1,270	787.2 GPM @ 240 RPM	984.0 GPM @ 300 RPM	3.2799					▶ ▶ ▶
		Q2844	1,160	863.9 GPM @ 240 RPM	1,079.9 GPM @ 300 RPM	3.5997					▶ ▶ ▶
		Q2846	1,060	944.3 GPM @ 240 RPM	1,180.3 GPM @ 300 RPM	3.9344					▶ ▶ ▶
Q2848	970	1,028.2 GPM @ 240 RPM	1,285.2 GPM @ 300 RPM	4.2840					▶ ▶ ▶		
Q2850	900	1,115.6 GPM @ 240 RPM	1,394.5 GPM @ 300 RPM	4.6484					▶ ▶ ▶		
54	Q32 700/1,000 HP	Q3214	10,000	87.5 GPM @ 210 RPM	125.0 GPM @ 300 RPM	0.4165					▶
		Q3216	9,550	114.2 GPM @ 210 RPM	163.2 GPM @ 300 RPM	0.5440					▶
		Q3218	7,500	144.6 GPM @ 210 RPM	206.6 GPM @ 300 RPM	0.6885					▶
		Q3220	6,125	178.5 GPM @ 210 RPM	255.0 GPM @ 300 RPM	0.8500					▶
		Q3222	5,050	216.0 GPM @ 210 RPM	308.6 GPM @ 300 RPM	1.0285					▶ ▶ ▶
		Q3224	4,250	257.0 GPM @ 210 RPM	367.2 GPM @ 300 RPM	1.2240					▶ ▶ ▶
		Q3226	3,620	301.7 GPM @ 210 RPM	431.0 GPM @ 300 RPM	1.4365					▶ ▶ ▶
		Q3228	3,125	349.9 GPM @ 210 RPM	499.8 GPM @ 300 RPM	1.6660					▶ ▶ ▶
		Q3230	2,720	401.6 GPM @ 210 RPM	573.8 GPM @ 300 RPM	1.9125					▶ ▶ ▶
		Q3232	2,390	457.0 GPM @ 210 RPM	652.8 GPM @ 300 RPM	2.1760					▶ ▶ ▶
		Q3234	2,110	515.9 GPM @ 210 RPM	737.0 GPM @ 300 RPM	2.4565					▶ ▶ ▶
		Q3236	1,890	578.3 GPM @ 210 RPM	826.2 GPM @ 300 RPM	2.7540					▶ ▶ ▶
		Q3238	1,690	644.4 GPM @ 210 RPM	920.6 GPM @ 300 RPM	3.0685					▶ ▶ ▶
		Q3240	1,530	714.0 GPM @ 210 RPM	1,020.0 GPM @ 300 RPM	3.4000					▶ ▶ ▶
		Q3242	1,390	787.2 GPM @ 210 RPM	1,124.6 GPM @ 300 RPM	3.7485					▶ ▶ ▶
		Q3244	1,260	863.9 GPM @ 210 RPM	1,234.2 GPM @ 300 RPM	4.1140					▶ ▶ ▶
		Q3246	1,160	944.3 GPM @ 210 RPM	1,349.0 GPM @ 300 RPM	4.4965					▶ ▶ ▶
Q3248	1,060	1,028.2 GPM @ 210 RPM	1,468.8 GPM @ 300 RPM	4.8960					▶ ▶ ▶		
Q3250	980	1,115.5 GPM @ 210 RPM	1,593.8 GPM @ 300 RPM	5.3125					▶ ▶ ▶		

DI Cast ductile iron

CS Forged carbon steel

DX Forged duplex stainless steel

AB Cast aluminum bronze

AS Forged alloy steel

D04

Specifications

Design Standard	API 674, Third Edition
Configuration	Horizontal Duplex Plunger
Number of Plungers	2
Continuous Duty	3.3 BHP
Intermittent Duty	3.9 BHP
Stroke Length	1.0 inches
Frame Load Rating	1,167 lbs.
Pump Weight (Average)	75 lbs.
Intermittent Duty Speed Rating	600 RPM
Continuous Duty Speed Rating	500 RPM
Minimum Speed	25 RPM
Mechanical Efficiency	90%
Lubrication System	Splash, Gravity Return
Crankcase Oil Capacity	1 Quart
Lube Oil Type	SAE 30
Fluid Temperature Range	-20 to 350 °F
Valve Type	Disc Valve

Forged ISO drawing

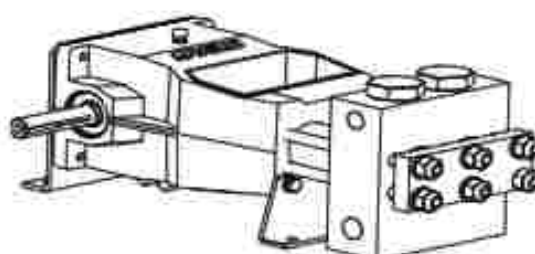

Standard connection sizes

Pump Model	Section (in)	Discharge (in)
00404 - 00408	0.75 - NPT	0.50 - NPT
00410	1.0 - NPT	0.75 - NPT

NPT connections available

Fluid cylinder materials

Forged	Cast
A350-LF2 Carbon Steel	Not Currently Available
Hi-Strength Carbon Alloy Steel	
2205 Duplex Stainless Steel	

Special materials available on request

Performance data

Pump Model	Plunger Diameter (in)	Displacement (GAL/REV)	Maximum Pressure #PSI	Pump Capacity (GPM) @ Input Speed (RPM)				
				100 RPM	250 RPM	400 RPM	500 RPM	600 RPM
00404	0.500	0.0017	4,000	0.17	0.42	0.68	0.85	1.02
00406	0.750	0.0038	2,630	0.38	0.96	1.53	1.91	2.29
00408	1.000	0.0068	1,480	0.68	1.70	2.72	3.40	4.08
00410	1.250	0.0106	950	1.06	2.66	4.25	5.31	6.37

D04

Forged pump engineering dimensional outline

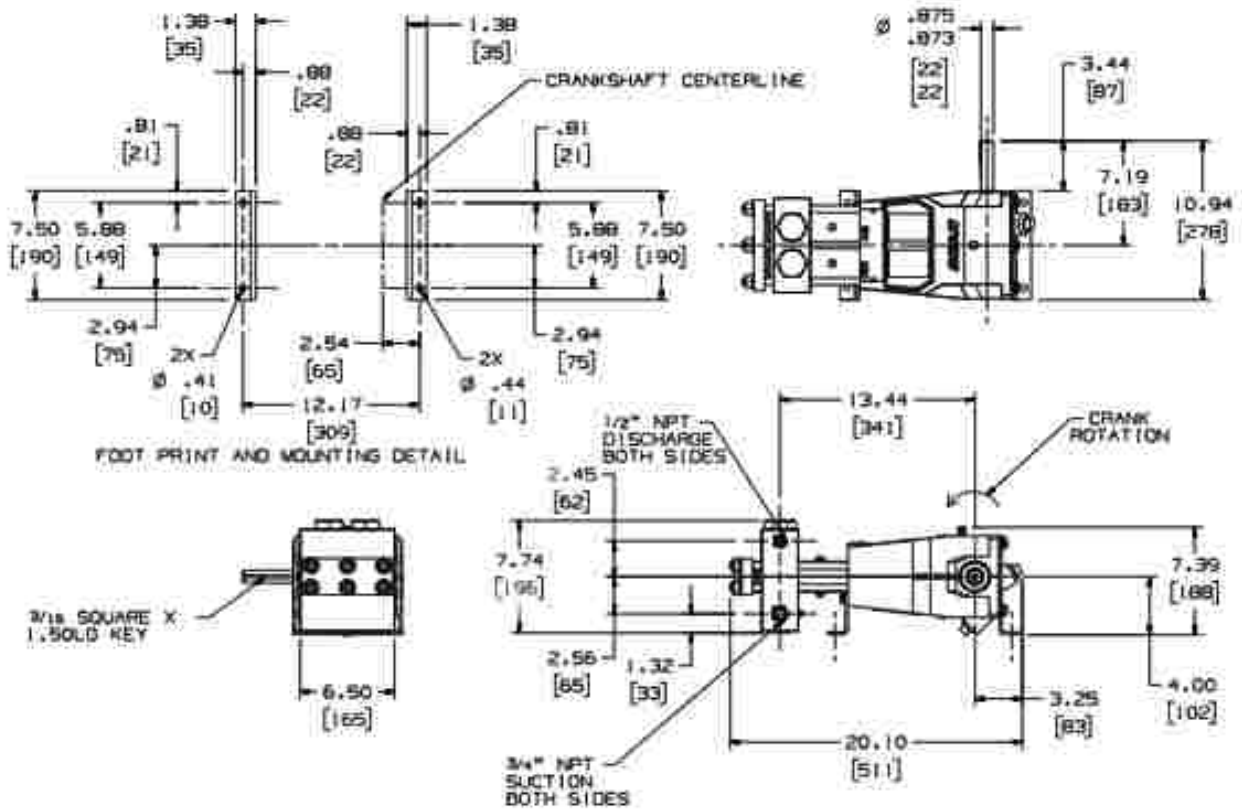

NPSHR value

Standard Disc Valves

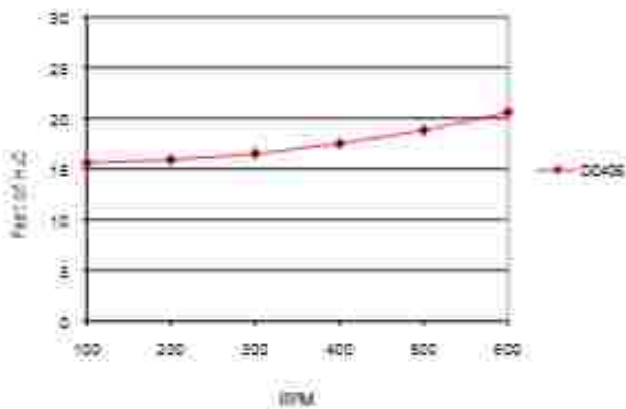

M06

Specifications

Design Standard	API 674, Third Edition
Configuration	Horizontal Triplex Plunger
Number of Plungers	3
Continuous Duty	16.6 BHP
Intermittent Duty	20.9 BHP
Stroke Length	1.5 inches
Frame Load Rating	2,700 lbs
Pump Weight (Average)	745 lbs
Intermittent Duty Speed Rating	600 RPM
Continuous Duty Speed Rating	475 RPM
Minimum Speed *	100 RPM
Mechanical Efficiency	90%
Lubrication System	Splash, Gravity Return
Lubrication System (Optional)	Pressurized
Crankcase Oil Capacity	2 Quarts
Lube Oil Type	SAE 30
Fluid Temperature Range	-20 to 350 °F
Valve Types	Disc Valves, Abrasion Resistant Valves

Slower RPM can be achieved with the addition of a pressurized lubrication system

Forged ISO drawing

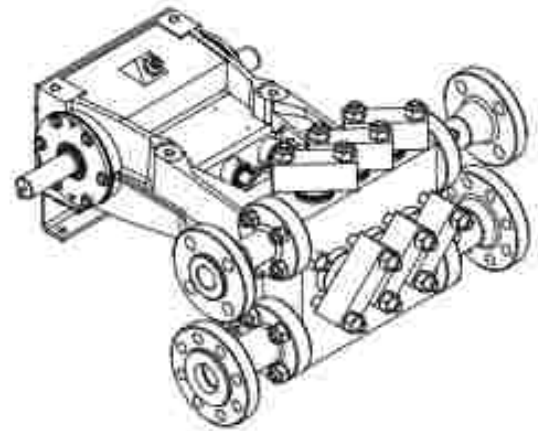

Cast ISO drawing

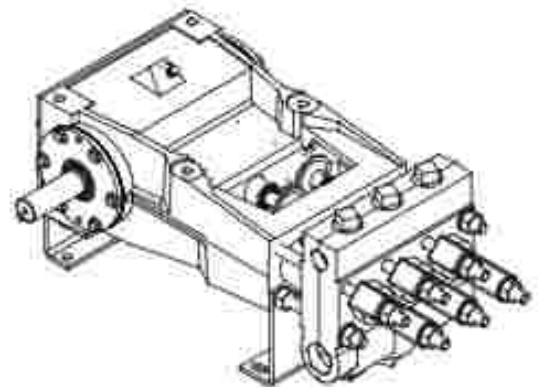

Performance data

Pump Model	Plunger Diameter (in)	Displacement (GAL/REV)	Maximum Pressure (PSI)	Pump Capacity (GPM) @ Input Speed (RPM)						
				100 RPM	200 RPM	300 RPM	400 RPM	475 RPM	500 RPM	600 RPM
M0604	0.500	0.0038	10,000	0.4	0.8	1.1	1.5	1.8	1.9	2.3
M0605	0.625	0.0060	8,800	0.6	1.2	1.8	2.4	2.9	3.0	3.6
M0606	0.750	0.0086	6,100	0.9	1.7	2.6	3.4	4.1	4.3	5.2
M0608	1.000	0.0153	3,400	1.5	3.1	4.6	6.1	7.3	7.7	9.2
M0610	1.250	0.0229	2,200	2.4	4.8	7.2	9.6	11.4	12.0	14.3
M0612	1.500	0.0344	1,500	3.4	6.9	10.3	13.8	16.3	17.2	20.6
M0614	1.750	0.0469	1,120	4.7	9.4	14.1	18.8	22.3	23.5	28.1
M0615	1.875	0.0538	1,000	5.4	10.8	16.1	21.5	25.6	26.9	32.3

M06

Standard connection sizes

Pump Model	Suction (in)	Discharge (in)
M0604-M0607	1.5	0.75
M0608-M0615	1.5	1.0
M0608-M0615 HV	2.0	1.5

NPT connections available

Fluid cylinder materials

Forged	Cast
A350-LF2 Carbon Steel	Ductile Iron
Hi-Strength Carbon Alloy Steel	
2205 Duplex Stainless Steel	

Special materials available on request

M06 NPSHr values

Disc Valves with 1-spring (Standard Stiffness)

For disc valves with stiff spring add 5ft.

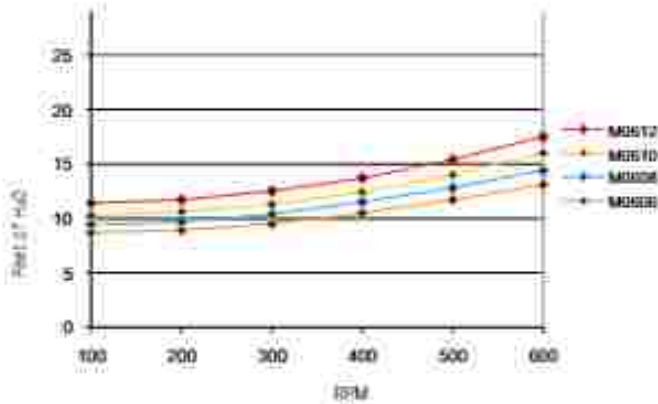

M0612 NPSHR Value

Disc Valves with 1-spring (Large Flow Valves)

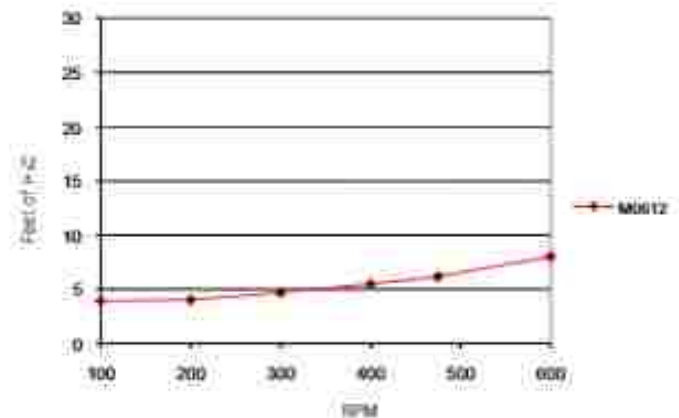

M0615 NPSHr values

Disc Valves with 1-spring

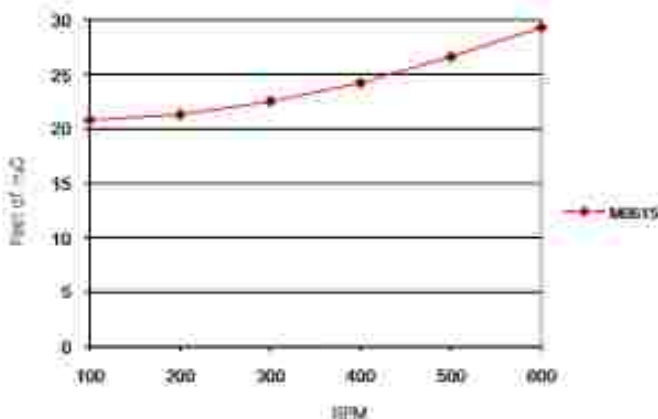

M06

Forged pump engineering dimensional outline

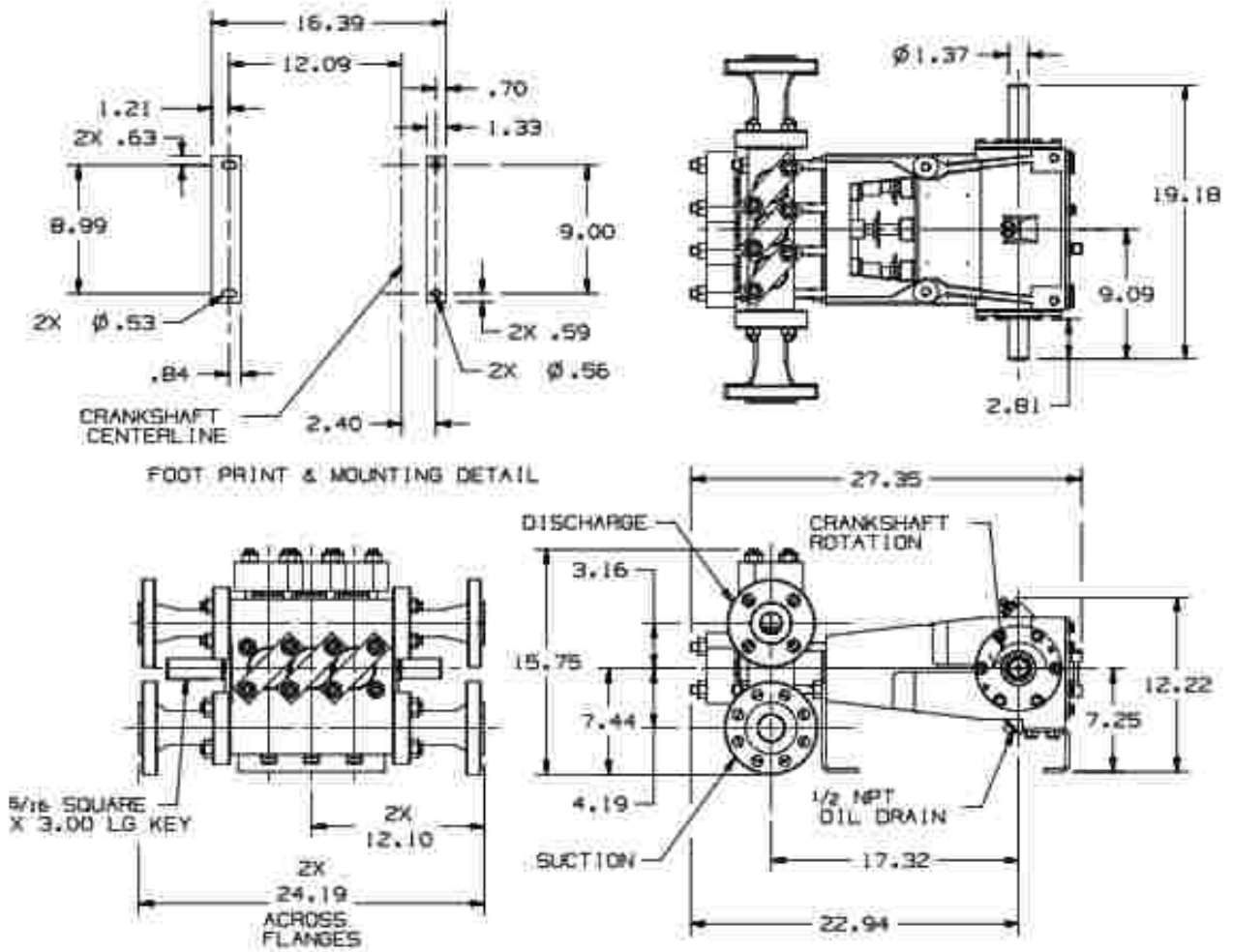

M06

Cast pump engineering dimensional outline

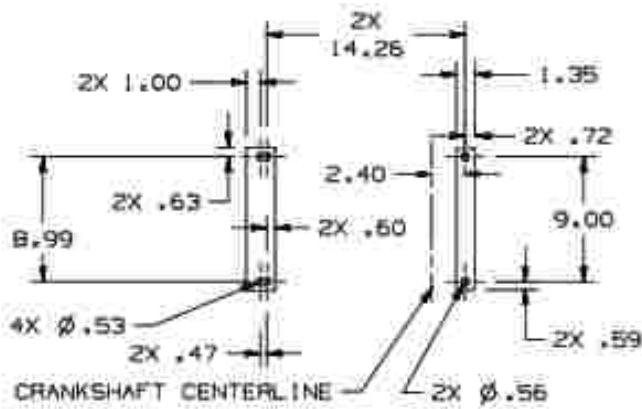

FOOT PRINT & MOUNTING DETAIL

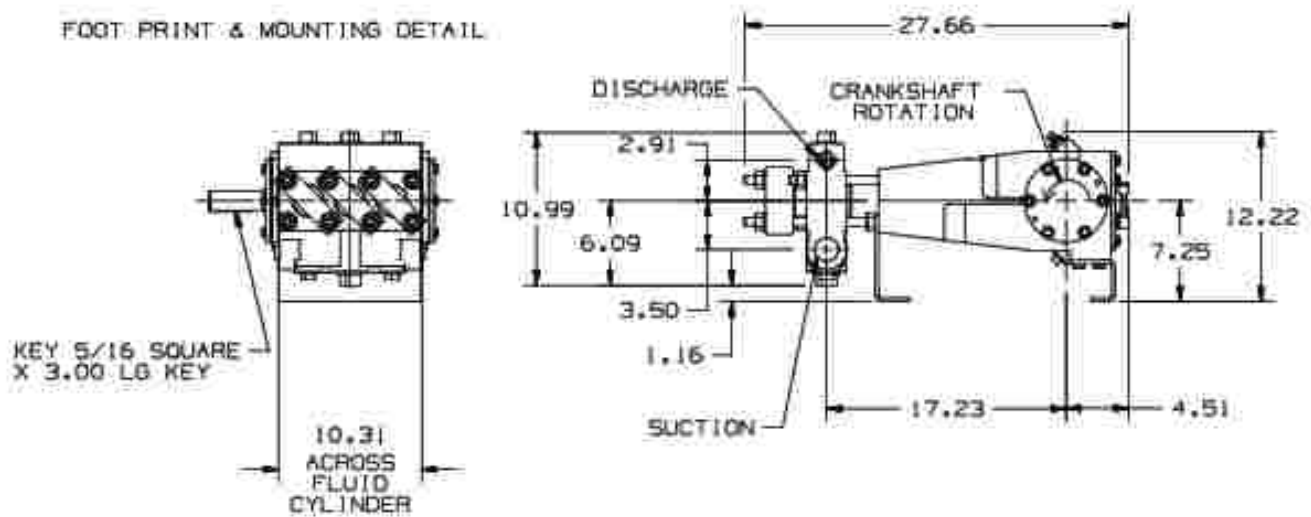
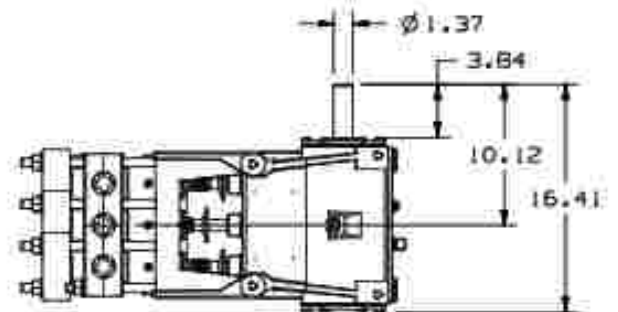

M08

Specifications

Design Standard	API 674, Third Edition
Configuration	Horizontal Triplex Plunger
Number of Plungers	3
Continuous Duty	34 BHP
Intermittent Duty	45 BHP
Stroke Length	2.0 inches
Frame Load Rating	4,450 lbs.
Pump Weight (Average)	550 lbs.
Intermittent Duty Speed Rating	600 RPM
Continuous Duty Speed Rating	450 RPM
Minimum Speed *	100 RPM
Mechanical Efficiency	90%
Lubrication System	Splash, Gravity Return
Crankcase Oil Capacity	1.75 Gallons
Lube Oil Type	SAE 30
Fluid Temperature Range	-20 to 350 °F
Valve Types	Disc Valves, Abrasion Resistant Valves

Slower RPM can be achieved with the addition of a pressurized lubrication system

Forged ISO drawing

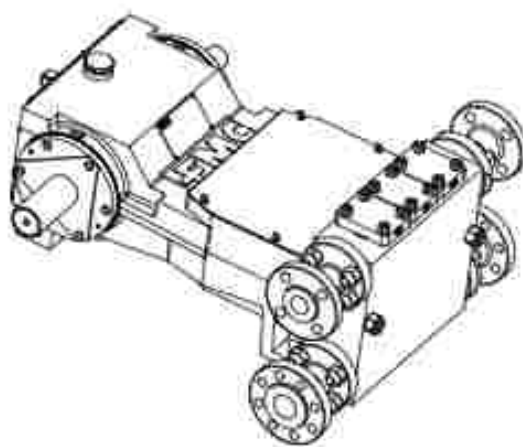

Cast ISO drawing

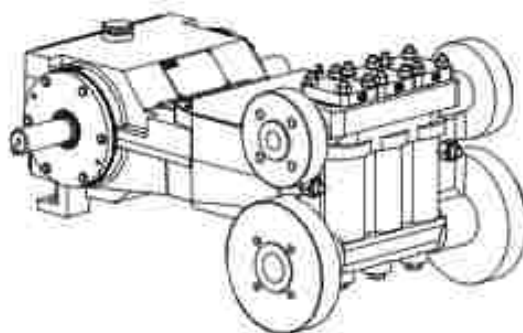

Performance data

Pump Model	Plunger Diameter (in)	Displacement (GAL/REV)	Maximum Pressure (PSI)	Pump Capacity (GPM) @ Input Speed (RPM)						
				100 RPM	200 RPM	300 RPM	400 RPM	450 RPM	500 RPM	600 RPM
M0806	0.750	0.0115	10,000	1.2	2.3	3.5	4.6	5.2	5.8	6.9
M0807	0.875	0.0156	7,400	1.6	3.1	4.7	6.2	7.0	7.8	9.4
M0808	1.000	0.0204	5,650	2.0	4.1	6.1	8.2	9.2	10.2	12.2
M0810	1.250	0.0319	3,620	3.2	6.4	9.6	12.8	14.4	16.0	19.1
M0812	1.500	0.0459	2,520	4.6	9.2	13.8	18.4	20.7	23.0	27.5
M0814	1.750	0.0625	1,850	6.3	12.5	18.8	25.0	28.1	31.3	37.5
M0816	2.000	0.0816	1,420	8.2	16.3	24.5	32.6	36.7	40.8	49.0
M0818	2.250	0.1033	1,120	10.3	20.7	31	41.3	46.5	51.7	62.0
M0820	2.500	0.1275	915	12.8	25.5	38.3	51.0	57.4	63.8	76.5

M08

Standard connection sizes

Pump Model	Suction (in)	Discharge (in)
M0806-M0808	1.5	0.75
M0809-M0820	2.0	1.5
M0815-M0820	2.5	1.5

NPT connections available

Fluid cylinder materials

Forged	Cast
A350 LF2 Carbon Steel	Ductile Iron
Hi-Strength Carbon Alloy Steel	Aluminum Bronze
2205 Duplex Stainless Steel	

Special materials available on request

M08 NPSHr values

Disc Valves with 2-springs

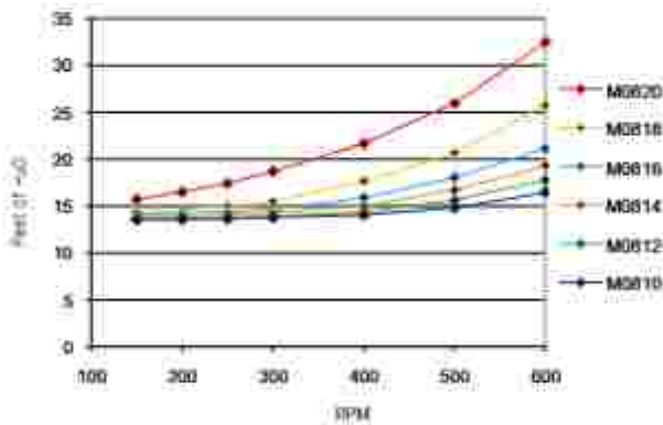

M08 NPSHr values

AR Valves with 1-spring

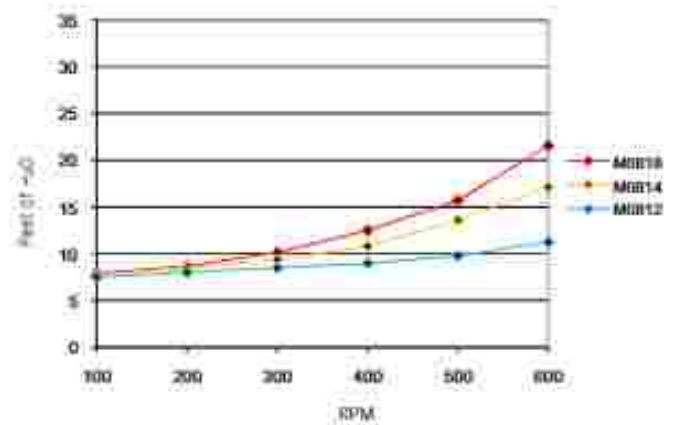

M08 NPSHr values

Disc Valves with 1-spring

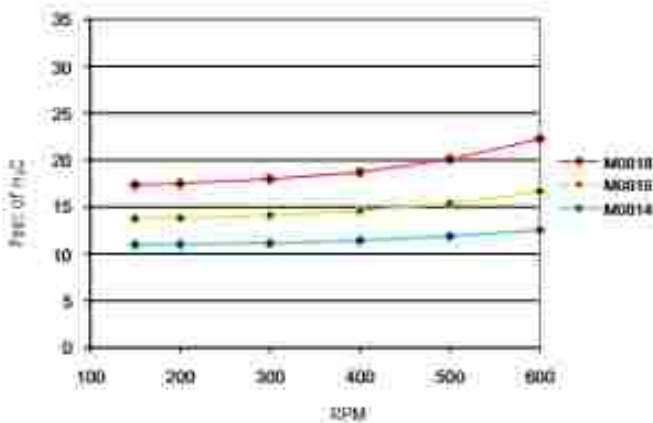

M08

Forged pump engineering dimensional outline

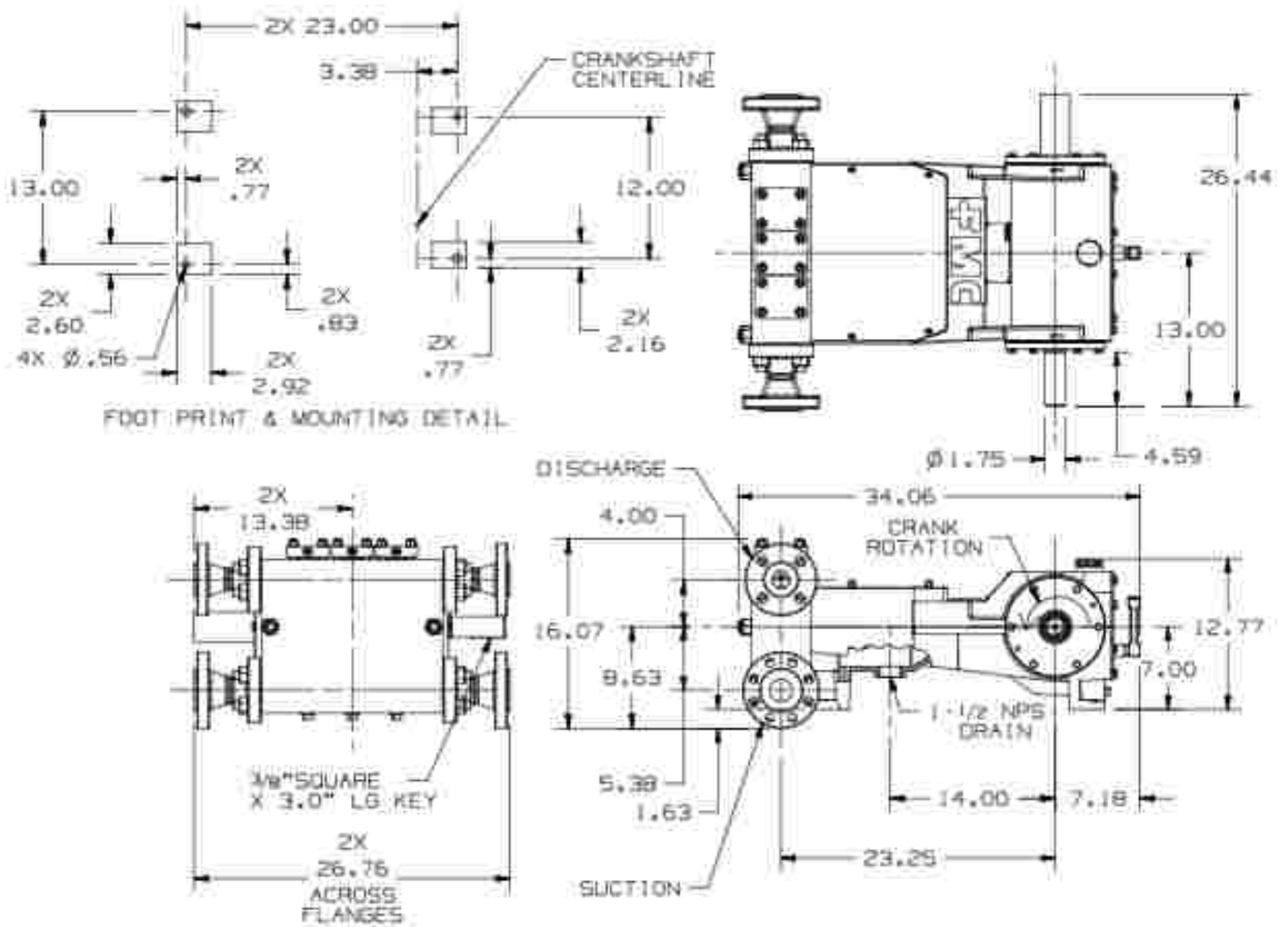

M08

Cast pump engineering dimensional outline

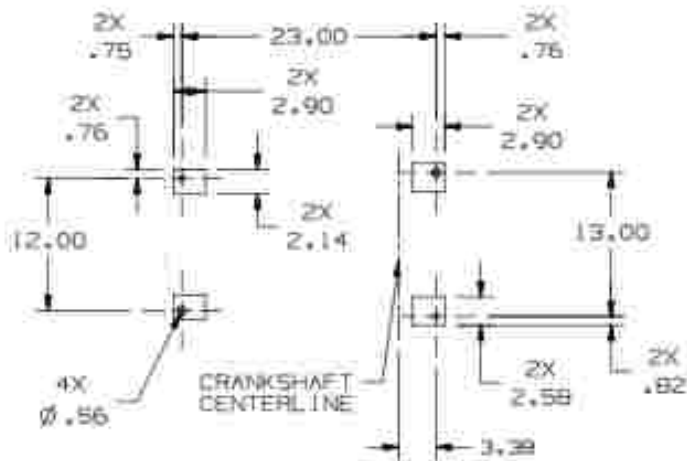

FOOT PRINT AND MOUNTING DETAIL

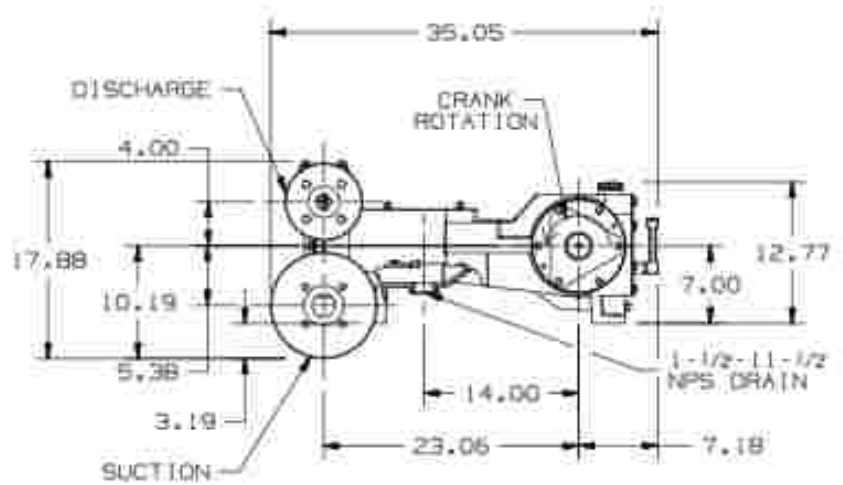
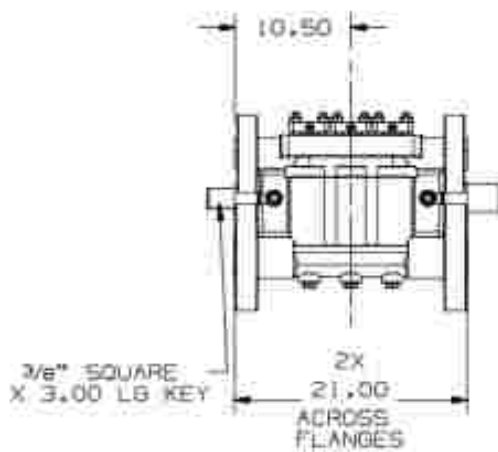
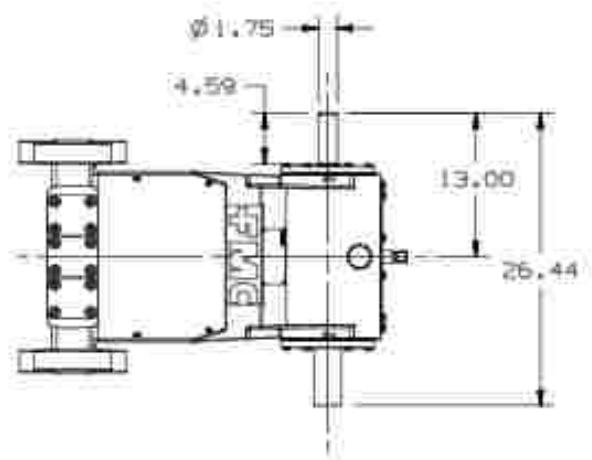

M12

Specifications

Design Standard	API 674, Third Edition
Configuration	Horizontal Triplex Plunger
Number of Plungers	3
Continuous Duty	62 BHP
Intermittent Duty	77 BHP
Stroke Length	3.0 inches
Frame Load Rating	6,000 lbs
Pump Weight (Average)	950 lbs
Intermittent Duty Speed Rating	500 RPM
Continuous Duty Speed Rating	400 RPM
Minimum Speed *	100 RPM
Mechanical Efficiency	90%
Lubrication System	Splash, Gravity Return
Crankcase Oil Capacity	3.25 Gallons
Lube Oil Type	SAE 30
Fluid Temperature Range	-20 to 350 °F
Valve Types	Disc Valves, Abrasion Resistant Valves

Slower RPM can be achieved with the addition of a pressurized lubrication system

Forged ISO drawing



Cast ISO drawing

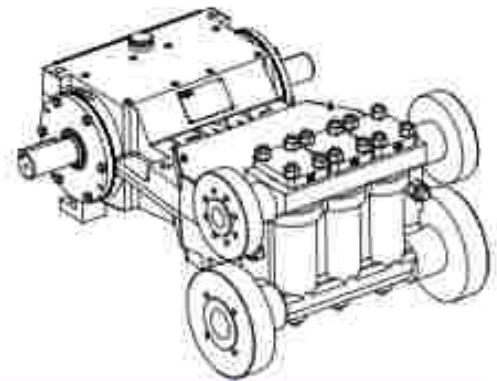

Performance data

Pump Model	Plunger Diameter (in)	Displacement (GAL/REV)	Maximum Pressure (PSI)	Pump Capacity (GPM) @ Input Speed (RPM)						
				100 RPM	200 RPM	300 RPM	350 RPM	400 RPM	450 RPM	500 RPM
M1207	0.875	0.0234	10,000	2.3	4.7	7.0	8.2	9.4	10.5	11.7
M1208	1.000	0.0306	7,600	3.1	6.1	9.2	10.7	12.2	13.8	15.3
M1210	1.250	0.0478	4,900	4.8	9.6	14.3	16.7	19.1	21.5	23.9
M1212	1.500	0.0688	3,400	6.9	13.8	20.6	24.1	27.5	31	34.4
M1214	1.750	0.0937	2,500	9.4	18.7	28.1	32.8	37.5	42.2	46.9
M1216	2.000	0.1224	1,900	12.2	24.5	36.7	42.8	49	55.1	61.2
M1218	2.250	0.1549	1,500	15.5	31	46.5	54.2	62	69.7	77.5
M1220	2.500	0.1912	1,250	19.1	38.2	57.4	66.9	76.5	86	95.6
M1222	2.750	0.2314	1,000	23.1	46.3	69.4	81	92.6	104	116
M1224	3.000	0.2754	850	27.5	55.1	82.6	96.4	110	124	138

M12

Standard connection sizes

Pump Model	Suction (in)	Discharge (in)
M1207-M1211	2.0	1.0
M1209-M1216	3.0	1.5
M1212-M1226	3.0	2.0

NPT connections available.

Fluid cylinder materials

Forged	Cast
A350 LF2 Carbon Steel	Ductile Iron
Hi-Strength Carbon Alloy Steel	Aluminum Bronze
2205 Duplex Stainless Steel	

Special materials available on request

M12 NPSHr values Disc Valves with 2-springs

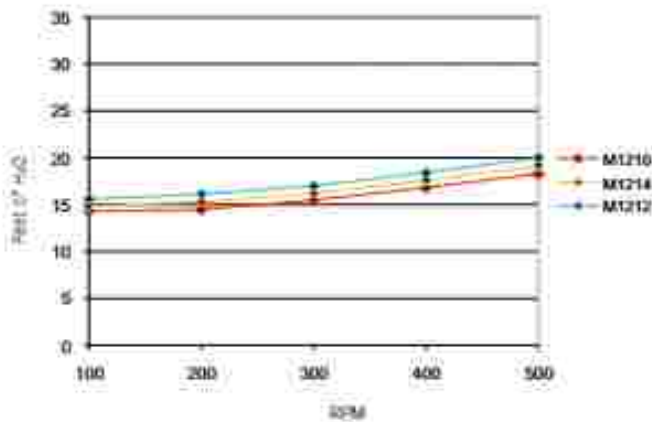

M12 NPSHr values Disc Valves with 2-springs

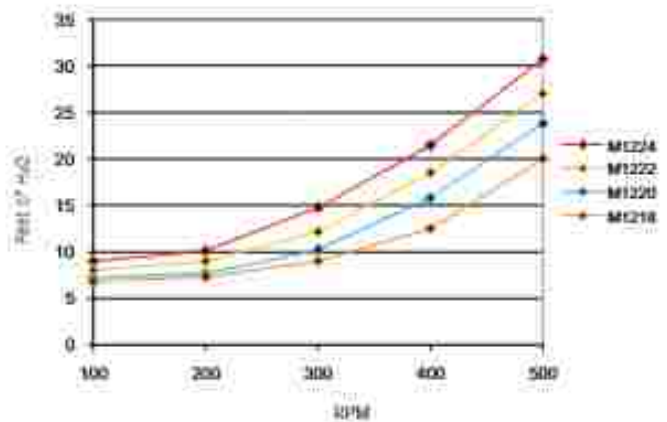

M12 NPSHr values Disc Valves with 1-spring

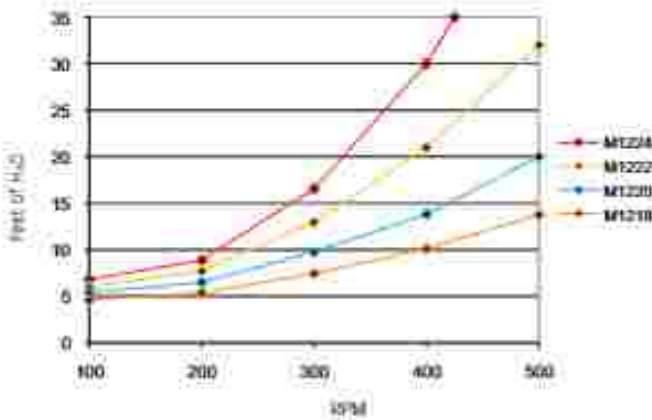

M12 NPSHr values AR Valves with 1-spring

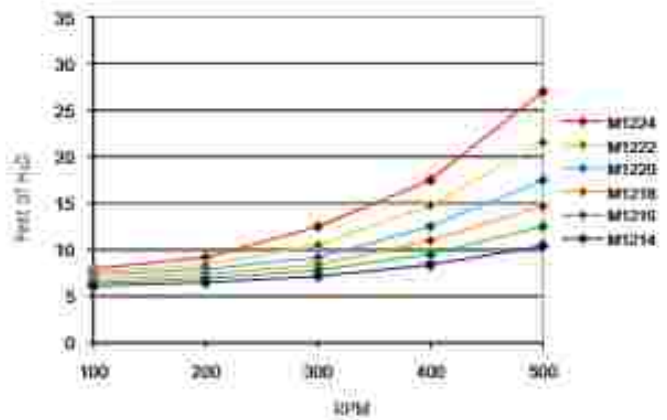

M12

Forged pump engineering dimensional outline

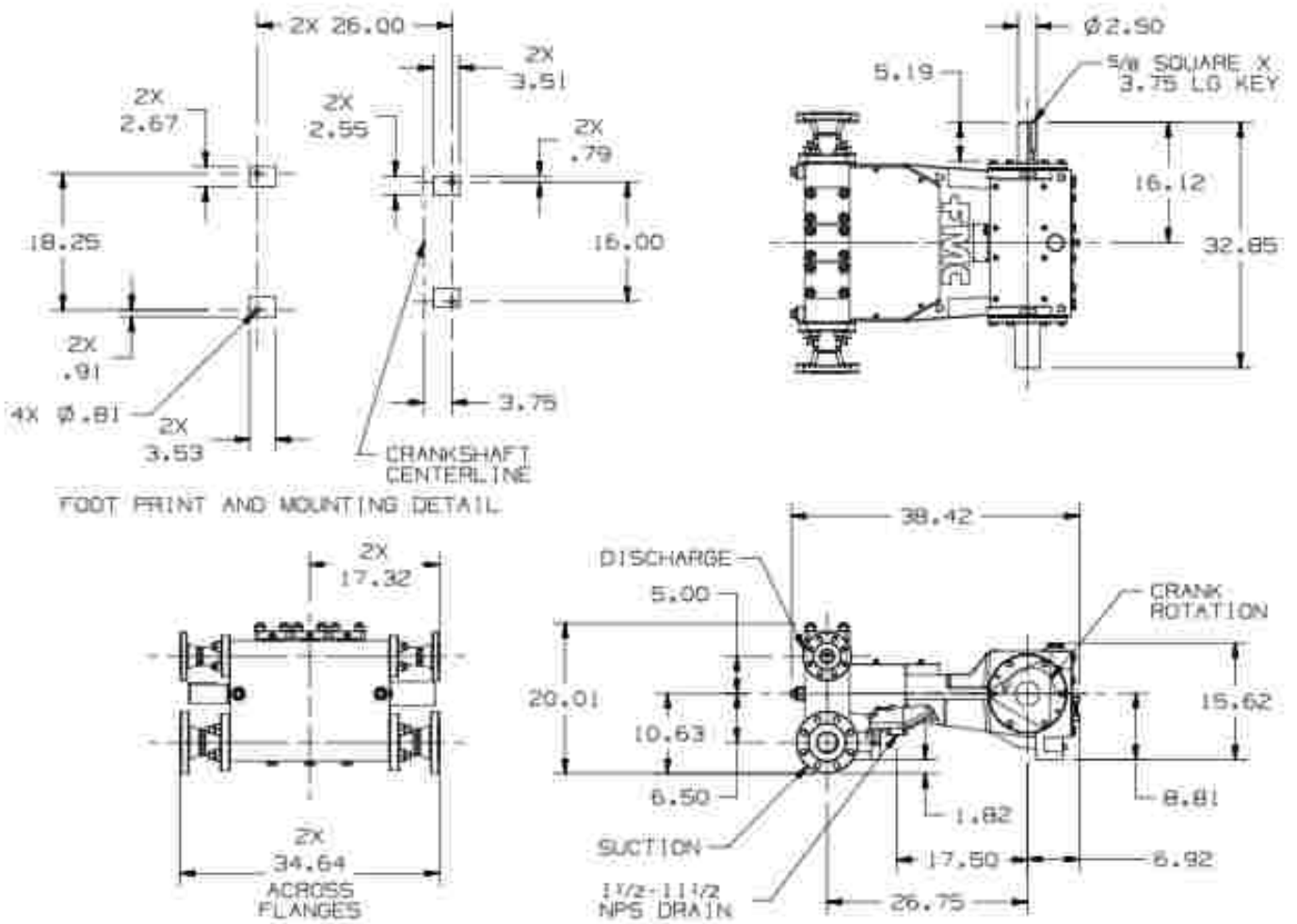

M12

Cast pump engineering dimensional outline

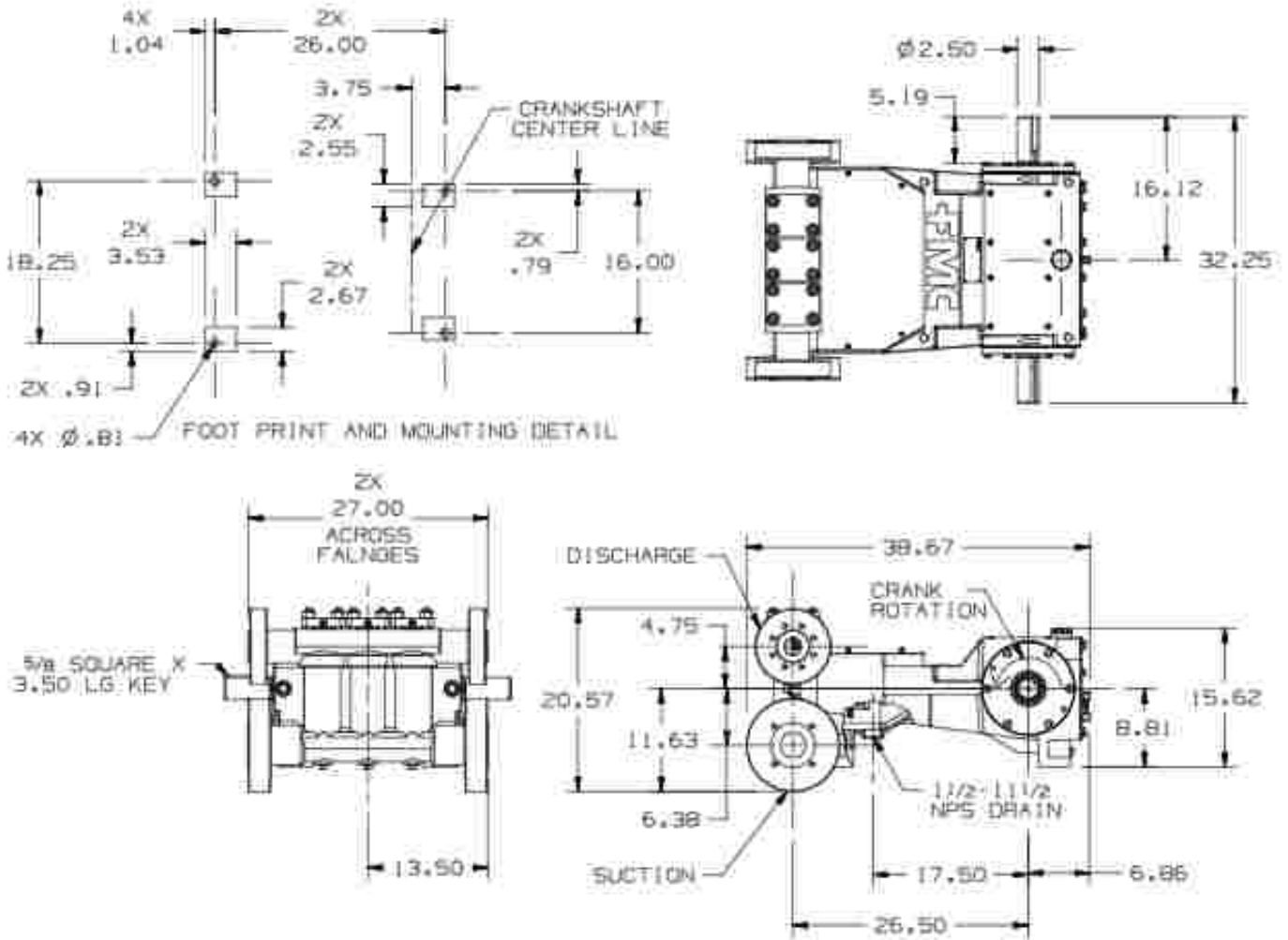

M13

Specifications

Design Standard	API-674, Third Edition
Configuration	Horizontal Triplex Plunger
Stroke Length	3.25 inches
Continuous Duty	84 BHP
Intermittent Duty	108 BHP
Frame Load Rating	7,900 lbs
Pump Weight (Average)	1,400 lbs
Intermittent Duty Speed Rating	500 RPM
Continuous Duty Speed Rating	387 RPM
Minimum Speed *	100 RPM
Mechanical Efficiency	90%
Lubrication System	Splash, Gravity Return
Crankcase Oil Capacity	4 Gallons
Lube Oil Type	SAE 30
Fluid Temperature Range	-20 to 350 °F

*Slower RPM can be achieved with the addition of a pressurized lubrication system

Forged ISO drawing

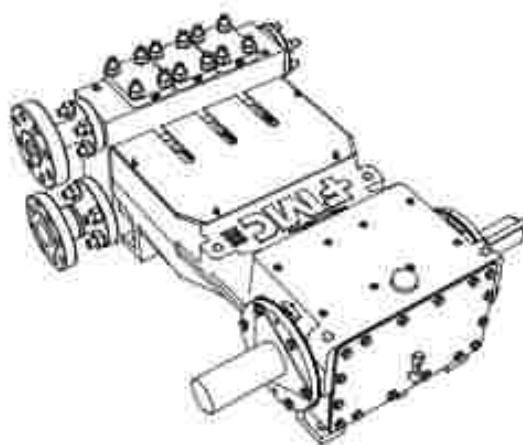

Performance data

Pump Model	Plunger Diameter (in)	Displacement (GAL/REV)	Maximum Pressure (PSI)	Pump Capacity (GPM) @ Input Speed (RPM)									
				100 RPM	150 RPM	200 RPM	250 RPM	300 RPM	350 RPM	387 RPM	400 RPM	450 RPM	500 RPM
M1308	1.000	0.0332	10,060	3.3	5.0	6.6	8.3	9.9	11.6	12.8	13.3	14.9	16.6
M1310	1.250	0.0518	6,450	5.2	7.8	10.4	13.0	15.5	18.1	20.0	20.7	23.3	25.9
M1312	1.500	0.0746	4,470	7.5	11.3	14.9	18.6	22.4	26.1	28.9	29.8	33.6	37.3
M1314	1.750	0.1015	3,280	10.2	15.3	20.3	25.4	30.5	35.5	39.3	40.6	45.7	50.8
M1316	2.000	0.1326	2,500	13.3	19.9	26.5	33.2	39.8	46.4	51.3	53.0	59.7	66.3
M1318	2.250	0.1678	2,000	16.8	25.2	33.6	42.0	50.4	58.7	65.0	67.1	75.5	83.9
M1320	2.500	0.2072	1,600	20.7	31.1	41.4	51.8	62.2	72.5	80.2	82.9	93.2	103.6
M1322	2.750	0.2507	1,330	25.1	37.6	50.1	62.7	75.2	87.7	97.0	100.3	112.8	125.4
M1324	3.000	0.2983	1,120	29.8	44.8	59.7	74.6	89.5	104.4	115.5	119.3	134.3	149.7
M1326	3.250	0.3501	950	35.0	52.5	70.0	87.5	105.0	122.5	135.5	140.0	157.6	175.1

M13

Forged pump engineering dimensional outline

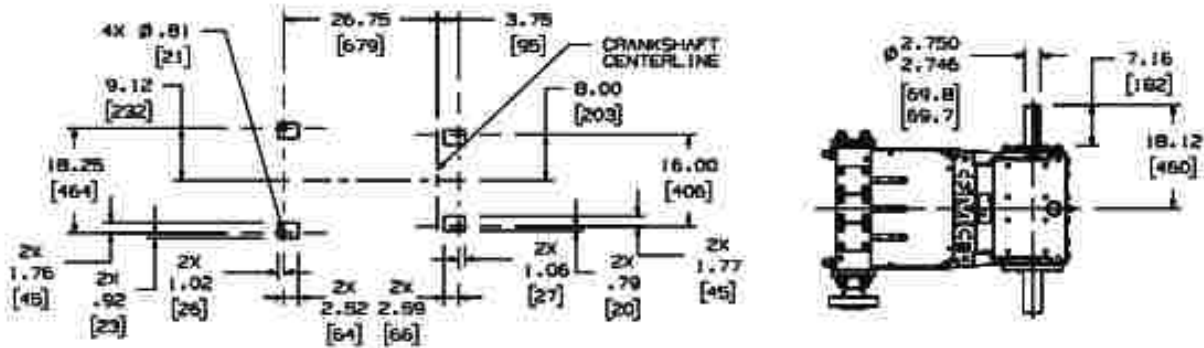

FOOT PRINT & MOUNTING DETAIL

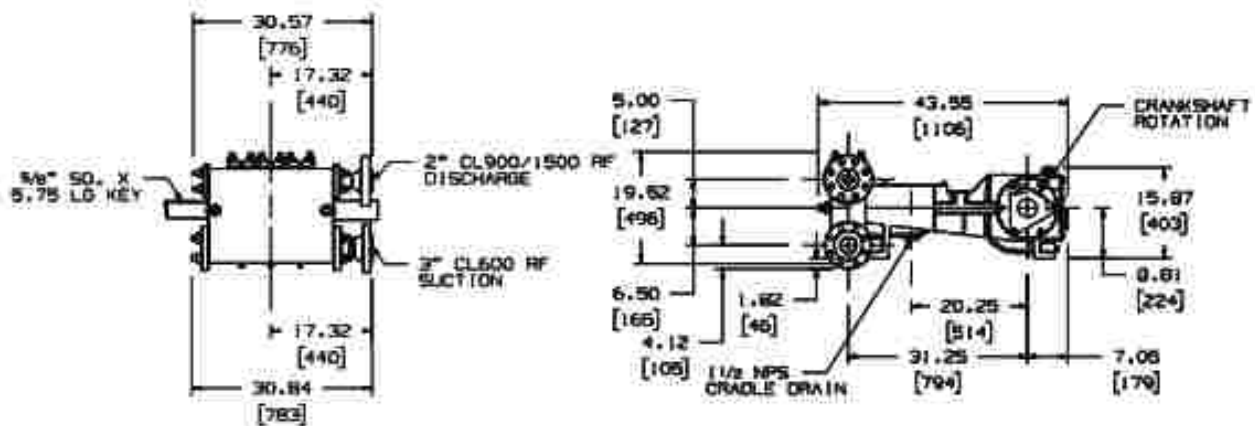

Standard connection sizes

Pump Model	Suction (in)	Discharge (in)
M1308-M1310	2.0	1.5
M1312-M1320	3.0	1.5
M1322-M1325	4.0	2.0

NPT connections available

Fluid cylinder materials

Forged	Cast
A350-LF2 Carbon Steel	Ductile Iron
Hi-Strength Carbon Alloy Steel	Aluminum Bronze
220% Duplex Stainless Steel	

Special materials available on request

M14

Specifications

Design Standard	API 674, Third Edition
Configuration	Horizontal Triplex Plunger
Number of Plungers	3
Continuous Duty	88 BHP
Intermittent Duty	104 BHP
Stroke Length	3.5 inches
Frame Load Rating	8,000 lbs
Pump Weight (Average)	1,800 lbs
Intermittent Duty Speed Rating	425 RPM
Continuous Duty Speed Rating	375 RPM
Minimum Speed *	100 RPM
Mechanical Efficiency	90%
Lubrication System	Splash, Gravity Return
Crankcase Oil Capacity	6 Gallons
Lube Oil Type	SAE 30
Fluid Temperature Range	-20 to 350 °F
Valve Types	Disc Valves, Abrasion Resistant Valves

Slower RPM can be achieved with the addition of a pressurized lubrication system

Forged ISO drawing

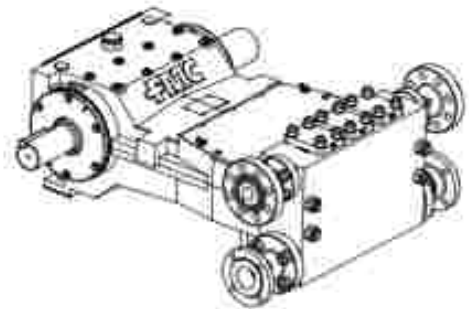

Cast ISO drawing

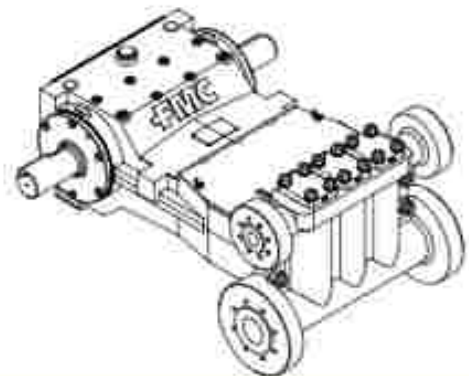

Performance data

Pump Model	Plunger Diameter (in)	Displacement (LAL/REV)	Maximum Pressure (PSI)	Pump Capacity (GPM) @ Input Speed (RPM)						
				100 RPM	200 RPM	300 RPM	350 RPM	375 RPM	400 RPM	425 RPM
M1408	1.000	0.0357	10,000	3.6	7.1	10.7	12.5	13.4	14.3	15.2
M1410	1.250	0.0658	6,500	5.6	11.2	16.7	19.5	20.9	22.3	23.7
M1412	1.500	0.0803	4,500	8.0	16.1	24.1	28.1	30.1	32.1	34.1
M1414	1.750	0.1093	3,300	10.9	21.9	32.8	38.3	41	43.7	46.5
M1416	2.000	0.1428	2,500	14.3	28.6	42.8	50.0	53.6	57.1	60.7
M1418	2.250	0.1807	2,000	18.1	36.1	54.2	63.2	67.8	72.3	76.8
M1420	2.500	0.2231	1,600	22.3	44.6	66.9	78.1	83.7	89.2	94.8
M1422	2.750	0.2700	1,350	27	54	81	95	101	108	115
M1424	3.000	0.3213	1,150	32.1	64.3	96.4	112	120	129	137
M1426	3.250	0.3771	1,000	37.7	75.4	113	132	141	151	160
M1428	3.500	0.4373	825	43.7	87.5	131	153	164	175	186
M1430	3.750	0.5020	725	50.2	100	151	176	188	201	213
M1432	4.000	0.5711	650	57	114	171	200	214	228	243

M14

Standard connection sizes

Pump Model	Suction (in)	Discharge (in)
M1408-M1420	3.0	2.0
M1418-M1432	4.0	2.0
M1428-M1432	4.0	3.0

NPT connections available.

Fluid cylinder materials

Forged	Cast
A350 LF2 Carbon Steel	Ductile Iron
Hi-Strength Carbon Alloy Steel	
220S Duplex Stainless Steel	

Special materials available on request

M14 NPSHr values

AR Valves with 1-spring

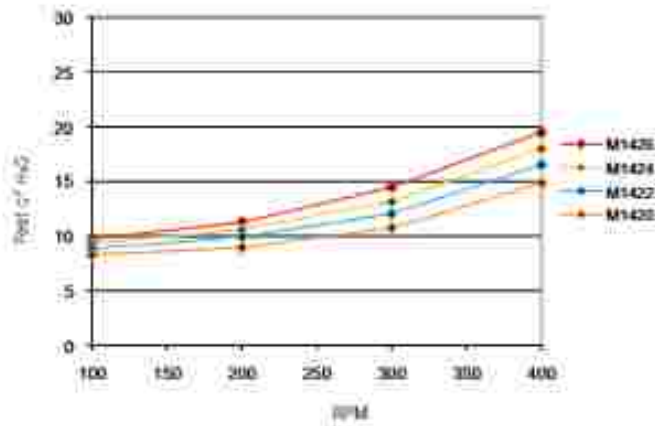

M14

Forged pump engineering dimensional outline

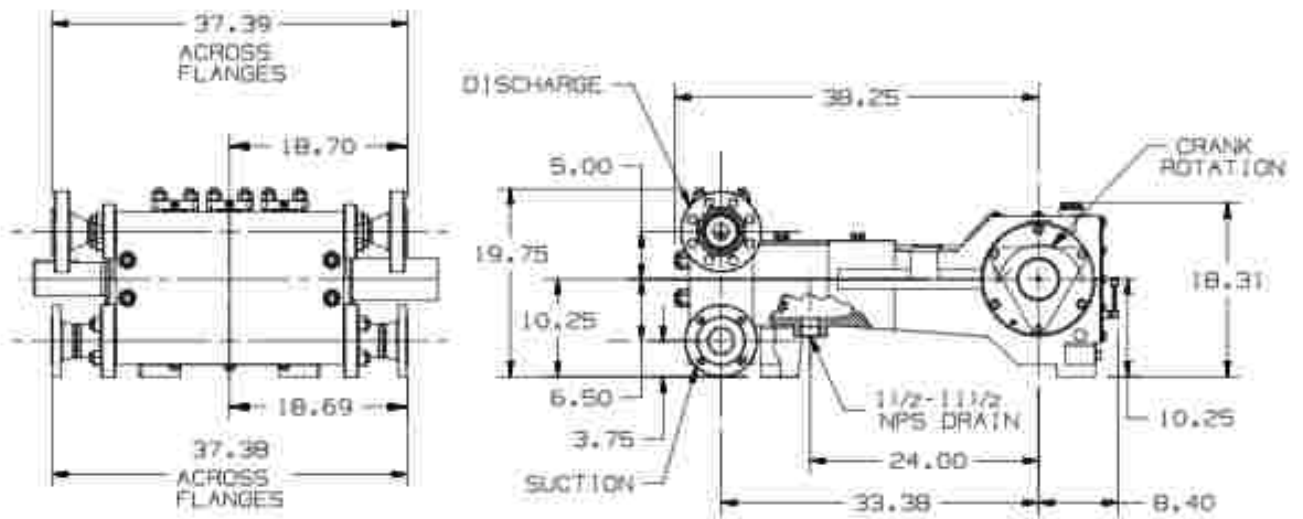
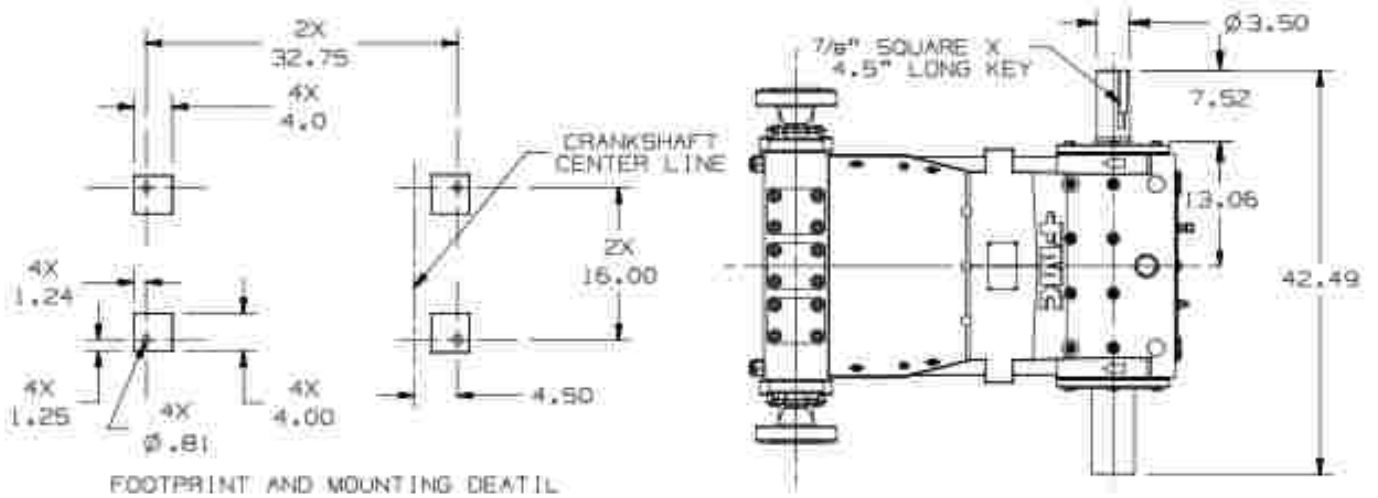

M14

Cast pump engineering dimensional outline

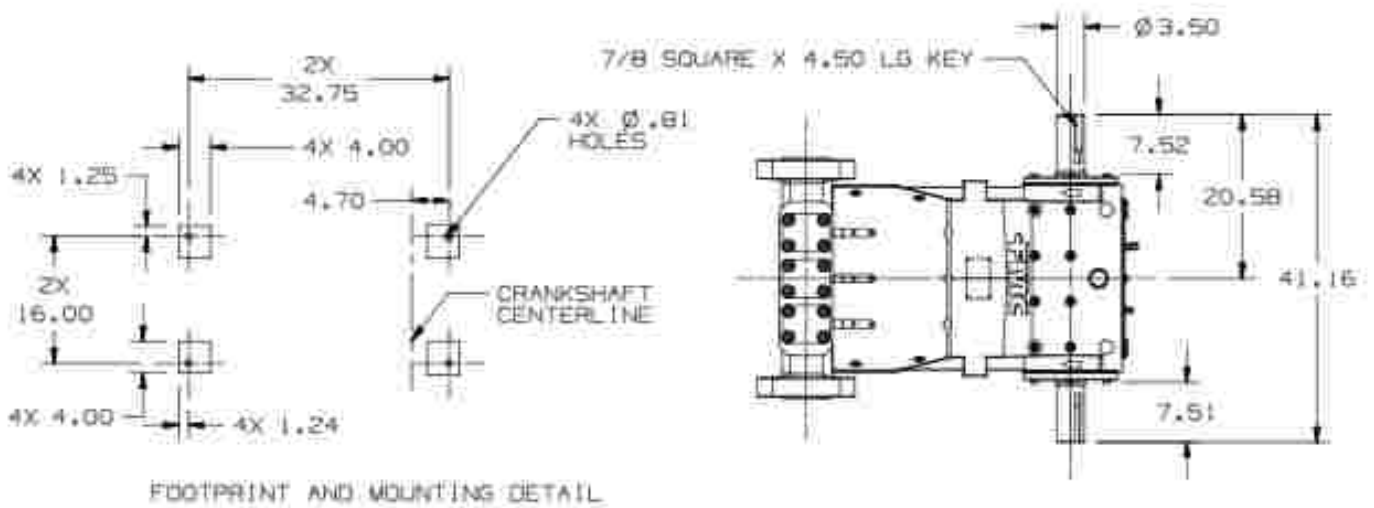

FOOTPRINT AND MOUNTING DETAIL

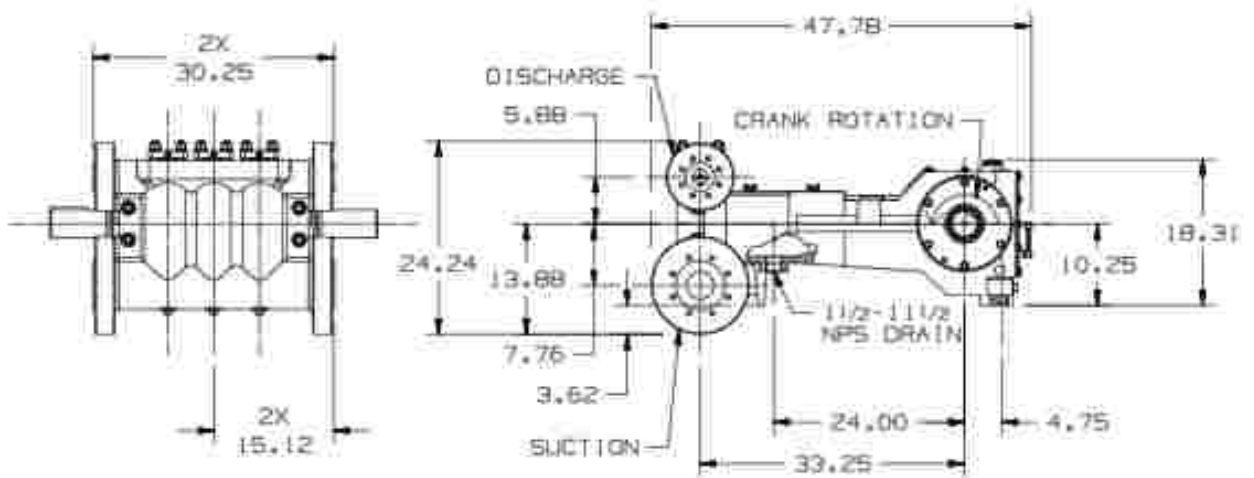

M16

Specifications

Design Standard	API 674, Third Edition
Configuration	Horizontal Triplex Plunger
Number of Plungers	3
Continuous Duty	117 BHP
Intermittent Duty	142 BHP
Stroke Length	4.0 inches
Frame Load Rating	9,800 lbs
Pump Weight (Average)	2,400 lbs
Intermittent Duty Speed Rating	425 RPM
Continuous Duty Speed Rating	350 RPM
Minimum Speed *	100 RPM
Mechanical Efficiency	90%
Lubrication System	Splash, Gravity Return
Crankcase Oil Capacity	9 US gallons
Lube Oil Type	SAE 30
Fluid Temperature Range	-20 to 350 °F
Valve Types	Disc Valves, Abrasion Resistant Valves

Slower RPM can be achieved with the addition of a pressurized lubrication system

Performance data

Pump Model	Plunger Diameter (in)	Displacement (GAL/REV)	Maximum Pressure (PSI)	Pump Capacity (GPM) @ Input Speed (RPM)					
				100 RPM	200 RPM	300 RPM	350 RPM	400 RPM	425 RPM
M1609	1.125	0.0516	10,000	5.2	10.3	15.5	18.1	20.6	21.9
M1610	1.250	0.0637	8,000	6.4	12.7	19.1	22.3	25.5	27.1
M1612	1.500	0.0918	5,500	9.2	18.4	27.5	32.1	36.7	39.0
M1614	1.750	0.1249	4,065	12.5	25.0	37.5	43.7	50.0	53.1
M1616	2.000	0.1632	3,115	16.3	32.6	49.0	57.1	65.3	69.4
M1618	2.250	0.2065	2,460	20.7	41.3	62.0	72.3	82.6	87.8
M1620	2.500	0.2550	1,990	25.5	51.0	76.5	89.3	102	108
M1622	2.750	0.3085	1,650	30.9	61.7	92.6	108	123	131
M1624	3.000	0.3672	1,385	36.7	73.4	110	128	147	156
M1626	3.250	0.4309	1,180	43.1	86.2	129	151	172	183
M1628	3.500	0.4998	1,015	50.0	100	150	175	200	212
M1630	3.750	0.5737	885	57.4	115	172	201	229	244
M1632	4.000	0.6528	775	65.3	131	196	228	261	277
M1634	4.250	0.7369	690	73.7	147	221	258	295	313
M1636	4.500	0.8262	570	82.6	165	248	289	330	351

Forged ISO drawing

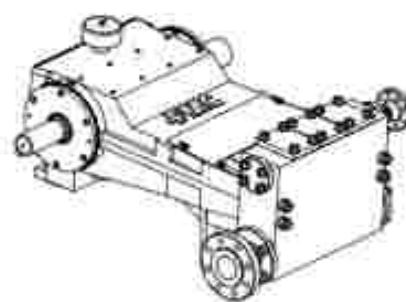

Cast ISO drawing

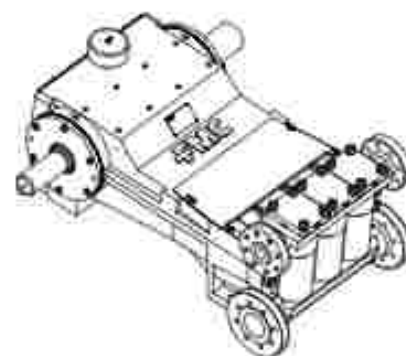

M16

Standard connection sizes

Pump Model	Suction (in)	Discharge (in)
M1609-M1618	3.0	1.5
M1618-M1636	4.0	2.0
M1628-M1636	6.0	3.0

NPT connections available.

Fluid cylinder materials

Forged	Cast
A350-LF2 Carbon Steel	Ductile Iron
Hi-Strength Carbon Alloy Steel	Aluminum Bronze
2205 Duplex Stainless Steel	

Special materials available on request

M16 NPSHr values Disc Valves with 2-springs

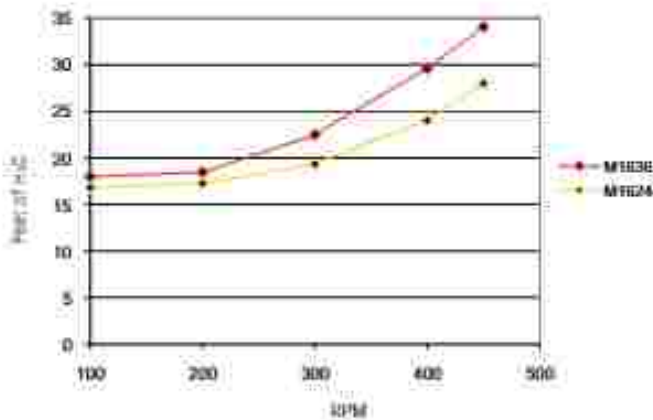

M16 NPSHr values AR Valves with 1-spring

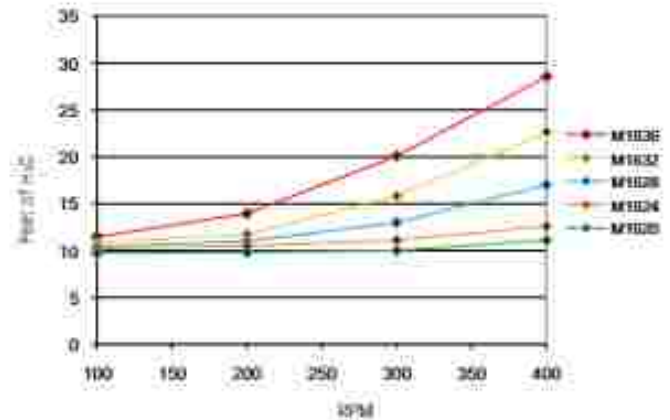

M16 NPSHr values Disc Valves with 1-spring

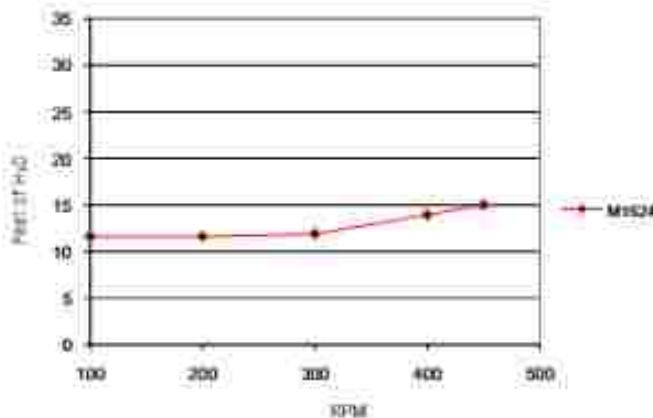

M16

Forged pump engineering dimensional outline

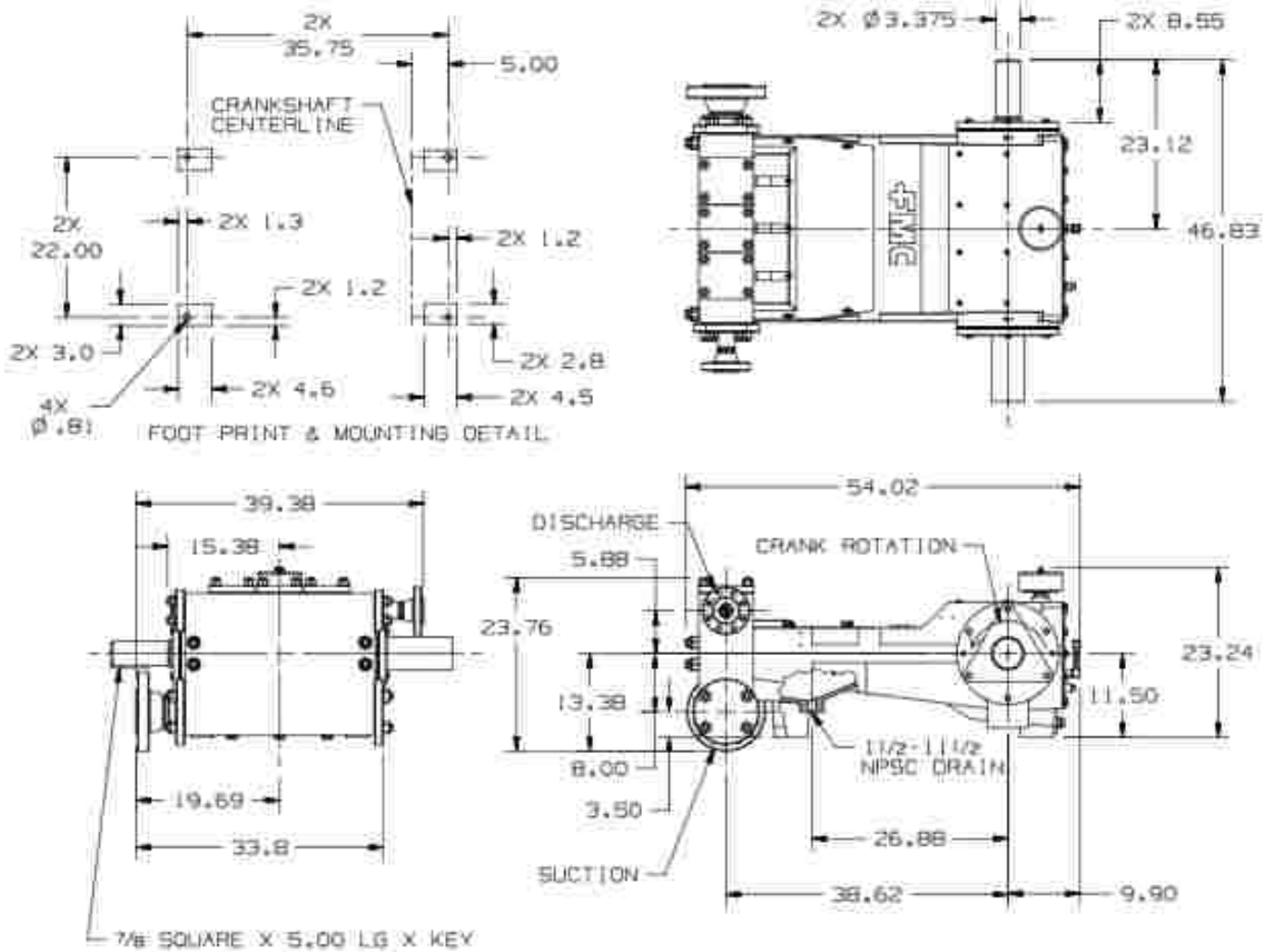

M16

Cast pump engineering dimensional outline

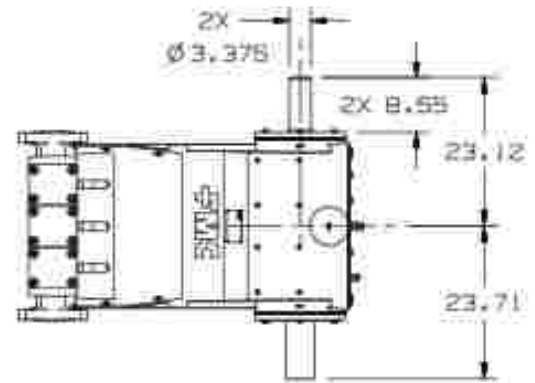
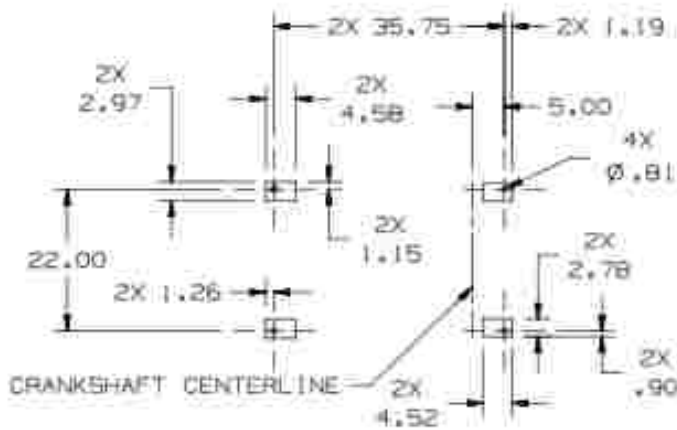

FOOT PRINT & MOUNTING DETAIL

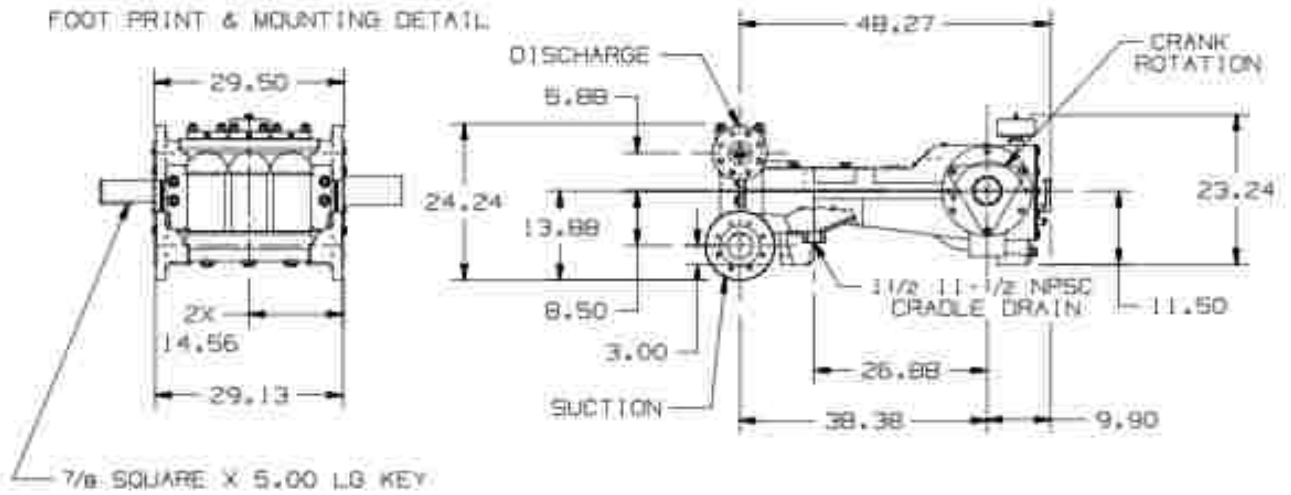

M18

Specifications

Design Standard	API 674, Third Edition
Configuration	Horizontal Triplex Plunger
Number of Plungers	3
Continuous Duty	150 BHP
Intermittent Duty	190 BHP
Stroke Length	4.5 inches
Frame Load Rating	12,000 lbs
Pump Weight (Average)	2,400 lbs
Intermittent Duty Speed Rating	400 RPM
Continuous Duty Speed Rating	330 RPM
Minimum Speed	100 RPM
Mechanical Efficiency *	90%
Lubrication System	Splash, Gravity Return
Crankcase Oil Capacity	9 Gallons
Lube Oil Type	SAE 30
Fluid Temperature Range	-20 to 350 °F
Valve Types	Disc Valves, Abrasion Resistant Valves

Slower RPM can be achieved with the addition of a pressurized lubrication system

Performance data

Pump Model	Plunger Diameter (in)	Displacement (GAL/REV)	Maximum Pressure (PSI)	Pump Capacity (GPM) @ Input Speed (RPM)					
				100 RPM	200 RPM	300 RPM	330 RPM	350 RPM	400 RPM
M1810	1.250	0.0717	9,800	7.2	14	22	24	25	29
M1812	1.500	0.1033	6,800	10	21	31	34	36	41
M1814	1.750	0.1406	5,000	14	28	42	46	49	56
M1816	2.000	0.1836	3,800	18	37	55	61	64	73
M1818	2.250	0.2324	3,000	23	47	70	77	81	93
M1820	2.500	0.2869	2,400	29	57	86	95	100	115
M1822	2.750	0.3471	2,000	35	69	104	115	122	139
M1824	3.000	0.4131	1,700	41	83	124	136	145	165
M1826	3.250	0.4848	1,480	49	97	145	160	170	194
M1828	3.500	0.5623	1,200	56	113	169	186	197	225
M1830	3.750	0.6455	1,100	65	129	194	213	226	258
M1832	4.000	0.7344	1,000	73	147	220	242	257	294
M1834	4.250	0.8291	800	83	166	249	274	290	332
M1836	4.500	0.9295	750	93	186	279	307	325	372

Forged ISO drawing

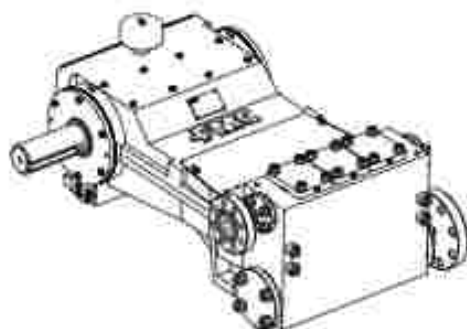

Cast ISO drawing

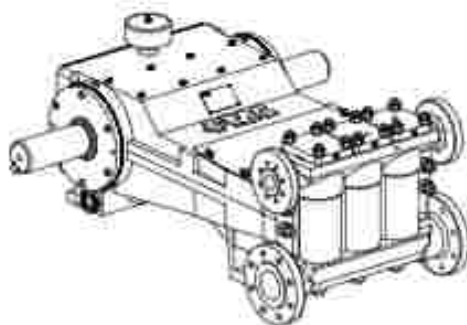

M18

Standard connection sizes

Pump Model	Suction (in)	Discharge (in)
M1810-M1816	3.0	1.5
M1818-M1826	4.0	2.0
M1828-M1836	6.0	3.0

NPT connections available.

Fluid cylinder materials

Forged	Cast
A350 LF2 Carbon Steel	Ductile Iron
Hi-Strength Carbon Alloy Steel	Aluminum Bronze
220S Duplex Stainless Steel	

Special materials available on request

M18 NPSHr values

Disc Valves with 2-springs

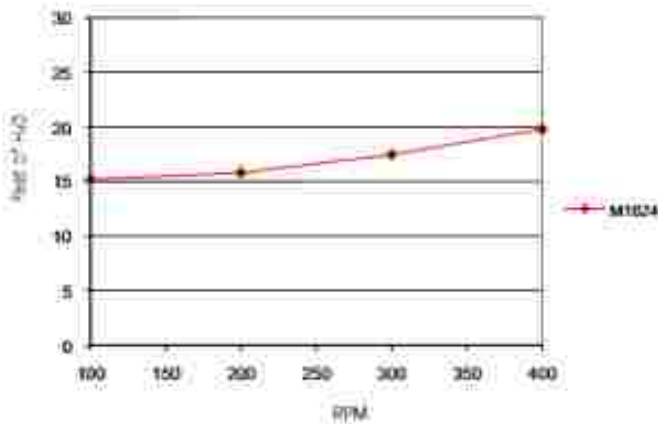

M18 NPSHr values

AR Valves with 1-spring

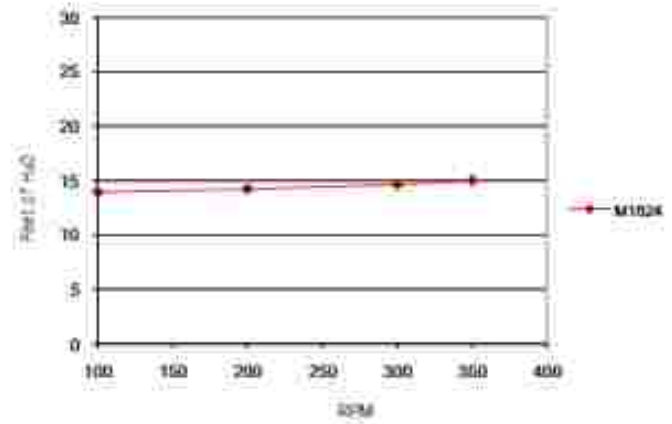

M18

Forged pump engineering dimensional outline

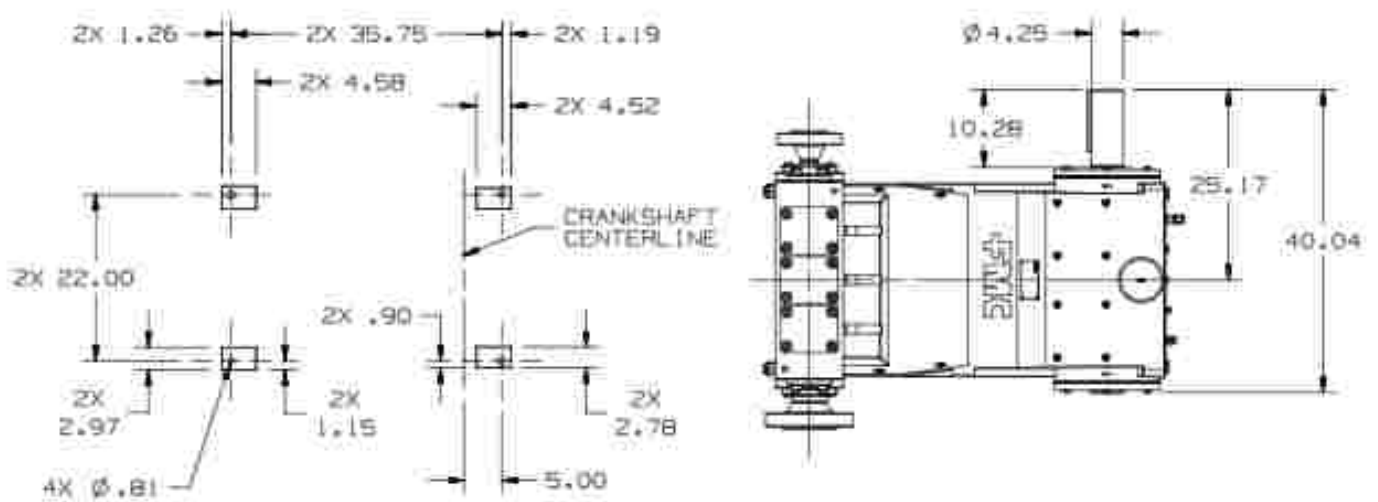

FOOT PRINT AND MOUNTING DETAIL

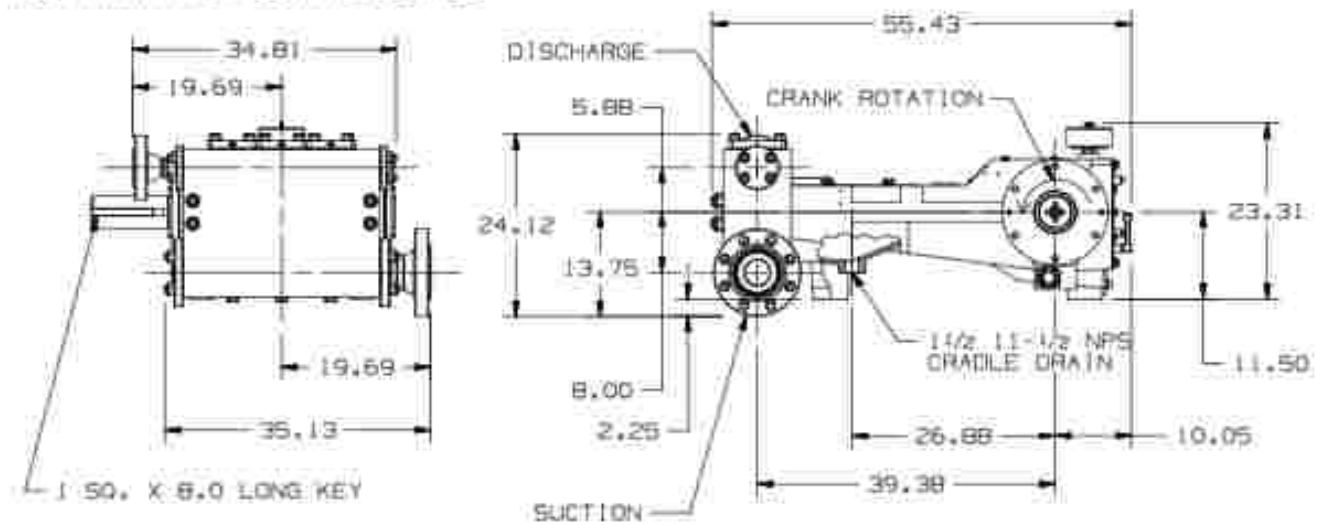

M18

Cast pump engineering dimensional outline

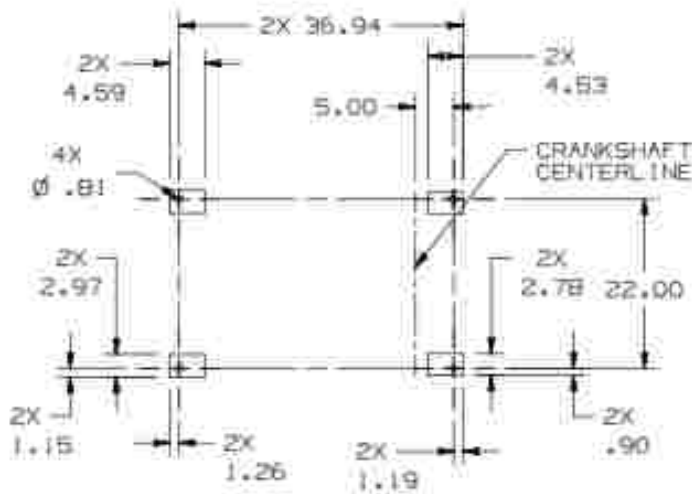

FOOT PRINT & MOUNTING DETAIL

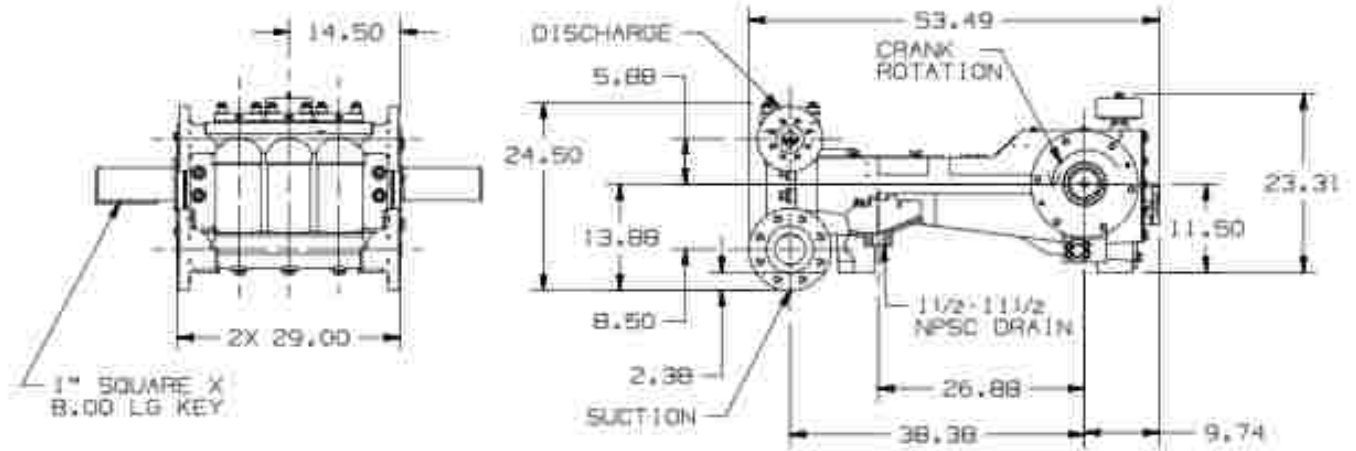
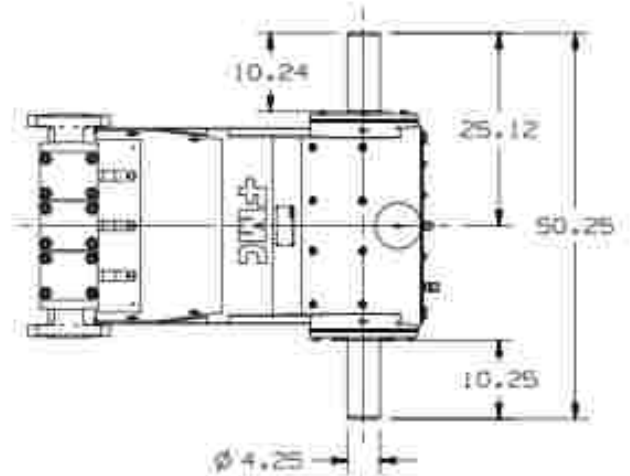

Q16

Specifications

Design Standard	API 674, Third Edition
Configuration	Horizontal Quintuplex Plunger
Number of Plungers	5
Continuous Duty	198 BHP
Intermittent Duty	240 BHP
Stroke Length	4.0 inches
Frame Load Rating	10,000 lbs
Pump Weight (Average)	4,500 lbs
Intermittent Duty Speed Rating	425 RPM
Continuous Duty Speed Rating	350 RPM
Minimum Speed *	100 RPM
Mechanical Efficiency	90%
Lubrication System	Splash, Gravity Return
Crankcase Oil Capacity	16 Gallons
Lube Oil Type	SAE 30
Fluid Temperature Range	-20 to 350 °F
Valve Types	Disc Valves, Abrasion Resistant Valves

*Slower RPM can be achieved with the addition of a pressurized lubrication system

Performance data

Pump Model	Plunger Diameter (in)	Displacement (GAL/REV)	Maximum Pressure (PSI)	Pump Capacity (GPM) @ Input Speed (RPM)					
				100 RPM	200 RPM	300 RPM	350 RPM	400 RPM	425 RPM
Q1609	1.125	0.0861	10,000	8.6	17	26	30	34	37
Q1610	1.250	0.1062	8,150	11	21	32	37	43	45
Q1612	1.500	0.1530	5,650	15	31	46	54	61	65
Q1614	1.750	0.2082	4,160	21	42	63	73	83	89
Q1616	2.000	0.2720	3,190	27	54	82	95	109	116
Q1618	2.250	0.3442	2,520	34	69	103	121	138	146
Q1620	2.500	0.4250	2,040	43	85	128	149	170	181
Q1622	2.750	0.5142	1,690	51	103	154	180	206	219
Q1624	3.000	0.6120	1,420	61	122	184	214	245	260
Q1626	3.250	0.7182	1,210	72	144	216	251	287	305
Q1628	3.500	0.8330	1,040	83	167	250	292	333	354
Q1630	3.750	0.9562	910	96	191	287	335	383	406
Q1632	4.000	1.0880	800	109	218	326	381	435	462
Q1634	4.250	1.2282	710	123	246	369	430	491	522
Q1636	4.500	1.3770	630	138	275	413	482	551	585

Forged ISO drawing

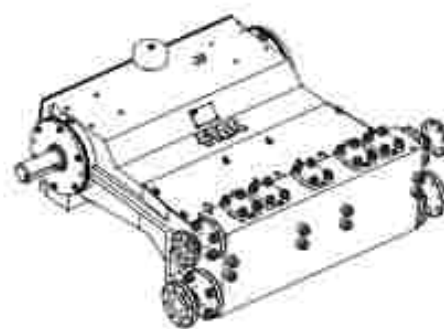

Cast ISO drawing

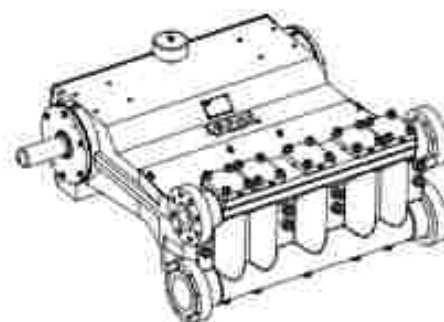

Q16

Standard connection sizes

Pump Model	Suction (in)	Discharge (in)
Q1609-Q1618	4.0	2.0
Q1620-Q1628	6.0	3.0
Q1628-Q1636	8.0	4.0

NPT connections available.

Fluid cylinder materials

Forged	Cast
A350 LF2 Carbon Steel	Ductile Iron
Hi-Strength Carbon Alloy Steel	Aluminium Bronze
2205 Duplex Stainless Steel	

Special materials available on request.

Q16 NPSHr values

Disc Valves with 2-springs

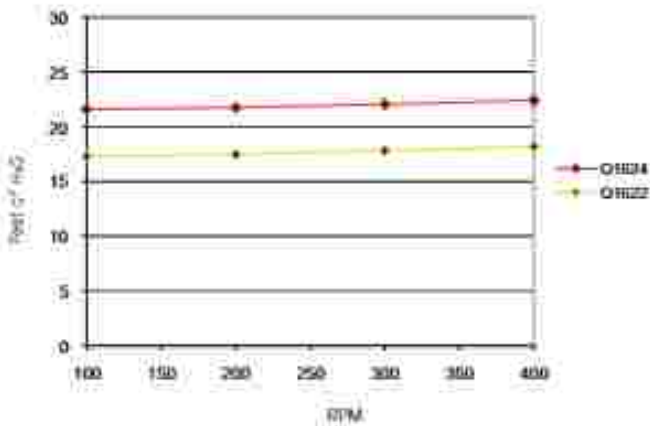

Q16

Forged pump engineering dimensional outline

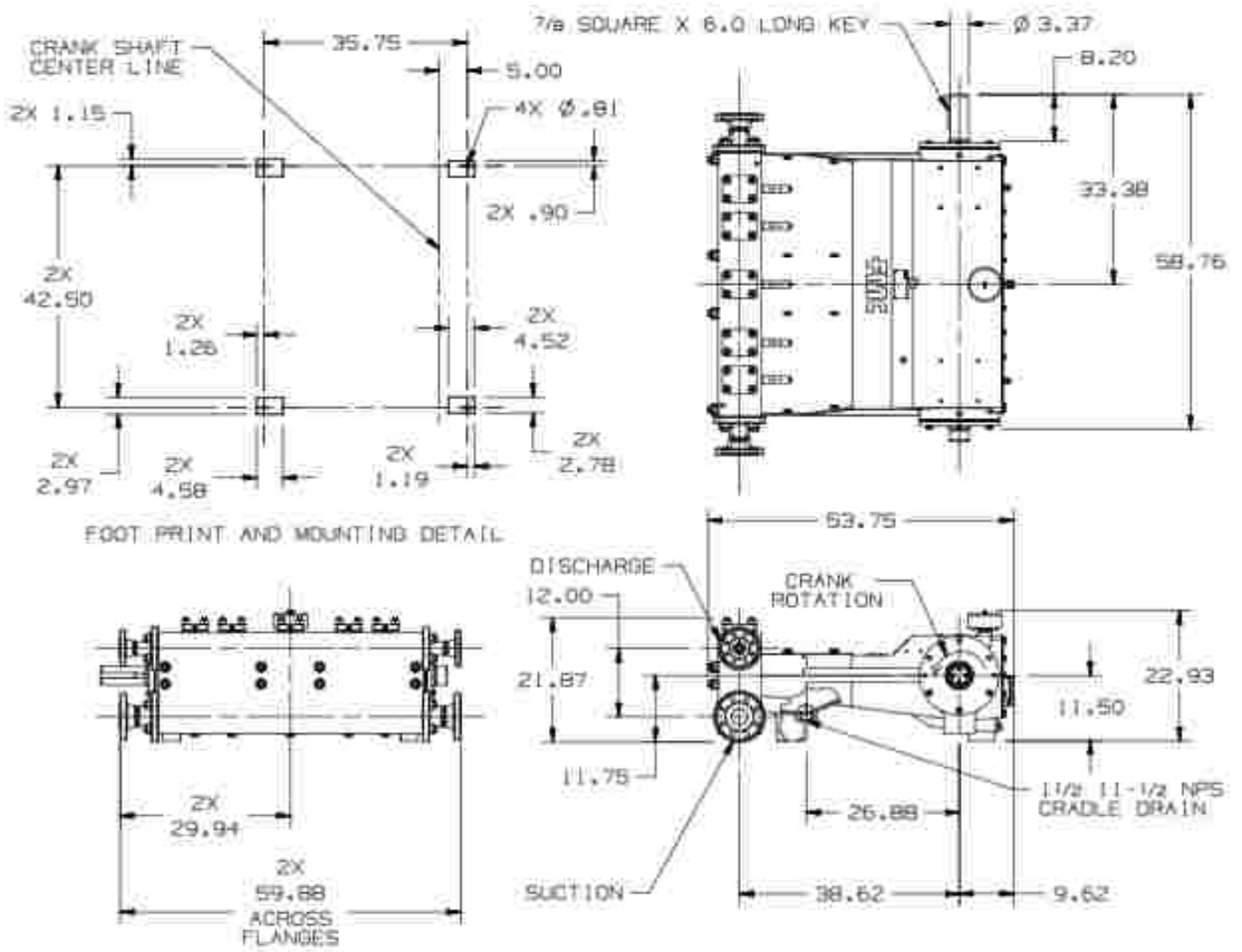

Q16

Cast pump engineering dimensional outline

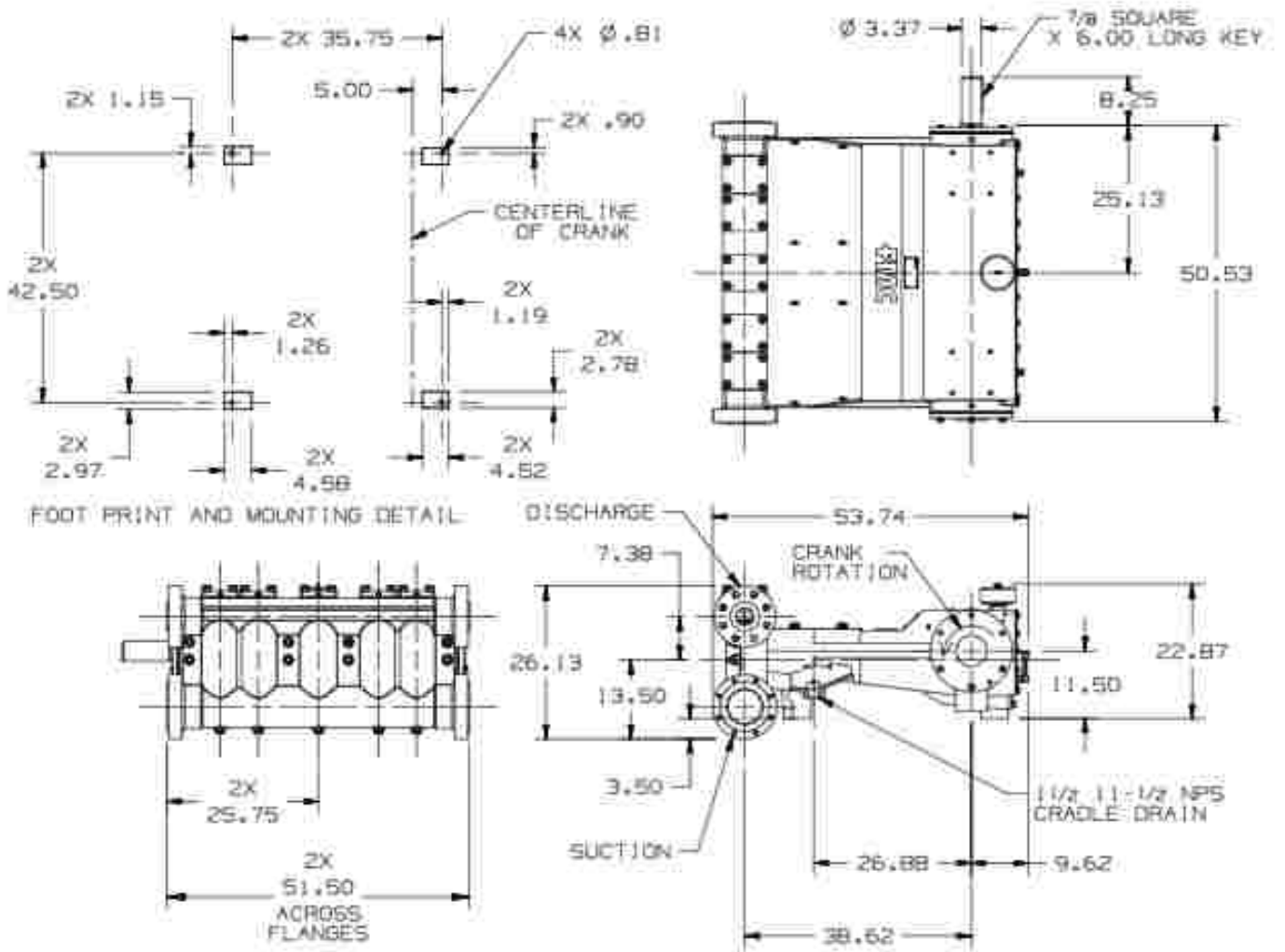

Q18

Specifications

Design Standard	API 674, Third Edition
Configuration	Horizontal Quintuplex Plunger
Number of Plungers	5
Continuous Duty	265 BHP
Intermittent Duty	325 BHP
Stroke Length	4.5 inches
Frame Load Rating	12,500 lbs
Pump Weight (Average)	4,500 lbs
Intermittent Duty Speed Rating	400 RPM
Continuous Duty Speed Rating	330 RPM
Minimum Speed *	100 RPM
Mechanical Efficiency	90%
Lubrication System	Splash, Gravity Return
Crankcase Oil Capacity	16 Gallons
Lube Oil Type	SAE 30
Fluid Temperature Range	-20 to 350 °F
Valve Types	Disc Valves, Abrasion Resistant Valves

*Slower RPM can be achieved with the addition of a pressurized lubrication system

Forged ISO drawing

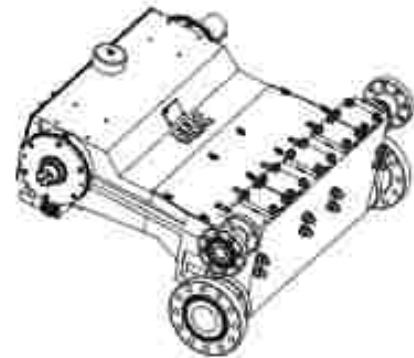

Cast ISO drawing

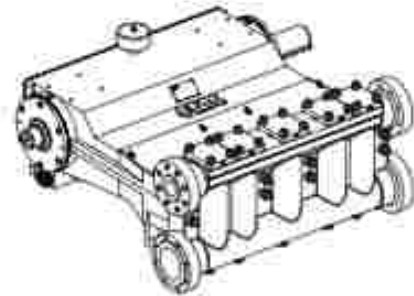

Performance data

Pump Model	Plunger Diameter (in)	Displacement (GAL/REV)	Maximum Pressure (PSI)	Pump Capacity (GPM) @ Input Speed (RPM)					
				100 RPM	200 RPM	300 RPM	330 RPM	350 RPM	400 RPM
Q1811	1.375	0.1446	8,400	15	29	44	48	51	58
Q1812	1.500	0.1721	7,100	17	34	52	57	60	69
Q1814	1.750	0.2343	5,200	23	47	70	77	82	94
Q1816	2.000	0.3060	4,000	31	61	92	101	107	122
Q1818	2.250	0.3873	3,100	39	78	116	128	136	155
Q1820	2.500	0.4781	2,500	48	96	143	158	167	191
Q1822	2.750	0.5785	2,100	58	116	174	191	202	231
Q1824	3.000	0.6885	1,800	69	138	207	227	241	275
Q1826	3.250	0.8080	1,500	81	162	242	267	283	323
Q1828	3.500	0.9371	1,300	94	187	281	309	328	375
Q1830	3.750	1.0758	1,100	108	215	323	355	377	430
Q1832	4.000	1.2240	1,000	122	245	367	404	428	490
Q1834	4.250	1.3818	900	138	276	415	456	484	553
Q1836	4.500	1.5491	800	155	310	465	511	542	620

Q18

Standard connection sizes

Pump Model	Suction (in)	Discharge (in)
Q1811-Q1816	4.0	2.0
Q1820-Q1826	6.0	3.0
Q1830-Q1836	8.0	4.0

NPT connections available.

Fluid cylinder materials

Forged	Cast
A350 LF2 Carbon Steel	Ductile Iron
Hi-Strength Carbon Alloy Steel	Aluminium Bronze
2205 Duplex Stainless Steel	

Special materials available on request

Q18 NPSHr values

Disc Valves with 2-springs

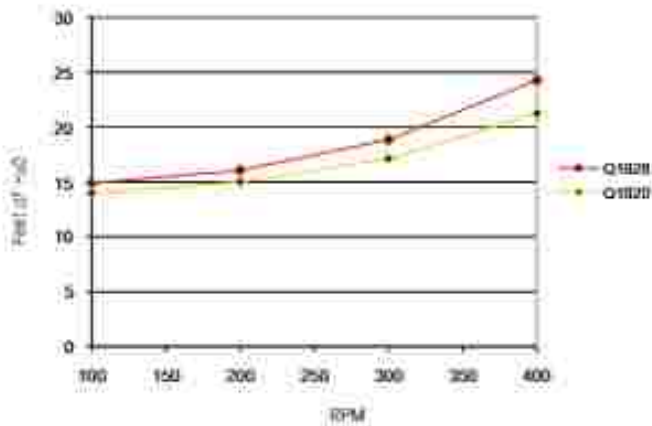

Q18 NPSHr values

AR Valves with 1-springs

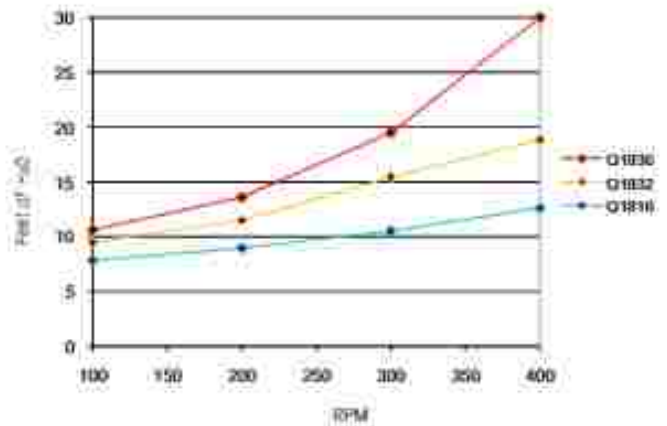

Q18

Forged pump engineering dimensional outline

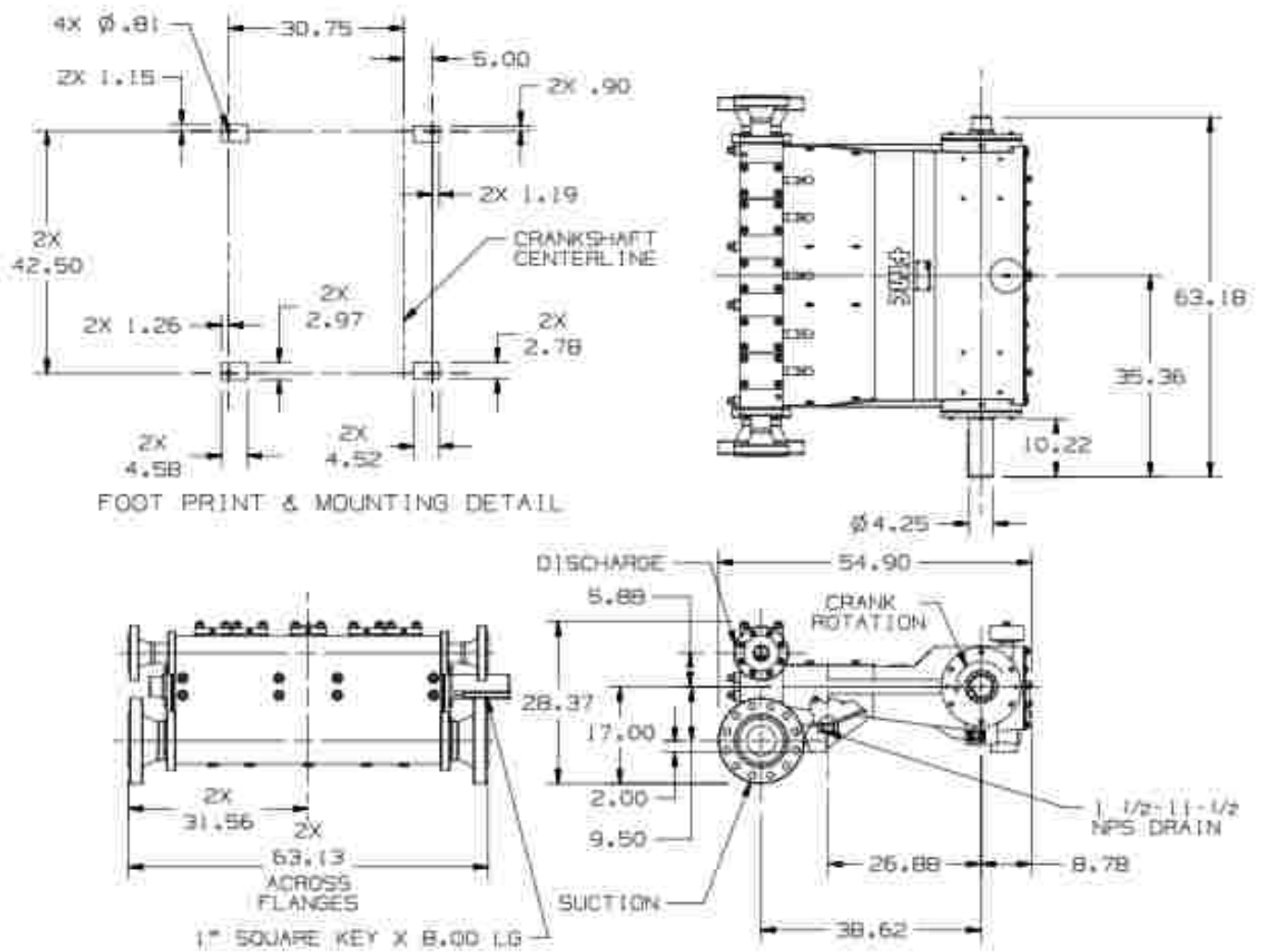

Q18

Cast pump engineering dimensional outline

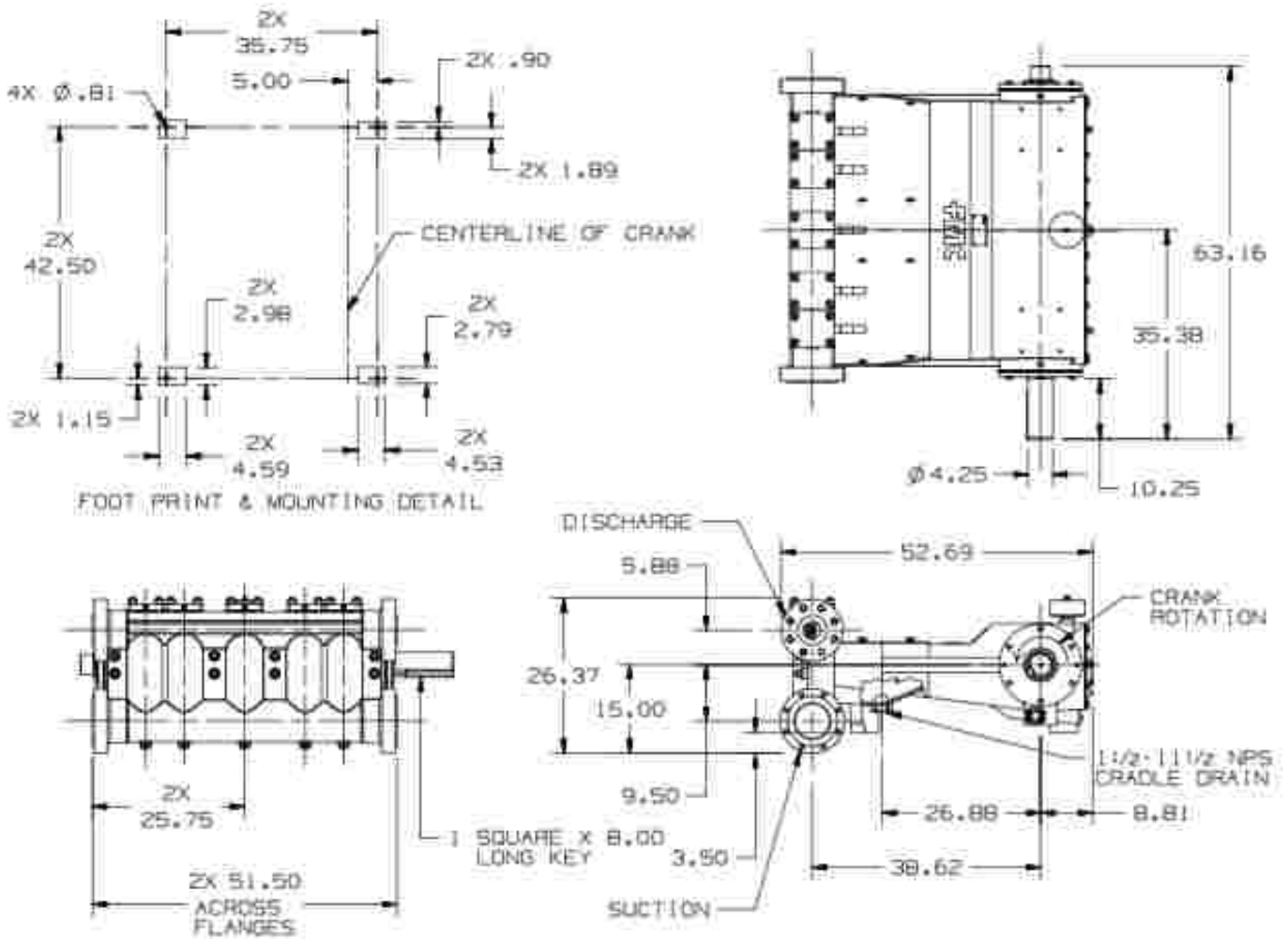

M28

Specifications

Design Standard	API 674, Third Edition
Configuration	Horizontal Triplex Plunger
Number of Plungers	3
Continuous Duty	350 BHP
Intermittent Duty	440 BHP
Stroke Length	7.0 inches
Frame Load Rating	25,000 lbs
Pump Weight (Average)	5,500 lbs
Intermittent Duty Speed Rating	300 RPM
Continuous Duty Speed Rating	240 RPM
Minimum Speed *	100 RPM
Mechanical Efficiency	90%
Lubrication System	Splash, Gravity Return
Crankcase Oil Capacity	14.25 Gallons
Lube Oil Type	SAE 30
Fluid Temperature Range	-20 to 350 °F
Valve Types	Disc Valves, Abrasion Resistant Valves

Forged ISO drawing

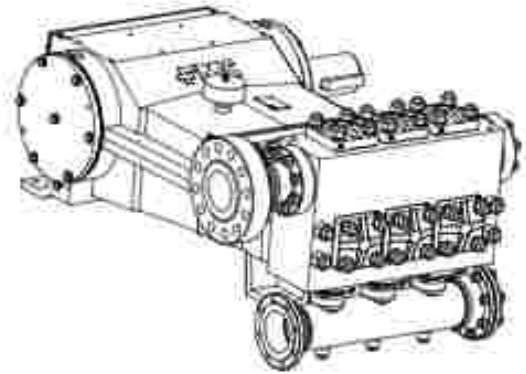

Slower RPM can be achieved with the addition of a pressurized lubrication system

M28 NPSHr values

Disc Valves with 2-springs

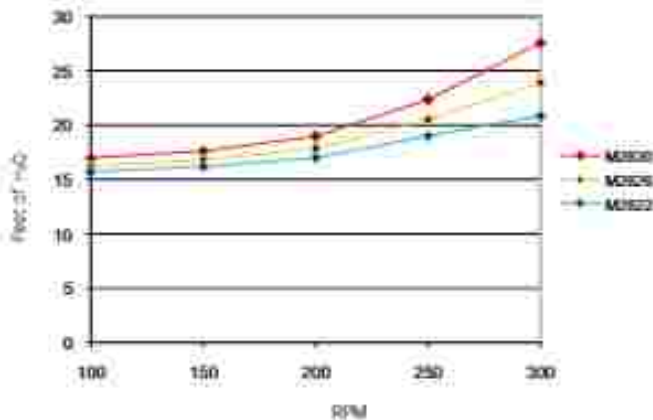

Bolt-on gearbox ratios available

6.17 : 1
7.44 : 1
9.55 : 1

M28

Performance data

Pump Model	Plunger Diameter (in)	Displacement (GAL/REV)	Maximum Pressure (PSI)	Pump Capacity (GPM @ Input Speed (RPM))					
				100 RPM	150 RPM	200 RPM	240 RPM	250 RPM	300 RPM
M2812	1.500	0.1606	10,000	16	24	32	39	40	48
M2814	1.750	0.2187	10,000	22	33	44	53	55	66
M2816	2.000	0.2856	7,960	29	43	57	69	71	86
M2818	2.250	0.3615	6,300	36	54	72	87	90	109
M2820	2.500	0.4462	5,100	45	67	89	107	112	134
M2822	2.750	0.5400	4,200	54	81	108	130	135	162
M2824	3.000	0.6426	3,540	64	96	129	154	161	193
M2826	3.250	0.7542	3,015	75	113	151	181	189	226
M2828	3.500	0.8746	2,600	88	131	175	210	219	262
M2830	3.750	1.0041	2,260	100	151	201	241	251	301
M2832	4.000	1.1424	1,990	114	171	229	274	286	343
M2834	4.250	1.2897	1,760	129	194	258	310	322	387
M2836	4.500	1.4458	1,570	145	217	289	347	361	434
M2838	4.750	1.6110	1,400	161	242	322	387	403	483
M2840	5.000	1.7580	1,275	176	264	352	422	440	527
M2842	5.250	1.9680	1,155	197	295	394	472	492	590
M2844	5.500	2.1598	1,050	216	324	432	518	540	648
M2846	5.750	2.3677	960	236	354	472	567	590	708
M2848	6.000	2.5704	880	257	386	514	617	643	771
M2850	6.250	2.7891	815	279	418	558	669	697	837

Standard connection sizes

Pump Model	Suction (in)	Discharge (in)
M2812-M2820	4.0	2.0
M2822-M2832	6.0	3.0
M2834-M2842	8.0	4.0
M2844-M2850	10.0	4.0

NPT connections available

Fluid cylinder materials

Forged	Cast
A350-LF2 Carbon Steel	Currently not available
Hi Strength Carbon Alloy Steel	
2205 Duplex Stainless Steel	

Special materials available on request

M28

Forged pump engineering dimensional outline

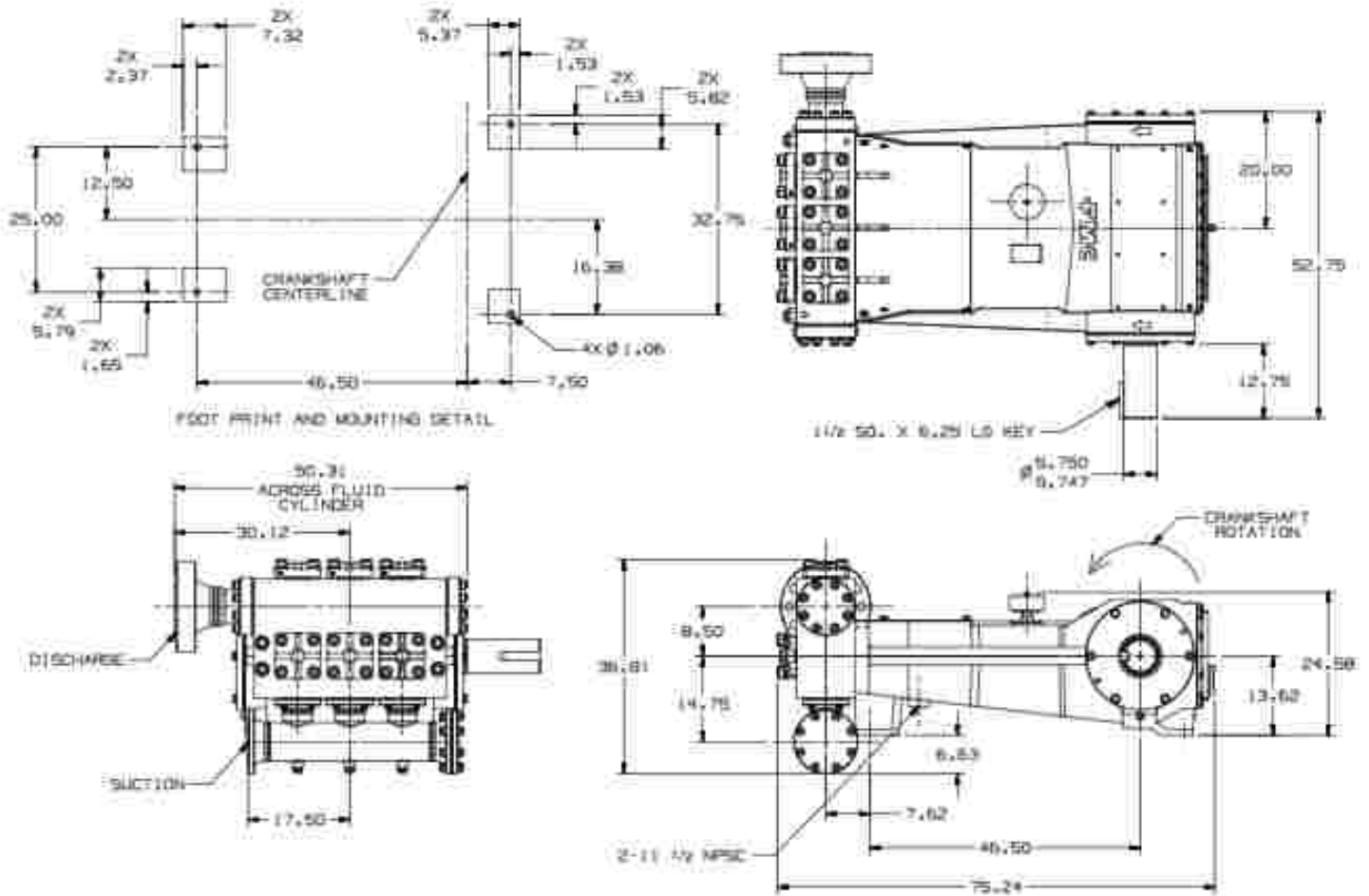

M28

Cast pump engineering dimensional outline

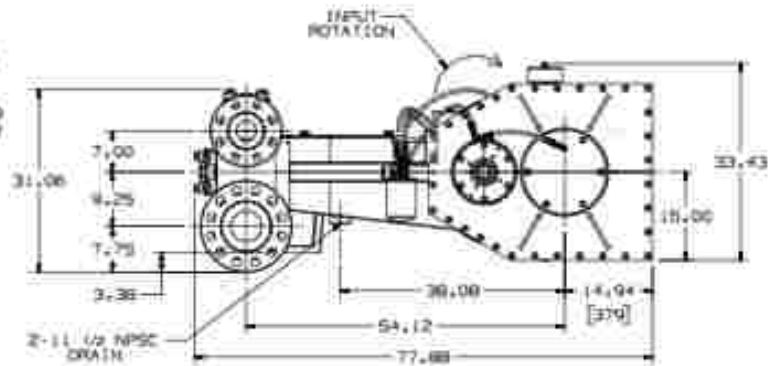
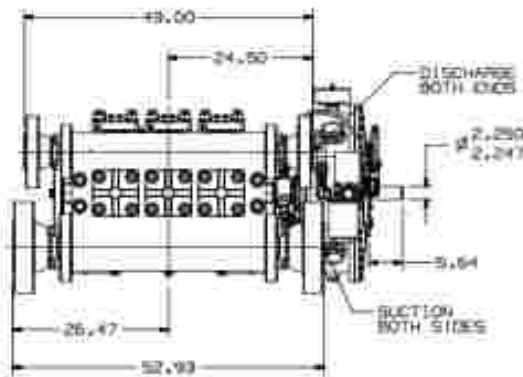
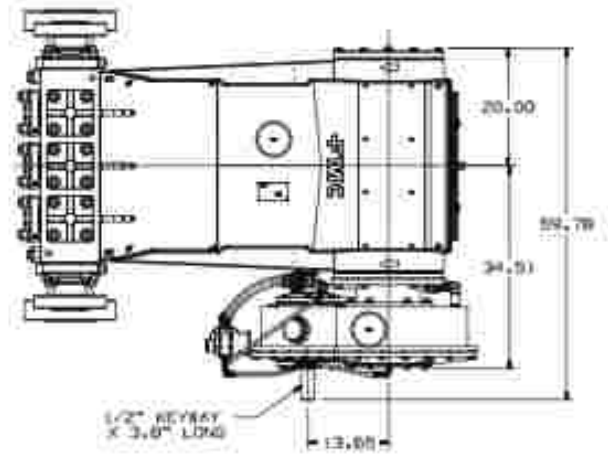
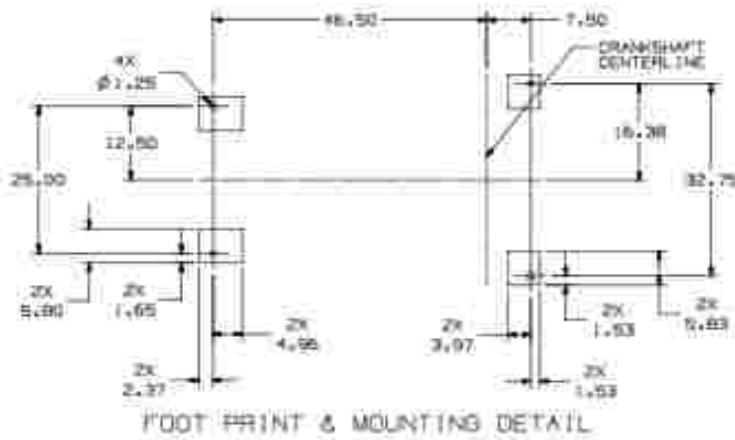

Q28

Specifications

Design Standard	API 674, Third Edition
Configuration	Horizontal Quintuplex Plunger
Number of Plungers	5
Continuous Duty	650 BHP
Intermittent Duty	800 BHP
Stroke Length	7.0 inches
Frame Load Rating	27,500 lbs
Pump Weight (Average)	13,000 lbs
Intermittent Duty Speed Rating	300 RPM
Continuous Duty Speed Rating	240 RPM
Minimum Speed *	100 RPM
Mechanical Efficiency	90%
Lubrication System	Splash, Gravity Return
Crankcase Oil Capacity	38 Gallons
Lube Oil Type	SAE 30
Fluid Temperature Range	-20 to 350 °F
Valve Types	Disc Valves, Abrasion Resistant Valves

Slower RPM can be achieved with the addition of a pressurized lubrication system

Bolt-on gearbox ratios available

6.17 : 1
6.50 : 1
7.30 : 1
9.57 : 1

Forged ISO drawing

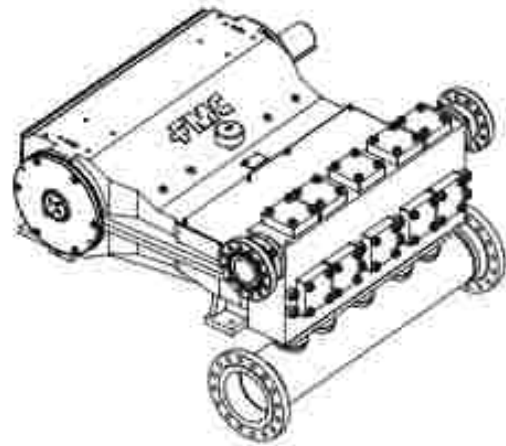

Cast ISO drawing

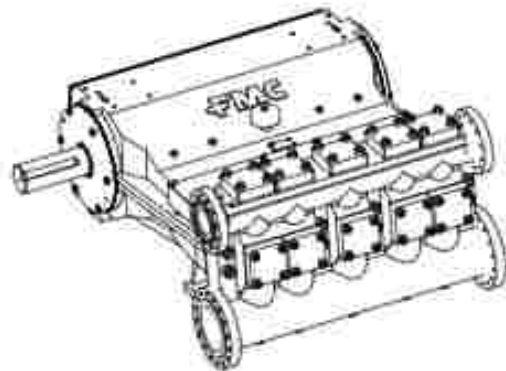

Q28

Performance data

Pump Model	Plunger Diameter (in)	Displacement (GAL/REV)	Maximum Pressure (PSI)	Pump Capacity (GPM @ Input Speed (RPM))					
				100 RPM	150 RPM	200 RPM	240 RPM	250 RPM	300 RPM
Q2814	1.750	0.3644	10,000	36	55	73	87	93	109
Q2816	2.000	0.4760	8,750	48	71	95	114	119	143
Q2818	2.250	0.6024	6,920	60	90	120	145	151	181
Q2820	2.500	0.7437	5,600	74	112	149	178	186	223
Q2822	2.750	0.8999	4,630	90	135	180	216	225	270
Q2824	3.000	1.0710	3,890	107	161	214	257	268	321
Q2826	3.250	1.2569	3,310	126	189	251	302	314	377
Q2828	3.500	1.4577	2,860	146	219	292	350	364	437
Q2830	3.750	1.6734	2,490	167	251	335	402	418	502
Q2832	4.000	1.9040	2,190	190	286	381	457	476	571
Q2834	4.250	2.1494	1,940	215	322	430	516	537	645
Q2836	4.500	2.4097	1,730	241	361	482	578	602	723
Q2838	4.750	2.6849	1,550	268	403	537	644	671	805
Q2840	5.000	2.9750	1,400	297	446	595	714	744	892
Q2842	5.250	3.2799	1,270	328	492	656	787	820	984
Q2844	5.500	3.5997	1,160	360	540	720	864	900	1,080
Q2846	5.750	3.9344	1,060	393	590	787	944	984	1,180
Q2848	6.000	4.2840	970	428	643	857	1,028	1,071	1,285
Q2850	6.250	4.6484	900	465	697	930	1,116	1,162	1,395

Standard connection sizes

Pump Model	Suction (in)	Discharge (in)
Q2814-Q2820	4.0	3.0
Q2814-Q2824	6.0	3.0
Q2826-Q2836	8.0	4.0
Q2838-Q2842	10.0	6.0
Q2844-Q2850	12.0	6.0

NPT connections available

Fluid cylinder materials

Forged	Cast
A350 LF2 Carbon Steel	Currently not available
Hi-Strength Carbon Alloy Steel	
2205 Duplex Stainless Steel	

Special materials available on request

Q28

Forged pump engineering dimensional outline

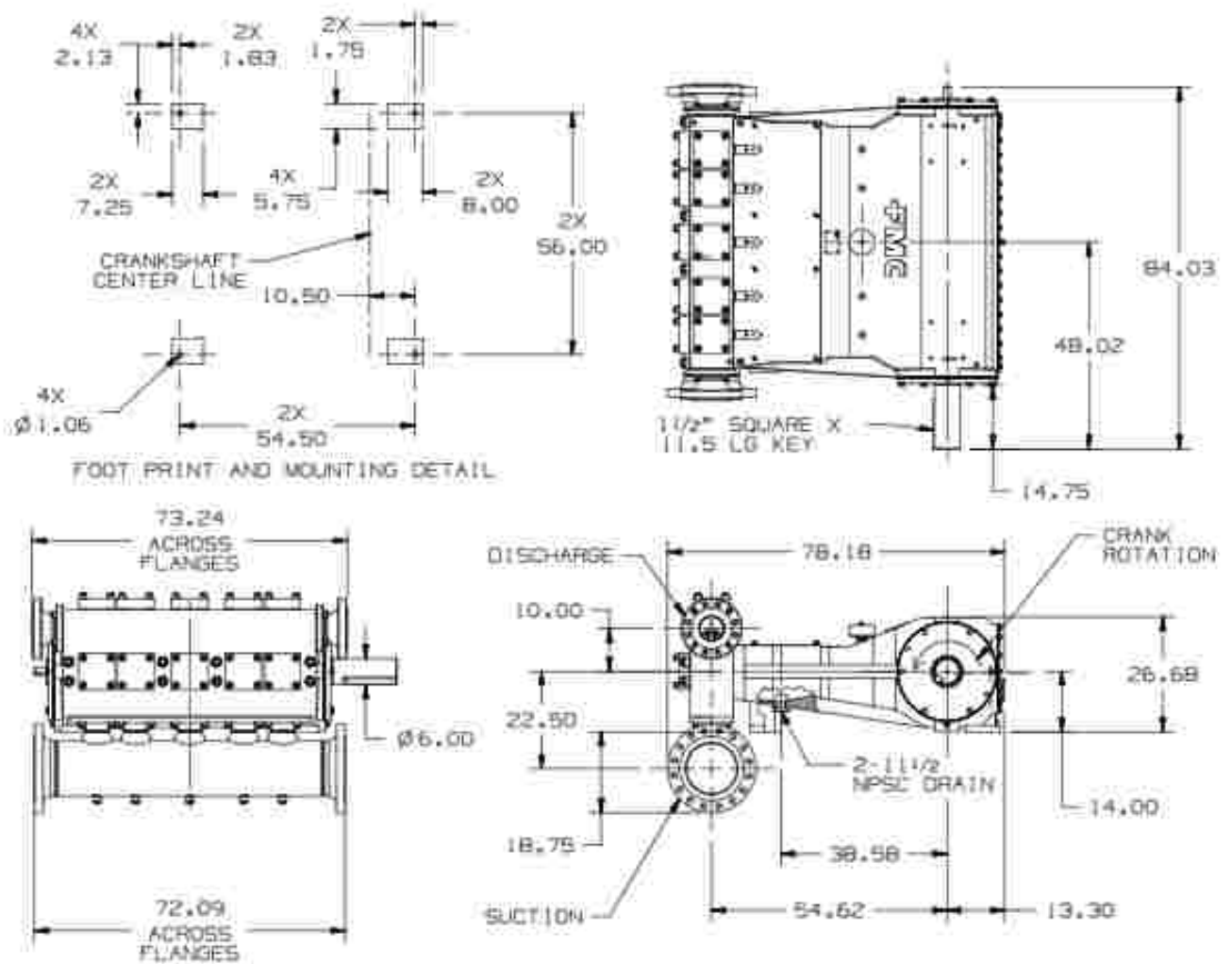

Q28

Cast pump engineering dimensional outline

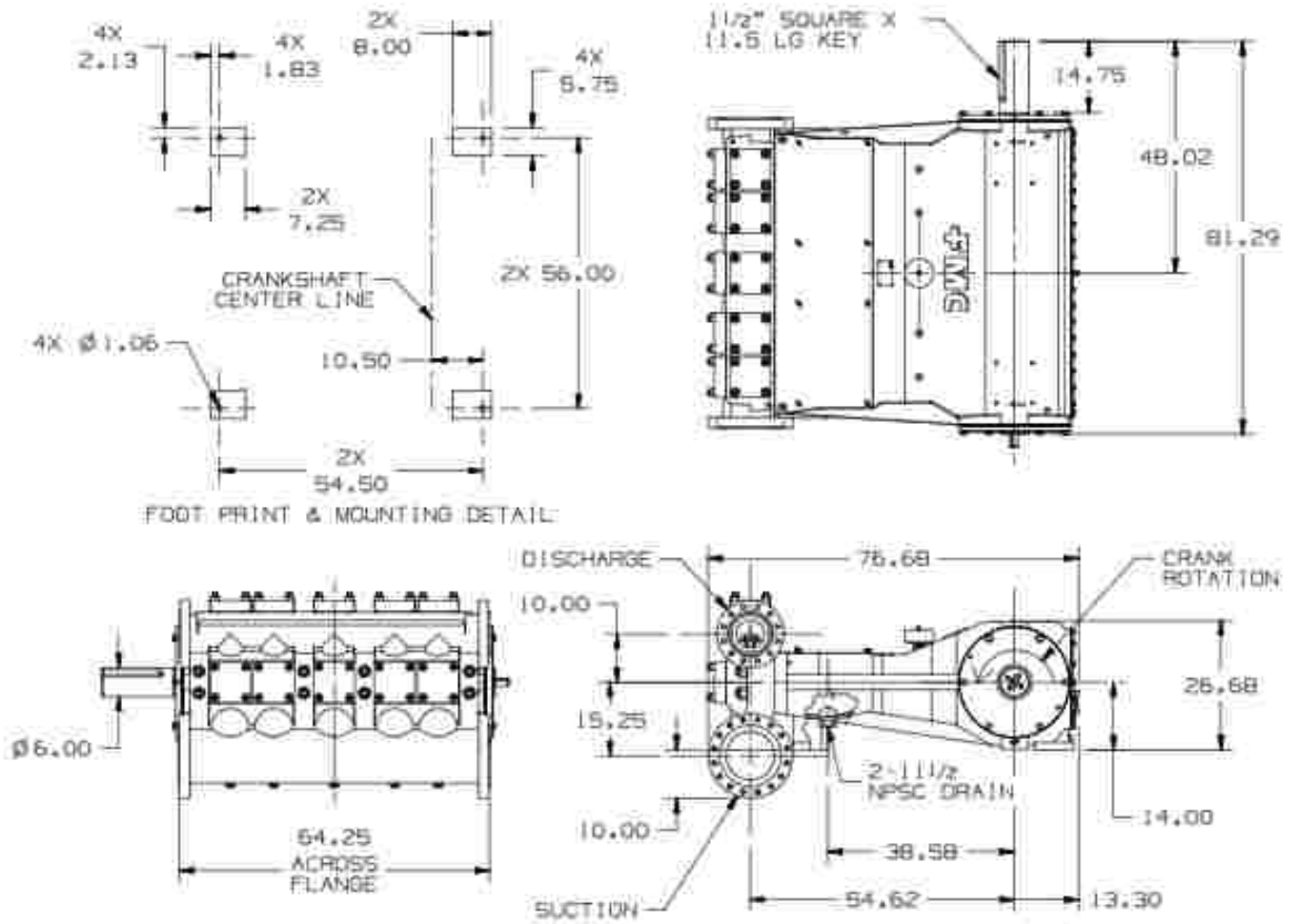

Q32

Specifications

Design Standard	API 674, Third Edition
Configuration	Horizontal Quintuplex Plunger
Number of Plungers	5
Continuous Duty	700 BHP
Intermittent Duty	1000 BHP
Stroke Length	8.0 inches
Frame Load Rating	30,000 lbs
Pump Weight (Average)	13,000 lbs
Intermittent Duty Speed Rating	300 RPM
Continuous Duty Speed Rating	210 RPM
Minimum Speed *	100 RPM
Mechanical Efficiency	90%
Lubrication System	Splash, Gravity Return
Crankcase Oil Capacity	38 Gallons
Lube Oil Type	SAE 30
Fluid Temperature Range	-20 to 350 °F
Valve Types	Disc Valves, Abrasion Resistant Valves

Slower RPM can be achieved with the addition of a pressurized lubrication system

Bolt-on gearbox ratios available

8.17 : 1
8.50 : 1
7.30 : 1
9.57 : 1

Forged ISO drawing

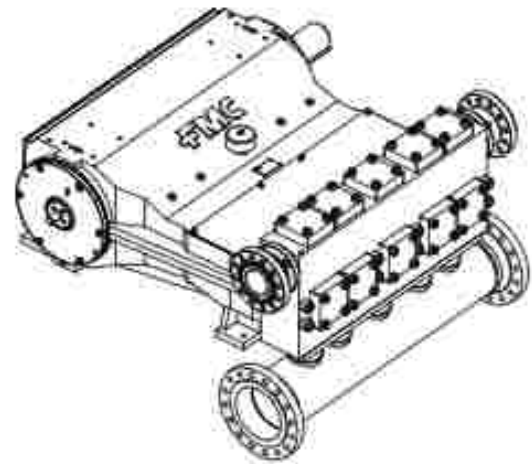

Cast ISO drawing

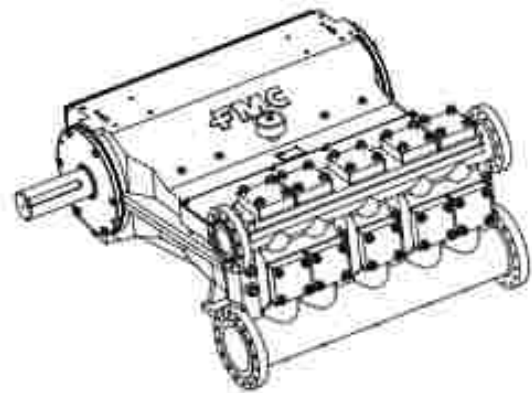

Q32

Performance data

Pump Model	Plunger Diameter (in)	Displacement (GAL/REV)	Maximum Pressure (PSI)	Pump Capacity (GPM @ Input Speed (RPM))					
				100 RPM	150 RPM	200 RPM	210 RPM	250 RPM	300 RPM
Q3214	1.750	0.4165	10,000	42	62	83	87	104	125
Q3216	2.000	0.5440	9,550	54	82	109	114	136	163
Q3218	2.250	0.6885	7,500	69	103	138	145	172	207
Q3220	2.500	0.8500	6,125	85	128	170	179	213	255
Q3222	2.750	1.0285	5,025	103	154	206	216	257	309
Q3224	3.000	1.2240	4,250	122	184	245	257	306	367
Q3226	3.250	1.4365	3,620	144	215	287	302	359	431
Q3227	3.375	1.5491	3,355	155	233	310	325	387	465
Q3228	3.500	1.6660	3,125	167	250	333	350	417	500
Q3230	3.750	1.9125	2,720	191	287	383	402	478	574
Q3232	4.000	2.1760	2,390	218	326	435	457	544	653
Q3234	4.250	2.4565	2,110	246	368	491	516	614	737
Q3236	4.500	2.7540	1,890	275	413	551	578	689	826
Q3237	4.625	2.9091	1,790	291	436	581	610	727	873
Q3238	4.750	3.0685	1,690	307	460	614	644	767	921
Q3240	5.000	3.4000	1,530	340	510	680	714	850	1,020
Q3242	5.250	3.7485	1,390	375	562	750	787	937	1,125
Q3244	5.500	4.1140	1,260	411	617	823	864	1,029	1,234
Q3246	5.750	4.4965	1,160	450	674	899	944	1,124	1,349
Q3248	6.000	4.8960	1,060	490	734	979	1,028	1,224	1,469
Q3250	6.250	5.3125	980	531	797	1,063	1,116	1,328	1,594

Standard connection sizes

Pump Model	Suction (in)	Discharge (in)
Q3214-Q3220	4.0	3.0
Q3214-Q3224	6.0	3.0
Q3226-Q3234	8.0	4.0
Q3236-Q3240	10.0	6.0
Q3242-Q3250	12.0	6.0

NPT connections available

Fluid cylinder materials

Forged	Cast
A350 LF2 Carbon Steel	Currently not available
Hi-Strength Carbon Alloy Steel	
2205 Duplex Stainless Steel	

Special materials available on request

Q32

Forged pump engineering dimensional outline

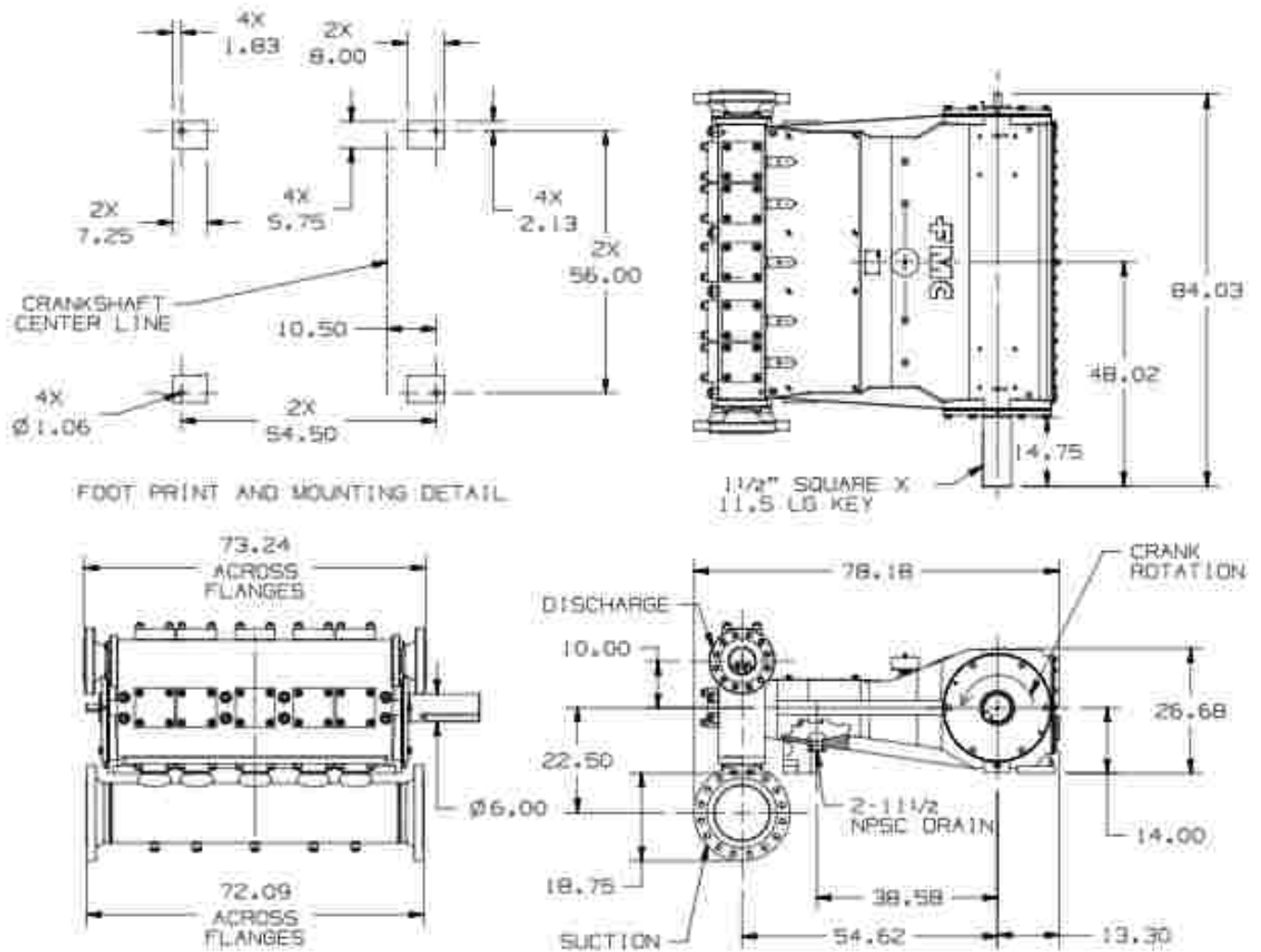

Q32

Cast pump engineering dimensional outline

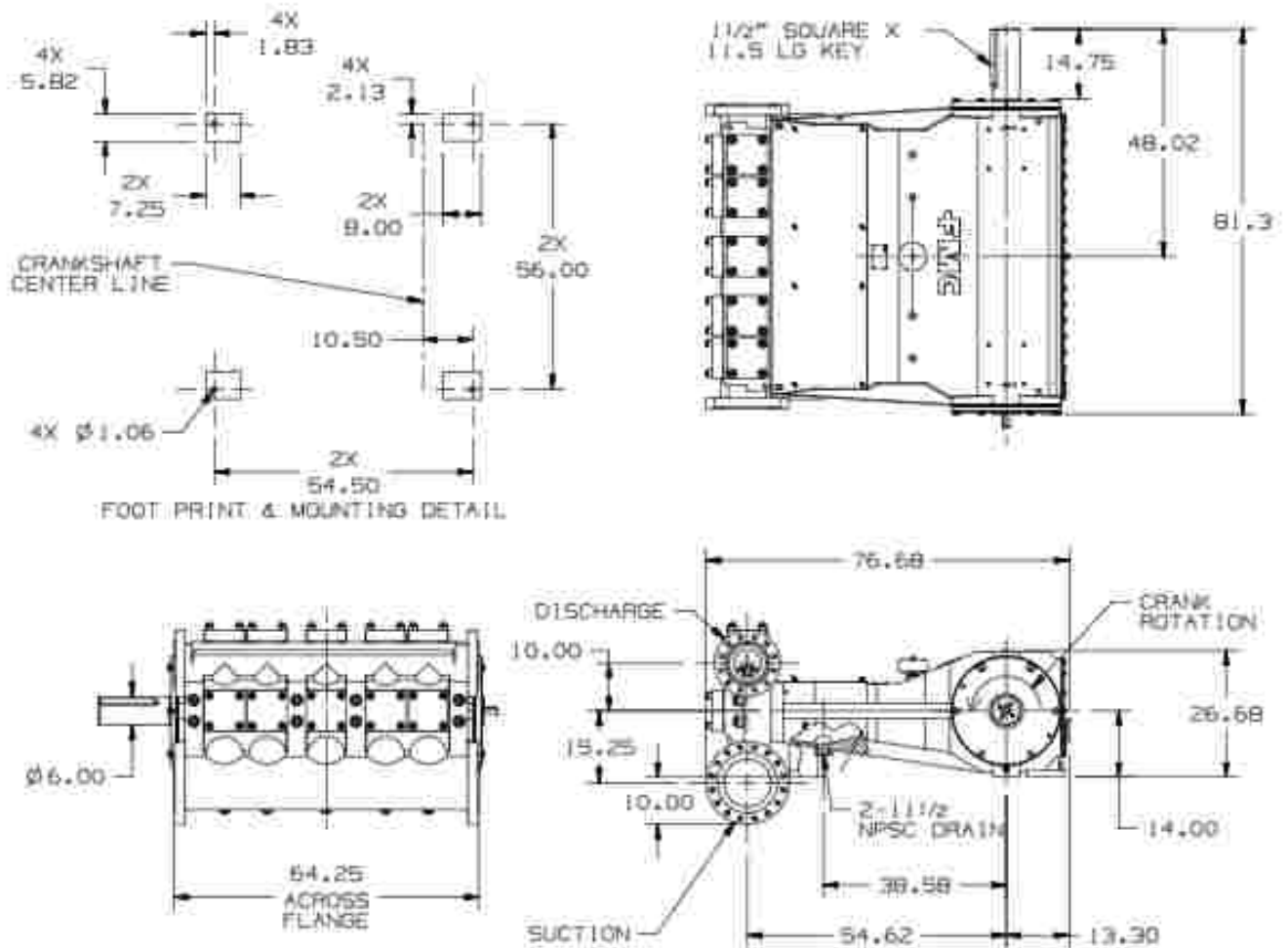

Notes

1. **CS** = Carbon steel
SS = Stainless steel
DX = Duplex stainless steel
AB = Aluminum bronze
DEL = Delrin disc valves
TI = Titanium disc valves
AR = Abrasion resistant valves
2. Horsepower based on 85 or 90% mechanical efficiency. Actual application horsepower requirements can be calculated using the equation:
$$\text{BHP} = (\text{GPM} \cdot \text{PSI}) / (1714 \cdot 0.85 \text{ or } 0.90)$$
3. Pump capacities shown are based on 100% volumetric efficiency.
4. Dimensions shown are for general sizing purposes and should not be used for construction. Contact TechnipFMC for actual dimensions of pump ordered.
5. Pump drawing dimensions in inches.
6. Take special consideration when calculating NPSHa. Recalculate NPSHa after pump model has been selected for more accurate values.
7. NPSHr values are in feet of water. If you are pumping a different liquid than water, convert the required NPSH from water to the liquid being pumped by dividing the published NPSHr value by the specific gravity of the liquid being pumped.
8. TechnipFMC recommends NPSHa (available) exceeds NPSHr (required) by 5 feet of water.
9. TechnipFMC published NPSHr values are based on test data collected on specific pumps at the factory and are estimated values. Actual NPSHr values for an ordered pump can only be determined by a factor test. For NPSH critical applications, contact the factory for additional information and request an NPSHr test performed on your pump before shipment.
10. There are many variations of packings available for every applications. Consult with TechnipFMC to determine the best option to suit your fluid type, temperature and lubrication needs.
11. When using a packing lubricator, a small amount of packing lubricant will enter the pumped liquid.
12. Tungsten coated stainless steel plungers are the most commonly used and well suited for all fluids. Solid ceramic plungers work well with abrasive fluids such as water applications but should not be used where thermal shock or flammable liquids or gases are present.
13. Consult with TechnipFMC on the correct grade of CS or SS to use for your application.
14. Adjusting Nuts that are made from SS and used in SS stuffing boxes have an anti-seize coating to prevent galling.
15. Vaporless Stuffing Boxes should be used when pumping a flammable or hazardous liquid that should be prevented from leaking to atmosphere.
16. TechnipFMC reserves the right to modify this information without prior notice.

Fluid end options

- ▶ **Material certification** Documentation of the material certification of the pressure containing fluid end components.
- ▶ **NACE** Used in sour (H₂S / Chlorides) applications where certain materials are not allowed due to corrosion and/or reduction of material strength.
- ▶ **Lubricated stuffing box** Ported stuffing box that allows a packing lubricant to be pumped directly into the packing area for better lubrications than an external drip. Used to reduce friction and extend the life of wearable components.
- ▶ **Vaporless stuffing box** Ported stuffing box with secondary packing that allows any leakage to be collected and sent to the vent manifold system. Packing lubrication is required for this option to lubricate and cool the secondary seals.
- ▶ **Flushable stuffing box** A ported stuffing box that allows a clean fluid to flush out contamination that can damage wearable components prematurely or to cool the friction surfaces.
- ▶ **Packing lubricator** Used in conjunction with a lubricated or vaporless stuffing box to provide forced lubrication to the stuffing box for reduced friction and extended life of the wearable components.
- ▶ **Sealed cradle** Provides a complete seal of the cradle area to prevent all leakage from exiting the cradle area except from the appropriate drain points.

- ▶ **Cradle purge system** Used in conjunction with a sealed cradle to purge the oxygen, flammable, or toxic gases from the cradle area with an inert gas such as Nitrogen. This would be used to prevent any hydrocarbon or other reactive exposure in the cradle area.
- ▶ **Vent manifold System** Used in conjunction with the vaporless stuffing box to collect any leakage for removal, collection and/or disposal. The vent manifold system uses an orifice to build back pressure and a pressure switch to send a signal for alarm and/or shutdown in the case that the leakage exceeds the set limit.

Valve options

- ▶ **AR Valves** Abrasion resistant valves use hardened metallic components and feature an angled seal to reduce the wear on the valves. An elastomeric seal traps abrasive particles from the pumped fluid and seals around them to avoid wash-out. When the temperature of the fluid exceeds the limits of the Urethane seal an metal-to-metal seal option is available.
- ▶ **Disc valves** The spring loaded disc valve is the most common type of valve used in reciprocating pumps. Stainless steel, Delrin, or titanium discs are available for a variety of fluid types, temperatures, and pressures.
- ▶ **Valve hold downs** Used in extremely hot or cold applications where the potential exists for the valve to unseat due to material expansion or contraction.

Plunger packing options

- ▶ **Braided packing** Braided ring (Rope) packing is made from braided strands material. They are designed to leak a minimal amount in order to ensure proper lubrication. Braided packing can be used in both adjustable and spring loaded packing arrangements.
- ▶ **V-ring packing** V-ring packing is molded from shaped elastomer and fiber sheets. They are designed to reduce leakage. Depending on the pumped fluid, v-rings may require additional lubrication. V-ring packing can be used with spring loaded arrangements and with header rings.
- ▶ **Header ring** Used in conjunctions with v-ring packing as a wiper for abrasive fluid particles to prevent them from wearing the primary packing. Also provides the energizing force to preload the v-ring packing.
- ▶ **Spring loaded (nonadjustable)** Packing Non-adjustable packing uses a spring to ensure the correct energizing load is applied to the packing. As the packing wears, the energizing load is automatically adjusted by the spring for optimal packing life.
- ▶ **Adjustable packing** Adjustable packing requires maintenance and allows the user to tighten the packing and reduce leakage to acceptable levels. Avoid over-tightening to optimize packing life.

Plunger options

- ▶ **Tungsten Carbide** The standard plunger option on a stainless steel base material for the best all-round resistance to abrasion and corrosion.
- ▶ **Ceramic** Ceramic plungers are very abrasion resistant, but due to susceptibility to thermal shock, they are not recommended for use with any flammable or hazardous fluids. Used in abrasive water based applications like saltwater disposal.
- ▶ **Chrome oxide** Recommended for use in amine or other fluids requiring restricted lubrication. One type of a chrome oxide coating is Rokide.
- ▶ **Premium tungsten carbide** Similar to the standard tungsten carbide plunger, but a higher grade of tungsten carbide coating.

Paint options

- ▶ **Standard blue** Standard water reducible enamel paint available for general pumping applications.
- ▶ **2-Coat epoxy** Used more frequently in on-shore oil and gas applications where extra coating protection is required.
- ▶ **3-Coat epoxy** Used more frequently in off-shore oil and gas applications where extra coating protection is required.

Power end options

- ▶ **Crankshaft extensions** Crankshaft side designation is classified by viewing the power end while standing at the fluid end side. Left hand (LH) is standard. Right hand (RH) is optional.
- ▶ **Double extended crankshafts** Crankshaft extension on both sides of the power end. Typically available on most pumps and is for drive from either side of power end or to drive accessory equipment.

Power end options (continued)

- ▶ **Crankshaft Extensions** Crankshaft side designation is classified by viewing the power end while standing at the fluid end side. Left hand (LH) is standard. Right hand (RH) is optional.
- ▶ **Double extended crankshafts** Crankshaft extension on both sides of the power end. Typically available on most pumps and is for drive from either side of power end or to drive accessory equipment.
- ▶ **Low oil level switch** Used to monitor the oil level in the power end of the pump and send a signal for alarm or shutdown in the case that the level falls too low for proper lubrication.
- ▶ **Power end pressure lube system** This system force feeds lubricant to the critical bearing surfaces to insure lubrication, minimize friction, reduce heat generation, and extend wear component life. Used in applications with high suction pressures, slow running speeds (less than 100 crankshaft RPM), and/or high power end temperatures due to high ambient temperatures. Driven by electric motor (standard) or by pump crankshaft extension.
- ▶ **Pressure switch (high and low)** Use in conjunction with the power end pressure lube system to send a signal for an alarm and/or shutdown in the case that the power end system drops below a minimal level indicating not enough pressure to feed the lubricant or above a maximum level indicating a clogged line or filter.
- ▶ **Oil coolers** Used in conjunction with the power end pressure lube system to cool the lubrication oil before returning to the power end. Typically used in applications with hot ambient temperatures, hot pumped fluid temperatures, and/or high suction pressures.
- ▶ **Oil heater** Used to maintain a minimum temperature of the power end lubrications to maintain a minimal lubrication oil viscosity in cold ambient temperatures while running or shutdown. An oil heater is also used to maintain a minimum power end temperature in humid environments to prevent water condensate forming in the power end and contaminating the lubrication oil.
- ▶ **Thermocouple interfaces** Thermocouple interfaces for temperature sensors are available on most pump models to measure power end and bearing temperatures for input into a monitoring and control system.
- ▶ **Vibration switch** Vibrations switches are available for direct mount to the pump power frame to monitor the pump vibrations and send a signal for an alarm and/or shutdown in the case that the vibration exceeds maximum limits.
- ▶ **Wrist pin needle bearings** Available on most pump models and used in applications with high suction pressure and/or high ambient temperature applications to allow for better lubrication on the wrist pin area.

Accessory options

- ▶ **Bolt-on gearbox** Available on some pump models to allow for direct mounting of a gearbox to reduce the overall cost, size and weight of a pump system. This allows the direct coupling of the drive to the pump reducing the extra components needed to couple with an external gear reducer or belts and pulleys.

Testing options - Certified or witnessed certified

- ▶ **Mechanical run test** All TechnipFMC pumps have mechanical run tests to insure the material, manufacturing, and assembly quality of the pump assembly. The test is run at the maximum speed and rated pressure for a specified minimum time based on pump model.
- ▶ **Hydrostatic fluid cylinder test** When required by customer specifications, or API Standards, fluid cylinders will be hydrostatically tested. All fluid cylinders for API pumps with suction and discharge flanges are to be hydrostatically tested. Fluid cylinders are tested to 1.5 times its respective rated suction and discharge pressure for 30 minutes.
- ▶ **Performance test** When required by customer specifications, pumps will have full performance tests that measure and record specific data that allows comparison of actual input and output parameters to determine pump efficiencies. Typically run at the normal operating condition of the application provided by the customer for 1 hour.
- ▶ **NPSHr test** When required by customer specifications, net positive suction head required (NPSHr) test is the factory test to measure the minimum amount of suction pressure required for the pump to operate with no more than a 3% reduction in flowrate due to cavitation. Typically the NPSHr test is run at the normal operation condition of the application provided by the customer. This test can be repeated up to 5 total points for curve generation when required by the customer.

Service options

- ▶ **Short term storage for severe environments**
Proper storage of your TechnipFMC pump will insure that it is ready for service when started. TechnipFMC pumps come from the factory without crankcase oil and are prepared for storage periods of up to six (6) months in proper environmental conditions. Indoor storage in a dry, temperature-controlled location is always recommended. If pumps are to be stored short term (less than six (6) months) in a severe environment, they should be prepared using the TechnipFMC procedures outlining "Short Term Storage for Severe Environments" to protect the power end components from rusting and seizing due to the lack of lubricant and/or preservative.
- ▶ **Long term storage**
Proper storage of your TechnipFMC pump will insure that it is ready for service when started. TechnipFMC pumps come from the factory without crankcase oil and are prepared for storage periods of up to six (6) months in proper environmental conditions. Indoor storage in a dry, temperature-controlled location is always recommended. If the pump is to be stored, or is inactive, for periods in excess of six (6) months, it is necessary to prepare the pump as outlined by TechnipFMC's "Long Term Storage" procedure to protect the power end components from rusting and seizing due to the lack of lubricant and/or preservative.
- ▶ **Engineering application training**
TechnipFMC provides a complete in-house engineering training course for design, application, and maintenance engineers on basic to advance practical concepts for the proper selection, installation and application of reciprocating pumps and systems.
- ▶ **Maintenance training**
TechnipFMC provides a complete in-house maintenance training course for the maintenance technician and manager for reciprocating pumps and pump systems.
- ▶ **Pump commissioning**
Commissioning of a pump unit before start up at the application sight is crucial to the success of the pump over the lifetime of the pump system. This is also a good time for the maintenance staff to review the important aspects of the pump system. TechnipFMC and its distributors are available to help in the commissioning and start up process.

Reference calculations

Pump displacement [GPR] $GPR = d^2 \times S \times Np \times 0.0034$

Pump displacement [GPM] $GPM = (RPM \times GPR \times VE)$

Piston/plunger/rod load [lbf] $RL = Ap \times PSI$

Fluid velocity [ft/sec] $FV = \frac{(GPM \times 0.321)}{FA} = \frac{(0.41 \times GPM)}{d^2}$

Flow area of pipe [in²] $FA = d^2 \times 0.7854$

Static head of liquid [ft of water] $Hs = (2.31 \times PSI) \times S.G.$

Acceleration head [ft of liquid] $Ha = \frac{(L \times V \times N \times Q)}{(K \times g)}$

NPSHa [ft of water] $= Hs + Pa - Pv - Hf - Ha$

Assumes tank at atmospheric pressure otherwise, add tank pressure.

Absolute viscosity [cp] $= S.G. \times cSt$

Torque [ft-lb] $T = \frac{(HP \times 5252)}{RPM}$

Brake horsepower [hp] $HP = \frac{(GPM \times PSI_{discharge})}{1714 \times ME}$

Excluding suction pressure

Brake horsepower [hp] $HP = \frac{(GPM \times PSI_{discharge})}{(1714 \times ME)} - \frac{(GPM \times PSI_{suction} \times (ME - 0.05))}{1714}$

Including suction pressure

Abbreviations

Ap	Area of piston or plunger in square inches	L	Length in feet
C	Constant (0.066 Triplex, 0.200 Duplex, 0.040 Quintuplex)	ME	Mechanical efficiency (90% for non-internal gear reduction, 85% for internal gear reduction)
d	Diameter in inches	N	Pump speed (RPM)
g	Gravity (32.2 ft/sec)	Np	Number of pistons or plungers
GPM	Gallons per minute	Pa	Atmospheric pressure in feet of water
Ha	Acceleration head in feet of liquid	Pv	Vapor pressure in feet of water
Hf	Friction loss in feet of water	PSI	Pounds per square inch
Hs	Static head in feet of water	S	Stroke-length in inches
K	Constant 1.4 Deaerated water 1.5 Water, Glycol, Amine 2.0 Most hydrocarbons 2.5 Hot oil	S.G.	Specific gravity
		V	Velocity of fluid in suction line
		VE	Volumetric efficiency

TechnipFMC
One St Paul's Churchyard
London, U.K. EC4M 8AP
Tel: +44 (0)20 3429 3950

TechnipFMC
89 avenue de la Grande Armée
75116 - Paris - France
Tel: +33 (0)1 47 78 24 00

TechnipFMC
1 Subsea Ln.
Houston, Texas 77044
Tel: +1 281 591 4000

TechnipFMC.com

Follow us on    

TechnipFMC plc is registered in England and Wales (Company No. 09909705), with registered offices at One St. Paul's Churchyard, London, EC4M 8AP.

© TechnipFMC 2017