

MISWACO

User Guide



MONGOOSE* & MEERKAT* PT Shakers

UL/ATEX Approved

Worldwide Headquarters

P.O. Box 42842

Houston, TX 77242-2842

Tel: 281-561-1300

Fax: 281-561-1441

www.miswaco.com

E-mail: questions@miswaco.com



DISCLAIMER

Recommendations made by M-I SWACO are advisory only. M-I SWACO shall not be liable under any guarantees or warranties, expressed or implied, in any manner or form, AND ALL WARRANTIES, EXPRESSED OR IMPLIED, ARE HEREBY SPECIFICALLY EXCLUDED, and M-I SWACO shall not be liable for the failure to obtain any particular results from the use of any recommendation made by it or from the use of this material. In no event shall M-I SWACO be liable for incidental or consequential damages.

ASSEMBLIES COVERED IN MANUAL

This user guide is for assemblies 9674xxx, 9672xxx, 9872xxx and MK3C00xxx.

NOTE: Information included within this manual supports multiple configurations and/or models. See Installation, Operation & Maintenance (IOM) manuals for further details.

© Copyright 2009 M-I SWACO

Publication Date: June 2009

All other products, brand, or trade names used in this publication are the trademarks or registered trademarks of their respective owners. All rights reserved. This publication is the property of, and contains information proprietary to M-I SWACO. No part of this publication may be reproduced in any form or by any means, including electronic, mechanical, or otherwise, without the prior written permission of M-I SWACO.

Information contained within this publication is subject to change without notice.

*Mark of M-I L.L.C.

TABLE OF CONTENTS

Item Description	Page Number
Section 1.0 Introduction	2-6
Intended Usage	2
Symbols	2-3
Safety	3-4
Personal Protective Equipment (PPE)	4
Functional Description	4
Fluid Distribution Systems	5-7
Section 2.0 Preparation	7-12
Unpacking	7-8
Lifting & Handling	8
Equipment Location	8-9
External Power/Electrical Connections	10-11
Preservation & Storage	12-13
Decommissioning Procedures	12
Section 3.0 Operating Instructions	12-17
Adjustable Equipment Parameters	12-13
Shaker Speed	14
Equipment Start-Up	14-15
Controlled Shutdown	15
Screen Handling	15-17
Section 4.0 Preventative Maintenance	17-20
Safety Related Maintenance Procedures	17
Motor Maintenance	18-19
Isolation Springs	19
Greasing Deck Adjustment Jack	19
Recommended Preventative Maintenance Schedule	20
Section 5.0 Troubleshooting	20
Section 6.0 Maintenance Procedures	21-28
Screen Gasket Replacement	21
Isolation Spring Replacement Procedures	21
Vibrator Removal & Installation	22-23
Cable Gland Assembly Instructions	23-24
Elevator Jack Replacement	25
Shaker Washer Down Procedures	25-26
Surface Corrosion Removal	26
Adjusting Brake for Elliptical (Small) Motor	26-27
Section 7.0 Rig Critical Recommended Spare Parts List	29-38
Section 8.0 Electrical Schematics	29-43

SECTION 1.0 INTRODUCTION

INTENDED USAGE

This documentation is intended for use by field engineering, installation, operation and repair personnel for the proper installation and maintenance of equipment manufactured by M-I SWACO. Every effort has been made to ensure the accuracy of the information contained herein. M-I SWACO will not be held liable for errors in this material, or for consequences arising from misuse of this material.

SYMBOLS

Notes, Cautions & Warnings

Notes, cautions and warnings appear throughout this manual to provide additional information and to advise on specific actions to protect personnel from potential injury or fatal conditions. They also inform of actions necessary to prevent equipment damage or conditions that may void equipment warranties.

ATTENTION This symbol draws attention to safety measures which **MUST** be observed to prevent **DAMAGE** to equipment.

CAUTION This symbol draws attention to safety measures which **MUST** be observed to prevent an **ACCIDENT** from occurring.

WARNING This symbol draws attention to safety measures which **MUST** be observed to prevent **PERSONAL** injury.

NOTE: This symbol draws attention to general operating notes which should be especially observed.

Packaging

The symbols that may be shown on the package are noted below. Their meanings are as follows:

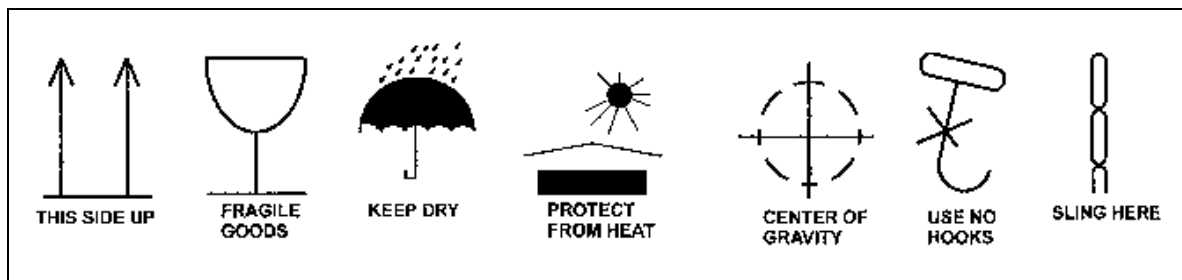

Safety Warning Icons & Explanations

Refer to the illustrations on the following page to easily recognize safety concerns and responsibilities to follow. Each illustration is accompanied with an explanation for the user to be readily alert for and pay attention to during operation and maintenance of the equipment.

SAFETY WARNING ICONS & EXPLANATIONS



ELECTRICAL: Electrical wire to hand with electricity symbol running through indicates shock hazard is present.



HEAVY PARTS: Hand with heavy object on top indicates heavy parts can crush and harm.



HEAVY PARTS: Foot with heavy object on top indicates heavy parts can crush them.



MOVING PARTS: Human figure with an arm caught between gears indicates moving equipment parts present a danger to life or limb.



MOVING PARTS: Hand with fingers caught between gears indicates moving equipment parts present a danger to life or limb.



CHEMICAL: Drops of liquid on hand indicates material will cause burns or irritation to human skin or tissue.



EXPLOSION: Rapidly expanding symbol indicates material may explode if subjected to high temperatures, sources of ignition or high pressure.



FIRE: Flame indicates material may ignite and cause burns.



POISON: Skull and crossbones indicate that a material is poisonous or is a danger to life.



VAPOR/FUMES: Human figure in a cloud indicates that material vapors/fumes present a danger to life or limb.



LOCK OUT: Open lock with direction arrow indicates to operator to ensure ALL input power sources are locked out and tagged out according to regulation.



HOT: Hand over flame indicates that surfaces may be hot.



FLYING PARTICLES: Arrows bouncing off face indicates parts/particles flying through air will harm face and present a danger to life or limb.



HELMET PROTECTION: Arrow bouncing off head with helmet indicates falling parts present a danger to life.



EAR PROTECTION: Headphones over ears indicate noise level will harm ears.



ELECTRICAL: Electrical wire to arm with electricity symbol running through human body indicates shock hazard is present.



READ MANUAL: Wrench over book indicates the necessity to read the instructions before performing any operations .

SAFETY

Equipment manufactured by M-I SWACO is installed and operated in a drilling rig environment involving hazardous operations. Proper care is important for safe and reliable equipment operation and rig personnel safety. Operation and service procedures described within this manual are recommended methods of performing proper operations and safety methods. Consult Local or National codes for any other safety regulations required for this type of environment.

Safety Procedures

CAUTION



Read the following procedures BEFORE installing or performing maintenance on M-I SWACO equipment to avoid injuries to personnel or damage to equipment.

All personnel performing installation, operations and maintenance procedures on this equipment should be trained on rig safety, operations and maintenance of this equipment.

WARNING



BEFORE starting any parts replacement procedure or general maintenance, initiate a controlled shutdown. Lockout/tag out unit.

- Do NOT perform maintenance or repairs to equipment while unit is in operation. Have a certified electrician ensure power supplies are isolated BEFORE performing any maintenance on unit.
- Wear Personal Protective Equipment (PPE).
- Clean all parts and work area.
- Block up and secure heavy parts BEFORE working beneath unit or parts.
- When heavy lifting is involved, always seek assistance.
- Ensure all tools, old parts, nuts, bolts washers, etc. are removed BEFORE restarting unit after maintenance.

PERSONAL PROTECTIVE EQUIPMENT (PPE)

All personnel working on or around M-I SWACO equipment MUST wear Personal Protective Equipment (PPE) including an approved hard hat, safety glasses/shield; gloves and outer garments unless Local or National codes require different PPE apparel.

FUNCTIONAL DESCRIPTION

The shaker's basic function is to provide primary solids removal from both oil based mud (OBM) and water based mud (WBM) during drilling operations.

The Mongoose* with four screens per basket, and the Meerkat with three screens per basket, along with an adjustable deck angle allows flexible control of fluid pool depth and beach length enabling the user to meet a wide variety of drilling conditions.

The unique motor mounting of the two motor shaker vibrators produces a true linear motion. The three (3) motor shaker has an adjustable dual motion drive allowing the user to switch between linear and balanced elliptical motion while unit is in operation.

Each unit has a fluid distribution box. Options include:

- Header Box
- Possum Belly with Butterfly Valve
- Possum Belly with Knife Gate

NOTE: Refer to the Installation, Operation and Maintenance manuals for further details.

FLUID DISTRIBUTION SYSTEMS

Shaker with Header Box

- The fluid distribution system is at the rear of the shaker basket and is mounted above the screen deck. (Refer to Figures 1 and 2.)
- Fluid is redirected from the inlet line through the header box into a half pipe at the rear of the basket.
- Since fluid distribution is mounted above the screen deck, no trap exists to collect solids.
- As fluid passes through the diverter box, it sweeps the box clean.



Figure 1
Carbon Steel Header Box

Shaker with Possum Belly with Butterfly Valve Bypass

- The butterfly valve is located below the main inlet on the possum belly. (Refer to Figure 3.)
- Use to manually open or close the bypass.
- When CLOSED, fluid flow is directed through the possum belly to the shaker bed.
- OPEN the bypass by turning butterfly valve 90°.
- When butterfly valve is opened, fluid is redirected into the skid bypassing the screens.



Figure 2
Stainless Steel Header Box



Figure 3
Possum Belly with Butterfly Valve

Shaker with Possum Belly with Knife Gate Bypass

- The pivoting knife gate for single shakers is manually raised or lowered to operate the bypass. (Refer to Figure 4.)
- When the knife gate is opened, fluid is redirected into the skid bypassing the screens.



Figure 4
Possum Belly with Knife Gate Bypass

Dual & Triple Shakers with Common Possum Belly with Knife Gate Bypass

- The knife gate is controlled by a single, turning handwheel. (Refer to Figures 5 & 6.)
- When the knife gate is opened, fluid is redirected into the skid bypassing the screens.
- The manually operated slide gates are also used to control the flow rate.



Figure 5
Dual Shaker with Common
Possum Belly with Knife Gate

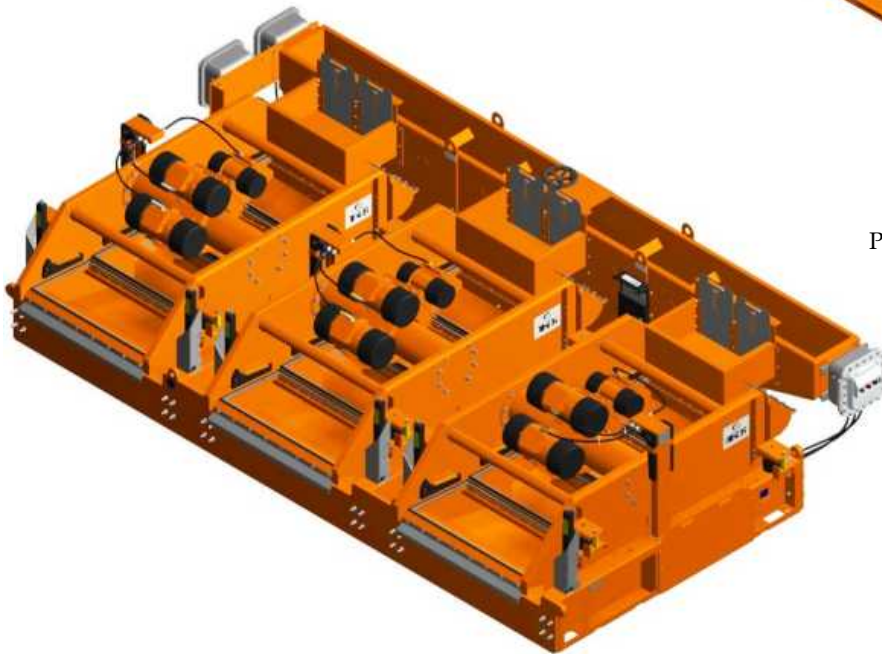

Figure 6
Triple Shaker with
Common Possum Belly
with Knife Gate

Quad Shakers with Feed Manifold Assembly, Header Boxes & Butterfly Valve Bypasses

- Mud feeds into the back of the feed manifold assembly with the flow evenly distributed to each of the header boxes. (Refer to Figure 7.)
- Butterfly valves located at each header box are used to open or close flow to a particular shaker.
- Butterfly valves located at the top of the feed manifold are used to close off flow to shakers enabling the use of a cement bypass.

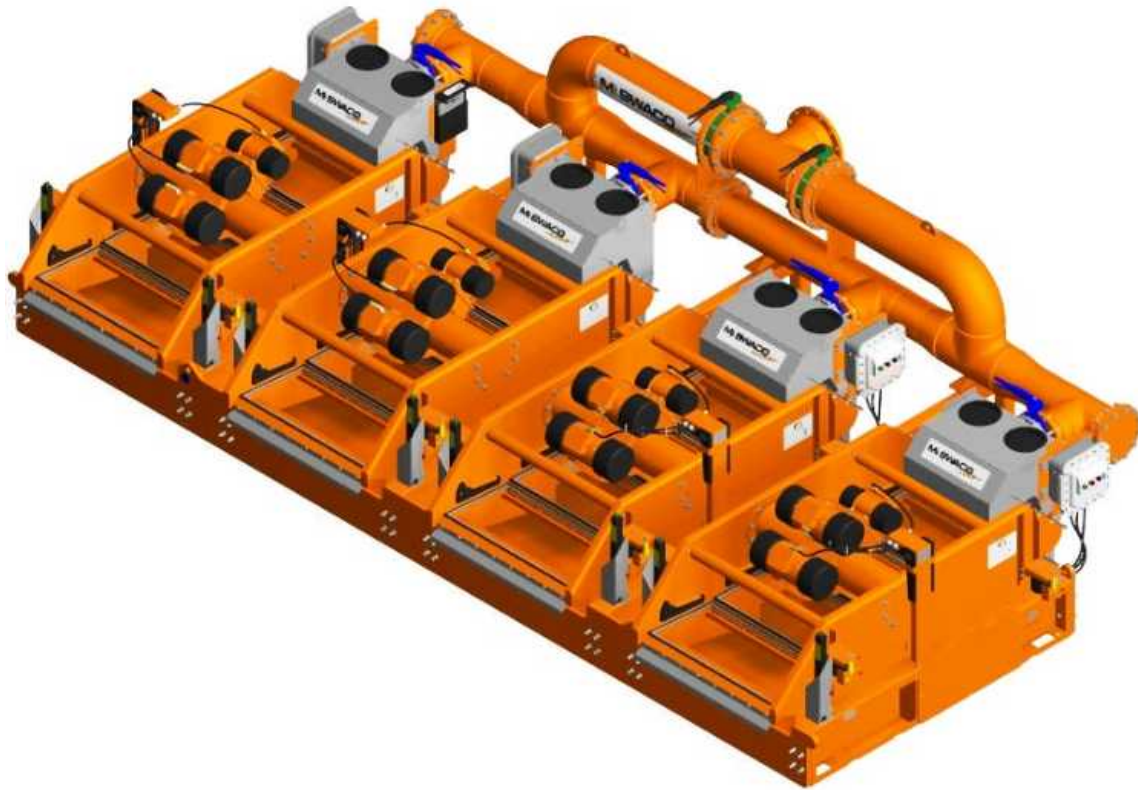

Figure 7
Quad Shaker with Feed Manifold Assembly,
Header Boxes & Butterfly Valve Bypasses

SECTION 2.0 PREPARATION

UNPACKING

Inspect all goods as received from shipping company BEFORE setting up and operating the shale shaker. Report a claim for damage or loss immediately to both the carrier and M-I SWACO. Also check bill of lading for any separately shipped items, including manuals and CDs. Once an order is confirmed as received completed in an undamaged condition, installation can begin.

CAUTION

Special shipping brackets are used to retain the basket onto the skid during shipping. Keep them secured until equipment is placed in its final location. Keep brackets for future movement or long term storage of the unit.
(Refer to Figure 8.)



Figure 8
Shipping Bracket

LIFTING & HANDLING

Always use trained personnel for lifting and loading operations. Ensure lifting equipment is suitable for purpose and is certified where necessary.

Use the four (4) lifting lugs located at each of the four corners of the unit. A label shown in Figure 9 indicates location of each lifting lug on the unit.

ATTENTION

Perform structural checks on the deck beams to ensure they can support applied loads (twice the shaker weight) of equipment.



Figure 9
Lifting Lug Label

TABLE 1. UNIT WEIGHTS & DIMENSIONS

Unit Description	Approximate Unit Dry Weight	Unit Dimensions
Single Mongoose PT	1406 to 1491 kg (3100 to 3285 lbs.)	1600 mm x 2359 mm x 1346 mm (63" x 92.9" x 53")
Single Meerkat PT	1216 to 1300 kg (2680 to 2865 lbs.)	2087.8 mm x 1750 mm x 119.8 mm (82.2" x 68.9" x 74.2") to 2575.6 mm x 1750 mm x 1198.8 mm (101.4" x 68.9" x 47.2")
Dual Mongoose PT	4037 to 4264 kg (8900 to 9400 lbs.)	3689 mm x 3241 mm x 1367 mm (145.3" x 127.6" x 53.8)
Dual Meerkat PT	3335 to 3552 kg (7351 to 7830 lbs.)	2784 mm x 3905 mm x 2691.2 mm (109.62" x 153.75" x 105.95")
Dual Meerkat LP	3302 kg (7290 lbs.)	3993 mm x 2464 mm x 1270 mm (157.2" x 97" x 50.06")
Triple Mongoose PT	5871 to 6110 kg (12,943 to 13,471 lbs.)	5283 mm x 2410 mm x 1367 mm (208" x 94.9" x 59.8")
Quad Mongoose PT	8709 to 9162 kg (19,200 to 20,200 lbs.)	3684 mm x 7580 mm x 2586 mm (145.1" x 298.4" x 101.8")

EQUIPMENT LOCATION

The shaker is supplied with an integral skid and is positioned directly onto the deck or above sand traps as required. Install, operate and maintain equipment only with qualified personnel. Locate unit at proper site.

If unit is installed indoors, adequate ventilation is necessary. Ventilation set-up may be done by qualified M-I SWACO personnel or by the customer.

The carbon steel feeder assembly has an installation guide painted on the rear of the feeder for mounting the inlet pipe which can accommodate 6", 8" and 10" inlet pipe sizes. The stainless steel feeder assembly is designed to allow users to bolt on a 10", 150 lb. pipe flange permitting true cold installation. Check all nuts, bolts and fasteners for tightness. (Refer to Figure 10.)

The units are designed on a modular basis and can be disassembled into individual components for easier installation.



Figure 10
Inlet Pipe & Flange
Connected to Header Box

TABLE 2. WEIGHTS PER MODULAR COMPONENT

Unit Description	Basket Assembly (Without Motors)	Skid	Motors	Possum Belly	Header Box
Single Mongoose PT	622 kg (1372 lbs.)	324 kg (715 lbs.)		268 kg (591 lbs.) Knife Gate Bypass Units 189 kg (417 lbs.)	
Single Mongoose LP		159 kg (350 lbs.)		153 kg (338 lbs.)	
Single Meerkat PT	518 kg (1141 lbs.)	273 kg (602 lbs.)	Small Motors 44 kg (96 lbs.) Large Motors 98 kg (216 lbs.)	268 kg (591 lbs.) Knife Gate Bypass Units 189 kg (417 lbs.)	Carbon Steel 128 kg (283 lbs.) Stainless Steel 120 kg (265 lbs.)
Single Meerkat LP		135 kg (297 lbs.)	153 kg (338 lbs.)		
Dual Mongoose PT		1531 kg (3375 lbs.)	545 kg (1202 lbs.)		
Dual Meerkat PT		502 kg (1107 lbs.)	82 kg (180 lbs.)		
Dual Meerkat LP		2675 kg (5900 lbs.)	545 kg (1202 lbs.)		
Triple Mongoose PT		2388 kg (5264 lbs.)	1597 kg (3521 lbs.)		
Quad Mongoose PT					

EXTERNAL POWER/ELECTRICAL CONNECTIONS (UL PANEL)



WARNING

BEFORE starting any parts replacement procedure or general maintenance, initiate a controlled shutdown. Lockout/tag out unit.

Start-Up

NOTE: Refer to the Wiring Schematics in Section 8 of this User Guide.

Inlet port is located on side of control box. (Refer to Figure 11.)

- Remove plug seal on control panel box.
- Insert cable gland and wires through connection port.

NOTE: The green wire is the grounding lead and the white, red and black wires are all LIVE power leads.

- Attach (crimp) an eyelet wire connector to the wire ends of the green grounding cable. (Refer to Figure 12.)
- Loosen screws on power distribution box.
- Insert bare wire endings of the power leads into power distribution box.
- Retighten screws on power distribution box once wires are in place.
- Inspect o-ring seal on door surface. Replace if damaged.
- Install ALL bolts to completely close door.



Figure 11
Cable Gland Connection Port

Three Power Source Cables (Power Leads)- Inserted Into Power Distribution Box

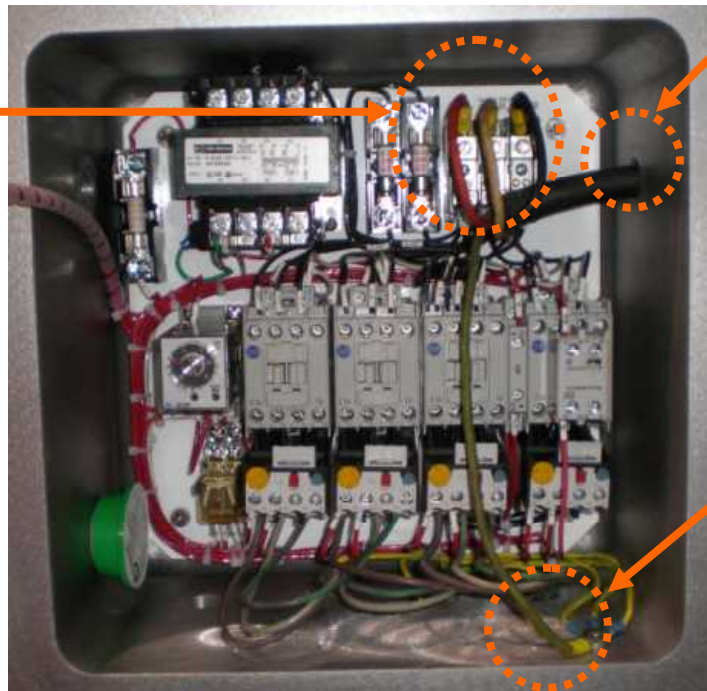

Cable Gland Connection Port (Interior View of Control Box)

Green Grounding Cable

Figure 12
Connection to Outside/External Power
(Interior View of Control Box)

Initializing Procedures



WARNING

Perform lockout/tagout procedures to isolate rig power supply.

- Remove vibrator covers and verify counter-weight. (Refer to Figure 13.)

NOTE: Large motors (one piece weights) are fixed at 100%. Ensure smaller motors are pre-set at 100%.

- Re-assemble one cover to each vibrator; leaving one cover off of each vibrator.
- Bump start motors to check rotation.



Figure 13
Small Motor Pre-Set

WARNING



Keep all guards in place at all times to avoid exposure to parts rotating at high speeds. When power is on, severe injury can occur if hands or feet reach inside unit.

NOTE: Bump start motors by pushing START button located on control panel. Next, quickly push STOP button on control panel.

- Check direction of top counter-weights. Vibrators should rotate as indicated in Figure 14.

WARNING



Perform lockout/tagout procedures to isolate rig power supply.

- Re-install all counterweight covers. Start up unit and run for approximately 1 hour. Allow enough time for bearings to reach normal running temperature.



WARNING

All components inside control box are LIVE and present a shock hazard.

- Check current drawn by vibrators from the control panel using an amp meter (a clamp-on current meter is recommended).
- Clamp around each motor cable lead to get current readings. (Refer to Figure 15.)
- Bolt control panel cover on panel.

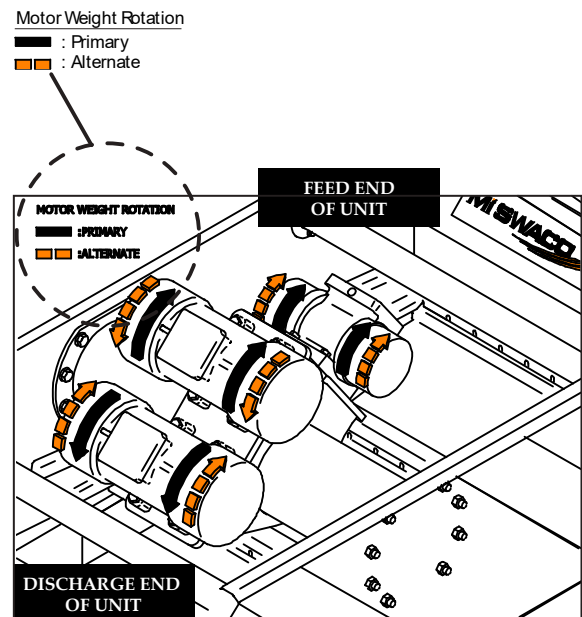

Figure 14
Vibrator Rotational Direction

PRESERVATION & STORAGE

Storage of Non-Commissioned Equipment

Equipment can be stored (upon arrival) in the shipping crate for a 12 to 24 month preservation period. Do NOT expose equipment to dust, vibration or extreme weather conditions (such as heavy rain). If unit has been removed from original crate, cover with a tarpaulin during any preservation period.

Storage of Commissioned Equipment

- Reinstall original shipping brackets to protect equipment.
- When disconnecting power connections to control station and motors, plug all inlets with an appropriate fitting to keep water/moisture from entering. Do NOT leave any electrical connections open and exposed.
- Add anti-condensation packs to motor J-Boxes and control station.
- Install and seal all control station doors and J-Box Covers.

NOTE: Using Hercules Real Tuff Thread Sealant with Teflon (MSDS NS 5820 A.5.4) on plug threads helps to prevent leakage. (Refer to Figure 16.)



Figure 15
Amp Meter



Figure 16
Sealant Used on Plug Threads

DECOMMISSIONING PROCEDURES

WARNING



When decommissioning shaker, shut off and lock out power BEFORE removing guards (brackets, skirt, etc.). Follow all local and national electrical codes. Failure to comply could result in severe personal injury or property damage. Lockout of power MUST be done by a certified electrician.

- Wash unit and remove screens from skids.
- Disconnect flow line from feeder and main power lines from control panel.
- Attach shipping brackets to baskets and skid.
- Move or transport shaker via lifting points indicated on skid.

3.0 OPERATING INSTRUCTIONS

ADJUSTABLE PARAMETERS DURING NORMAL OPERATING CONDITIONS

Screen Selection

- Selection of screen mesh depends on a number of factors:
- flow rate, fluid condition, formation, rate of penetration (ROP), fluid type and number of shakers.
- Use the finest screen possible to ensure optimum performance to the relative screen life.

Flow Rate

- Adjust flow rate to maintain a constant pool level on all shakers used. The optimal fluid end point is 75% of screen surface.

Basket (Deck) Angle

- The basket deck angle is manually adjustable between -3 degrees and +3 degrees. (Refer to Figure 17.)

NOTE: Shut down of shaker before changing deck angle is NOT necessary.

ATTENTION

Do NOT use air/pneumatic ratchet or wrench to adjust deck angle jack.

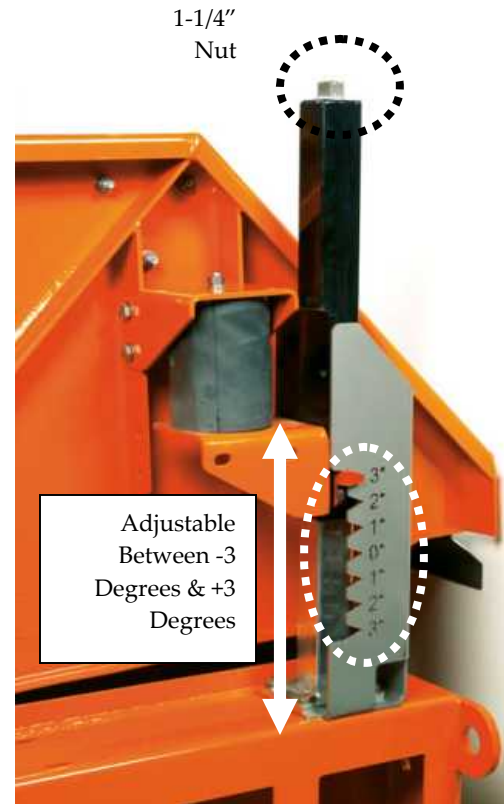

Figure 17
Basket (Deck Angle)

CHANGING BASKET (DECK) ANGLE

IMPORTANT: Do NOT adjust more than 2 degrees per side while changing deck angle.

- Use a manual ratchet, wrench or screen clamping wedge to adjust the 1-1/4" nut located on top of jack. Adjust each side to desired position. Set each side to the SAME angle.
- Locate manual jacks on discharge end of shaker and set basket at any angle between the highest and lowest angle.

NOTE: Lower angle settings result in longer screen life and wetter cuttings. Higher angle settings result in drier cuttings and increase fluid capacity.

- Reset fluid end point by adjusting basket angle or by careful selection of mesh size.

NOTE: Always operate shaker with lowest possible basket angle to meet capacity requirements. A steep incline results in screen overload and decreased screen life.

SHAKER SPEED

The shaker is designed to operate at 1,500 rpm (with 50Hz motor) or 1,800 rpm (with 60Hz motor) in both water and oil based mud.

Two (2) Motor Control Panels

- The two (2) motor control panel has START and STOP. This panel is used ONLY on linear motion shakers. (Refer to Figure 18.)

Three (3) Motor Control Panels

- The three (3) motor control panel has a selector switch for operation as either a linear or elliptical motion shaker.
- Switch between linear or balanced elliptical motion to change the motion of the shaker. (Refer to Figure 19.)

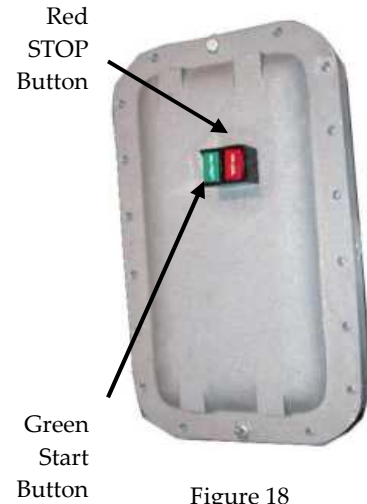

Figure 18
Two Motor Control Panel

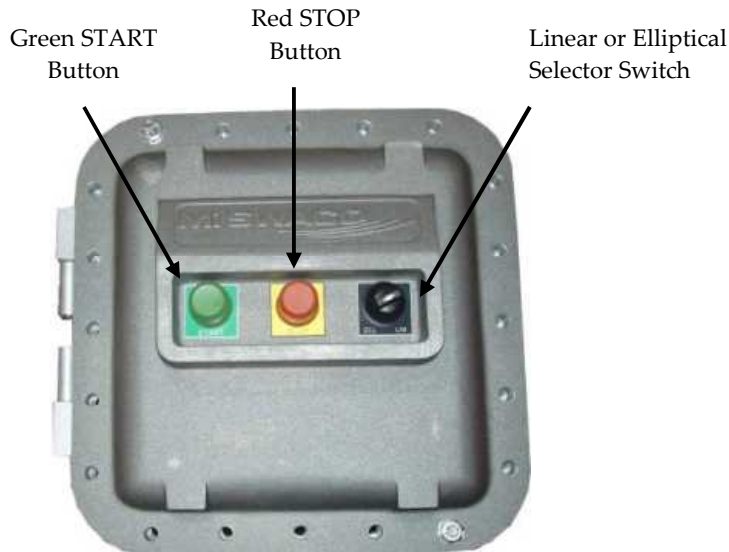

Figure 19
Three Motor Control Panel

ATTENTION

Unit shutdown is NOT necessary when switching between linear & elliptical motion.

EQUIPMENT START-UP

ATTENTION

Make sure all objects (such as tools) are clear from equipment BEFORE starting unit.

- Ensure screens are properly installed and firmly wedged into place. (Refer to Figure 20.)
- Wet screens with base fluid PRIOR to running drilling fluid.



Figure 20
Screens & Wedges Firmly In Place

- Ensure a gate is placed at any unused effluent stream outlet (of the skid), and desired outlet is unobstructed.
- Check all electrical connections. Turn unit control panel to LINEAR or ELLIPTICAL (if unit has a 3rd motor) depending on drilling parameters.
- Push START button on control panel to start shaker.
- Allow fluid to flow over shaker screens.

NOTE: Apply flow of fluid slowly at first to avoid flooding screens.

- Keep fluid end point at 75% coverage of the screening surface for optimal performance.



WARNING

Keep all guards in place at all times to avoid exposure to parts rotating at high speeds. While power is on, severe injury can occur if hands or feet reach inside unit.

CONTROLLED SHUTDOWN

- Close off flow to feeder.
- Continue to run unit until drilling fluid already on screens is processed.
- Thoroughly clean baskets and screens using appropriate base fluid.
- Push STOP button on the start/stop station.

CAUTION

Follow ALL safety instructions. Use PPE equipment when using steam or pressure equipment.

NOTE: Do NOT use a squeegee or any other foreign object to clean screens.

NOTE: If unit is out of use for long periods, remove; clean thoroughly; dry; and, either re-box or store all screens in a safe, dry area.

SCREEN HANDLING

Screen Installation Procedures

Mongoose units have four (4) pre-tensioned screens and ten (10) wedges per shaker basket (with two spares on the cable tower). The Meerkat units have three (3) pre-tensioned screens and eight (8) wedges per shaker basket. Once screens are placed on the screen bed, wedges are driven between each screen edge and support bars on shaker sidewalls. The screen bed is slightly crowned at the center causing screen frames to bow when wedges are forced in place. This prevents screens from “whipping” up and down during shaker operation.

CHANGING/INSTALLING SCREENS

ATTENTION

Wash down screen area
PRIOR to installing new screens.

- Stop flow of drilling fluid to shaker. While shaker is running, wash down screens. Clean all cuttings and solids build up around inside of deck and wedges.
- Shut down shaker.

WARNING



Perform lockout/tagout procedures to isolate rig power supply.

ATTENTION

Use a rubber mallet to avoid damage to wedges.

- Each screen is secured in place by two (2) wedges (one per side). A rubber mallet is required to remove wedges. A rubber mallet blow to end or to top handle section can remove wedges.

NOTE: Due to the position of the motor tube on the Meerkat units, an extra screen wedge (supplied with shaker) can be used as an extension with the rubber mallet to assist in the removal of the middle screen. Turning the extra wedge on its side provides additional working space enabling the operator to avoid possible pinch points. (Refer to Figure 21.)

- Remove screen panel. Screen panels are removed and installed one at a time.

NOTE: Repeat the following steps for each additional screen panel.

- Wedges for the second screen from the feed end are REVERSED for easier installation.
- Wash down screen bed and gasket prior to installing new screens. (Refer to Figure 22.)

ATTENTION

Replace any deck gaskets if worn, cracked or hardened.

- Lay new screen into shaker deck. Position one wedge between screen edge and support bar on shaker side wall. (Refer to Figure 23.) Position other wedge on opposite side in same manner and hammer tight.

ATTENTION

Both wedges must be in position PRIOR to hammering them tight. Failure to do so will prevent the second wedge from being started.

- Wet down new screens with base fluid PRIOR to use of drilling fluids.



Figure 21
Meerkat Screen Removal



Figure 22
Screen Deck Gaskets



Figure 23
Wedge Positioned
Between Screen
Surface & Support Bar

Screen Washing & Blinding

CAUTION

Follow all safety instructions. Use PPE equipment when cleaning unit.

ATTENTION

NEVER use a wire or stiff fiber brush on screens. Wash screens with appropriate medium BEFORE shaker unit is shut down to avoid plugging or blinding meshes by dried solids.

SCREENS PLUGGED WITH SOLIDS

Wash screens from back side using base fluid with screens REMOVED from shaker.

- Change screens to a finer mesh.

Screen Storage

ATTENTION

Avoid mechanical damage. Always wash screens PRIOR to storing them.

- Store screens in original cardboard packaging to protect screen mesh.
- Horizontal or vertical stacking is permissible.

SECTION 4.0 PREVENTATIVE MAINTENANCE

SAFETY RELATED MAINTENANCE PROCEDURES

WARNING



BEFORE starting any parts replacement procedure or general maintenance, initiate a controlled shutdown. Lockout/tag out unit. Have a certified electrician ensure power supplies are isolated BEFORE performing any maintenance on unit.

- Clean all parts and work area.
- Block up and secure heavy parts BEFORE working beneath unit or parts.
- Where heavy lifting is involved, always seek assistance.
- Remove all screens BEFORE any work is carried out on shaker.
- Ensure all tools, old parts, nuts, bolts, washers, etc. are removed BEFORE restarting unit after maintenance.
- Do NOT weld on any part of basket assembly.
- Use only qualified personnel to perform maintenance.
- Visually examine unit for signs of wear and/or damage. Repair/replace as necessary.
- Clean unit removing any solids build-up.
- Perform audible checks, investigating as necessary.

MOTOR MAINTENANCE

NOTE: Refer to the “Martin Motomagnetic Operator’s Manual” in the Installation, Operation & Maintenance (IOM) manual for detailed maintenance to the vibrator. Installation of vibrator should be done by a certified electrician.

Lubricate Motor Bearings (Every 3000 Operational Hours)

ATTENTION

Only use Kluber Isolflex Topas NB 52 lubricant for bearings.
Failure to do so will void the motor warranty.

- Remove plugs (one for each bearing) and insert an 1/8” NPT Zerk grease fitting. (Refer to Figure 24.)
- Pump .882 ounces (25 g) of lubricant into each bearing for normal, bearing surface temperatures below 195°F (91°C). Do NOT over grease.



Figure 24
Grease Fittings

Motor Bolt Torque (Refer to Figure 25.)

WARNING

NEVER reuse motor installation hardware (ie. bolts, washers and nuts). Always use new bolts. Check and re-torque new bolts after first four (4) hours of run time.

NOTE: There are a total of four (4) motor bolts per each motor which are torqued to the proper requirements when shipped from factory.

- Using a 30 mm socket (3/4” drive) with a 200 mm (8”) extension apply a torque of 435 N-m (320 ft.-lb.) to all LARGE motor mounting bolts.
- Using a 24 mm socket (1/2” drive) with a 200 mm (8”) extension apply a torque of 245 N-m (180 ft.-lb.) to all SMALL motor mounting bolts.
- Verify and document motor bolt torque every 672 hours or 1 time per month of operation for bolts already in use in the field.



Figure 25
Motor Bolts – Four Per Motor

Motor - Electrical Connections (Isolators)

Any time motor leads are changed or cable is replaced, ensure black neoprene vibration isolators are installed properly BEFORE operating unit.

CAUTION

Isolators are removable, but should always be in place when unit is in use to protect electrical connections in the motor. Failure to do so causes premature wiring failure or mounting post breakage.

- Install the thin isolator first. (Refer to Figure 26.)
- Connect motor leads to the correct terminals.
- Place the thick isolator on top of motor leads. (Refer to Figure 27.)
- Place cover on and tighten bolts.

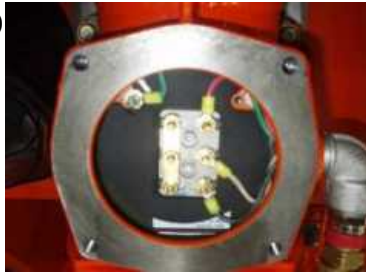

Figure 26
Thin Isolator - Motor Leads
Showing



Figure 27
Thick Isolator - Motor Leads
Not Showing

ISOLATION SPRINGS

NOTE: There are four (4) isolation springs per basket. (Refer to Figure 28.)

Inspection for Fatigue & Replacement

- Check each spring for signs of fatigue or fracture every 3 months, or if shaker basket is tilting side-to-side and cuttings are running to one side of the basket.

ATTENTION

Springs are covered with a protective black nitrile “boot” serving as a safety precaution against bare springs acting as a possible pinch-point. (Refer to Figure 28.)



Figure 28
Spring Enclosed in Nitrile Boot

- Check for spring fatigue by setting basket level and measure the height of each spring.
- The front two springs should be same height, and the back two springs should be same height.

NOTE: Height of back springs may differ from height of front springs.

Replacing Springs

- Remove all weight from springs BEFORE changing them.
- Lift basket (with proper lifting device) to remove weight from springs.
- The spring slides out for replacement.

GREASING DECK ADJUSTMENT JACK

The deck angle adjustment jacks have a grease fitting located on the discharge side of the jack. (Refer to Figure 29.)

Once a month, apply 10 shots of a multi-purpose grease into grease fitting.

Run deck angle adjustment up and down twice to allow grease penetration to jack inner screw.

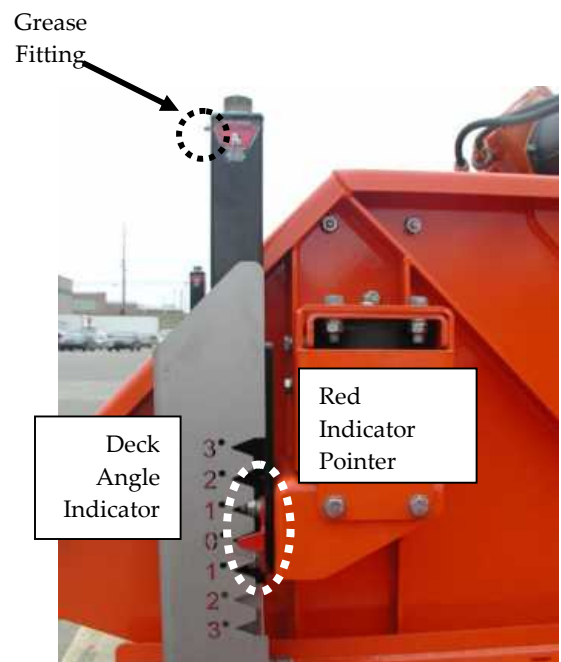

Figure 29
Grease Fitting

RECOMMENDED PREVENTATIVE MAINTENANCE SCHEDULE

TABLE 3. RECOMMENDED PREVENTATIVE MAINTENANCE SCHEDULE

Item	Task	Interval	Item	Task	Interval
Electrical Cables	Check for wear and damage.	Weekly	Gasket Grommets	Check for holding.	Monthly
Screen Gaskets	Check for cracks.	Monthly	Flow Control Gates	Check for free operation.	Monthly
Deck Adjustment System	Check for full up and down travel.	Monthly	Nuts and Bolts	Check for tightness.	Monthly
Support Springs	Check for uneven compression.	Monthly	Motor Bolts	Verify proper torque.	Monthly
Screen Hold Down Bar	Check screws for tightness.	Monthly	Deck Adjustment System	Grease jack fitting.	Monthly

NOTE: Time intervals above assume continuous shaker running operation.

SECTION 5.0 TROUBLESHOOTING

Symptom	Probable Cause	Corrective Action
Screen wedge comes loose.	Wedge not properly installed.	Ensure wedge is fully engaged.
	Solids under screen or wedge.	
Solids are migrating to one side of the basket or not discharging properly.	One vibrator motor not running.	Check vibrator motor and control panel.
	One vibrator rotating in wrong direction.	Reverse rotation.
	Unit not level.	Level unit.
Shaker makes unusual loud noises.	Wedge(s) loose.	Check and reinstall wedges.
	Vibrator bearings worn.	Replace motor.
	Improper clearance between basket and skid.	Determine and fix cause of interference.
	Loose fasteners or hardware.	Locate and tighten.
Bypass stuck.	Caked mud on unit.	Clean unit.
Mud builds up on screen or too much spills over discharge	Incorrect deck angle.	Adjust deck angle.
	Screen mesh too fine.	Change to a coarser mesh screen.
Mud builds up at back edge of screen.	Third motor not rotating in correct direction.	Reverse rotation.
	Screen cloth tension loose on screen.	Replace screen panel.
Discharge gate will not fully close.	Clogged with mud.	Clean out gate with water.
	Gate bent.	Straighten gate.
	Gate holder bent.	Straighten gate holder.
Vibrator overheating (70° over ambient temperature.)	Bearing out of grease	Service bearings.
	Bearing worn out.	Replace motor.
CAUTION		
The following actions MUST be performed by a certified electrician.		
Vibrators fail to rotate.	Main supply down.	Check supply to control box.
		Ensure isolator is ON.
		Check supply fuses.
One vibrator fails to rotate.	Damaged wiring.	Check wiring.
	Damaged vibrator.	Check vibrator.
	Damaged thermal overload.	Check thermal overload.
Shaker stops.	Controls tripped.	Check circuit breakers and thermal overloads within control panel.

SECTION 6.0 MAINTENANCE PROCEDURES

SCREEN GASKET REPLACEMENT

WARNING



Initiate shut down procedure. Disconnect and lockout/tagout power to control panel.

ATTENTION

Failure to replace worn or hardened screen gaskets can result in damage to screen bed.

- Wash and remove all screens from shaker.

NOTE: Periodic cleaning of shaker keeps the unit running at top efficiency. Wash screens each time shaker is shut down.

- Wash deck area thoroughly. Ensure screen bed is clean.
- Remove hardware and then remove rubber screen gaskets with bars.

NOTE: Replace screen deck rubber screen gaskets when signs of cracking or hardening are present.

Grommet Replacement (Figure 30)

NOTE: Replace plastic grommets when rubber screen gasket is replaced.

- Place grommet in the rectangular slot and press down to lock into position.
- Thoroughly clean screen deck.
- Lay new screen gasket into place and install screen bar on top of gasket.

NOTE: If necessary, align grommets with screw holes in screen bar using a small screwdriver.

- Tighten all screws with a No. 2 bit. Ensure lip of gasket is tight to screen bar.

Press down to lock grommet into place.

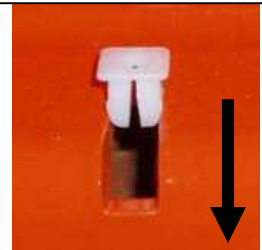

Figure 30
Fitting Grommet
in Rectangular
Slot

CAUTION

Do NOT over tighten. Grommets may pull out if excess torque is applied.

ISOLATION SPRING REPLACEMENT PROCEDURES

NOTE: Replacing the four (4) main basket spring every twelve months is recommended. If one spring appears more compressed than the others, replace right away. Remove all weight from springs BEFORE changing them.

CAUTION

Lift basket (with proper lifting device) to remove weight from springs.

Once basket is lifted, remove top and bottom bolts securing spring spool. (Refer to Figure 31.) Springs slide out for replacement.



Figure 31
Top Spring Bolt

VIBRATOR REMOVAL & INSTALLATION

CAUTION

Follow all safety instructions. Use of PPE is required during removal and installation of vibrators.

WARNING



Ensure power to control panel is switched OFF and lockout/tagout procedures are followed. These actions must be performed by a certified electrician.

NOTE: Document wire colors to specific terminals in motor junction box BEFORE disconnecting.

Disconnecting Cable Gland (Figure 32)

- Disconnect terminals from motors.
- Loosen and slide nut located on cable gland over motor cable.
- Loosen cable gland.
- Carefully pull all wires in motor junction box out avoiding damage to wire connectors and wires.
- When motor cable is removed from junction box, remove all fittings attaching the cable gland to the motor.

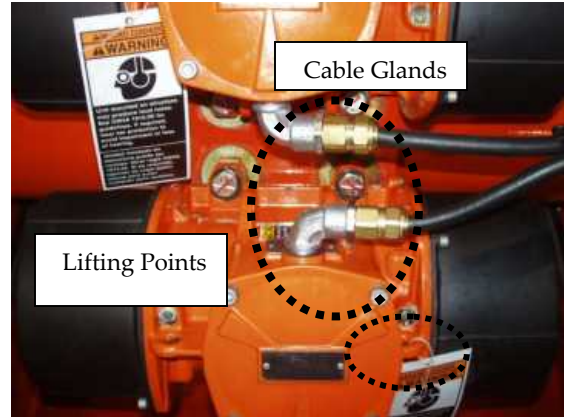

Lifting & Moving Vibrators

WARNING



Ensure power to control panel is switched OFF and locked out. Only a qualified electrician can perform any electrical connections or disassemble electrical equipment with this unit.

- Hook proper lifting device to motor lifting points.
- Remove motor bolts and hardware.

NOTE: Note motor wire inlet location and direction on junction box BEFORE removing motor.

- Remove motor.

CAUTION

Motors are heavy. Large motor is 98 kg (216 lbs.). Small motor is 44 kg (96 lbs.). Apply a small amount of tension to lifting device to keep motors from falling during motor bolt removal.

Installing/Replacing Motor

CAUTION

Ensure vibrator mounting area is absolutely clean and not damaged BEFORE installing a vibrator.

- Clean bottom of vibrator feet. (Refer to Figure 33.)
- Ensure motor plate is also clean.



Figure 33
Bottom View of Motor

ATTENTION

NEVER grind the motor mounting surface or the motor plate. Grinding will render the equipment inoperable. NEVER re-use motor installation hardware. Always use new bolts. Check and re-torque new bolts after first four (4) hours of run time.

- Lift vibrator in place using proper lifting equipment.
- Align motor wire inlet location in the same spot as before. Install new motor mounting hardware.

ATTENTION

Note orientation of motor bolts. Head of bolt is on the OUTSIDE of the motor plate. The nut is on the INSIDE of the motor plate.

- Hand-tighten all bolts.
- Apply initial torque of 160 ft./lbs. (217 Nm) to all large motor bolts and 85 ft./lbs. (115 Nm) to all small motor bolts. Apply a final torque of 320 ft./lbs. (434 Nm) to all large motor bolts and 180 ft./lbs. (244 Nm) to all small motor bolts.
- Reinstall all fittings into the motor wire inlet in the same order as they were removed. Feed wires into fittings. Ensure wires are not damaged or twisted inside the elbow.
- Connect electric cable to vibrator using appropriate glands.
- Tighten nut, then cord grip onto cable gland.
- Reconnect wires to correct terminals. Reinstall junction box cover and tighten bolts.
- Re-torque motor mounting bolts after running motors for 4 hours.
- If the vibrator has adjustable eccentric weights, fix counter-weights at a setting of 100%.
- Recheck motor rotation.

NOTE: Large motors (one piece weights) are fixed at 100%. Ensure smaller motors are pre-set at 100%.

ATTENTION



Do NOT run shakers with one or more motor mounting bolts missing or improperly torqued. Failure to follow these guidelines can result in motor malfunction causing extensive damage or injury.

CABLE GLAND ASSEMBLY INSTRUCTIONS

Cable Gland Components (Figure 34)

- A – Entry Item
- B – Compound Tube
- C – Armor Cone
- D – Armor Sleeve
- E – Gland Body
- F – Back Nut
- G – Epoxy Compound
(Store in plastic bag.)



Figure 34
Cable Gland Components

Cable Gland Assembly Steps

- Determine conductor length required for equipment geometry.
- Remove outer jacket of motor cable to expose bronze armor braid.
- Cut bronze armor braid length to $\frac{5}{8}$ ".
- Remove inner jacket and fillers to expose conductors.
- Cut inner jacket length to $\frac{5}{8}$ ". (Refer to Figure 35.)
- Install entry item into motor J-Box entry and/or control panel entry and tighten.
- Slide back nut, gland body and armor sleeve on motor cable.
- Insert armor cone in entry item.
- Feed conductors through entry item and armor cone.
- Hold bronze armor braid located between armor cone and armor sleeve.
- Insert armor cone and sleeve assembly fully into entry item and hold.
- Slide gland body to entry item tightening and crimping armor between armor cone and sleeve. (Refer to Figure 36.)
- Loosen gland body and slide away from entry item.
- Remove cable from entry item.
- Thoroughly mix the two part epoxy compound in equal proportions to a uniform color and pliable consistency.

NOTE: Plastic gloves are provided for protection while handling the epoxy compound.

- Separate conductors and pack each in the mixed epoxy compound until all voids between conductors and armor cone and sleeve assembly are filled. (Refer to Figure 37.)
- Bring conductors back together and form a packing 1- $\frac{1}{4}$ " long and sufficient in size to fill compound tube. (Refer to Figure 38.)
- Slide compound tube on armor cone until it seats. Ensure compound tube is completely filled. (Refer to Figure 37.)
- Remove any excess epoxy compound that may ooze out and also from all external faces.
- Do not allow epoxy compound to exceed end of compound tube. Ensure epoxy compound is found at all points between conductors and compound tube.
- Insert conductors into entry sliding cable gland assembly into position. Tighten gland body to the entry item.
- Tighten back nut to gland body.

NOTE: Leave assembly undisturbed for 24 hours allowing epoxy compound to set.



Figure 35
Armor Braid with Inner Jacket Cut to Size



Figure 34
Armor Braid Locked to Gland Assembly



Figure 36
Epoxy Compound Packed Around

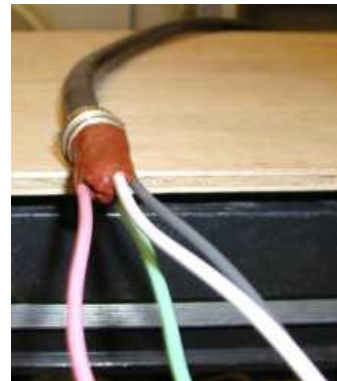

Figure 37
Epoxy Compound Formed to Fill Compound Tube with Conductors Back Together



Figure 38
Compound Tube Filled with Epoxy Compound

ELEVATOR JACK REPLACEMENT

CAUTION

Use proper lifting guidelines.

WARNING



BEFORE starting any parts replacement procedure or general maintenance, initiate a controlled shutdown. Lockout/tag out unit.



Figure 39
Overhead View of Hardware
Base

- Raise basket enough to relieve weight off of spring and remove spring.
- Loosen and remove 12 mm hardware at base of elevator jack with a 19 mm wrench or socket with extensions. (Refer to Figure 39.) Remove spring support bracket and pointer from elevator jack.
- Reinstall spring support and pointer on new elevator jack in the same previous position. Mount new elevator jack on indicator plate. Install 12 mm hardware and hand tighten.
- Ensure pointer does not interfere with indicator plate when jack elevates. A one quarter (1/4") gap is preferred.
- Inspect and reinstall spring. When spring is lowered back in position, make sure isolation washer (rubber washer between spring, basket and skid) is in place.

SHAKER WASH DOWN PROCEDURES

CAUTION

Follow all safety instructions. Use of PPE is required during shaker wash down.

Normal Daily Wash Down Procedures

- Use base fluid and thoroughly hose down entire unit with screens in place and shaker running to completely remove all solids from screen surface.
- When unit is clean, shut off power and remove all screens and set them aside. Continue washing shaker.
- Clean screen bed area extremely well ensuring seal area is free of drilling fluid that can cause bypass around screen frame later.
- Wash screens to remove sticky solids.

NOTE: Do NOT use a pressure washer which can damage fine mesh screens.

Wash Down After Circulation of Completion Fluids

CAUTION

Completion fluids typically contain a higher amount of chlorides and are usually highly corrosive. Therefore, it is extremely important that an extensive wash down is carried out after circulation of completion fluids is finished.

- Follow the “Normal Daily Wash Down” procedures listed previously.
- Lift shaker basket to its highest uphill angle and thoroughly wash interior of basket.

NOTE: There should be no screens in the basket

- Wash screens separately.

SURFACE CORROSION REMOVAL – STAINLESS STEEL COMPONENTS

Cleaning Specifications

See detailed methods “A” and “B” below. The method chosen greatly depends on environmental conditions.

Method A		Method B	
Step No.	Description	Step No.	Description
1	Apply thick layer of Derustit SS-3 or Derustit Beizpaste 4020 with a brush using a plastic container.	1	Apply ZEP Stainless Steel cleaner to effected areas per manufacturer recommendations.
2	Allow paste to set for 15 minutes on surface.	2	Use stainless steel scouring pads to remove corrosion and rinse area thoroughly per manufacturer recommendations Repeat process if necessary.
3	Rinse area thoroughly with water using a 2000-3000 psi pressure washer. NOTE: If pressure washer is not available, normal line pressure is sufficient with use of a stainless steel wire brush. Repeat process if necessary.	3	Once all surface corrosion is removed, wipe areas that were affected with a rag and surface cleaner (paint thinner is recommended) to remove oil, dirt and debris from areas. Let areas dry for about 5-10 minutes.
4	Once all surface corrosion is removed, wipe areas that were affected with a rag and surface cleaner (paint thinner is recommended) to remove oil, dirt and debris from areas. Let areas dry for about 5-10 minutes.	4	Apply first coat of VpCI®-383 (or equivalent). Apply by spray, brush, roll or dipping.)
5	Apply first coat of VpCI®-383 (or equivalent). Apply by spray, brush, roll or dipping.)	5	Apply second coat of VpCI®-383. Allow second coat to dry for 15 minutes.
6	Apply second coat of VpCI®-383. Allow second coat to dry for 15 minutes.		

NOTE: VpCI®-383 or VpCI®-386 water based protective coating is recommended to protect surface once corrosion is removed.

ADJUSTING BRAKE FOR ELLIPTICAL (SMALL) MOTOR

WARNING



BEFORE starting any parts replacement procedure or general maintenance, initiate a controlled shutdown. Lockout/tag out unit.

WARNING



Keep all guards in place at all times to avoid exposure to parts rotating at high speeds. When power is on, severe injury can occur if hands or feet reach inside unit.

- Remove motor-weight cover from the third motor facing the control panel and open electrical enclosure door.
- Locate contact timer control in the enclosure. (Refer to Figure 40.)

NOTE: Timer may appear different than the one shown.



Contact Timer Main Motors (Linear) Third Motor (Elliptical)

Figure 40
Contact Timer

- Turn shaker ON in the linear motion setting.
- Contactors for the two main motors will engage and motors will begin running.
- Change motion control switch to elliptical setting. (Refer to Figure 41.) Contactor for third motor will engage, starting third motor.
- STOP rotation of third motor by changing the motion control switch to linear setting.

NOTE: The third contactor disengages while the fourth contactor engages. This reverses polarity of the third motor which in turn reverses the motor rotation. The reversing circuit is controlled by the contact timer control.



Figure 41
Close-Up of Control Panel

- When switching from elliptical to linear motion, watch third motor weight as the reversing circuit is engaged.
- Set contact timer to stop third motor completely.

NOTE: A timer setting too low does not fully stop the motor. A timer setting too long causes motor to begin running in the opposite direction.

- When timer is properly set, shut OFF unit. Close electrical enclosure and reinstall motor weight cover on third motor.

SECTION 7.0 RECOMMENDED SPARE PARTS LIST (RSPL)

**RIG CRITICAL
RECOMMENDED
SPARE PARTS LIST**

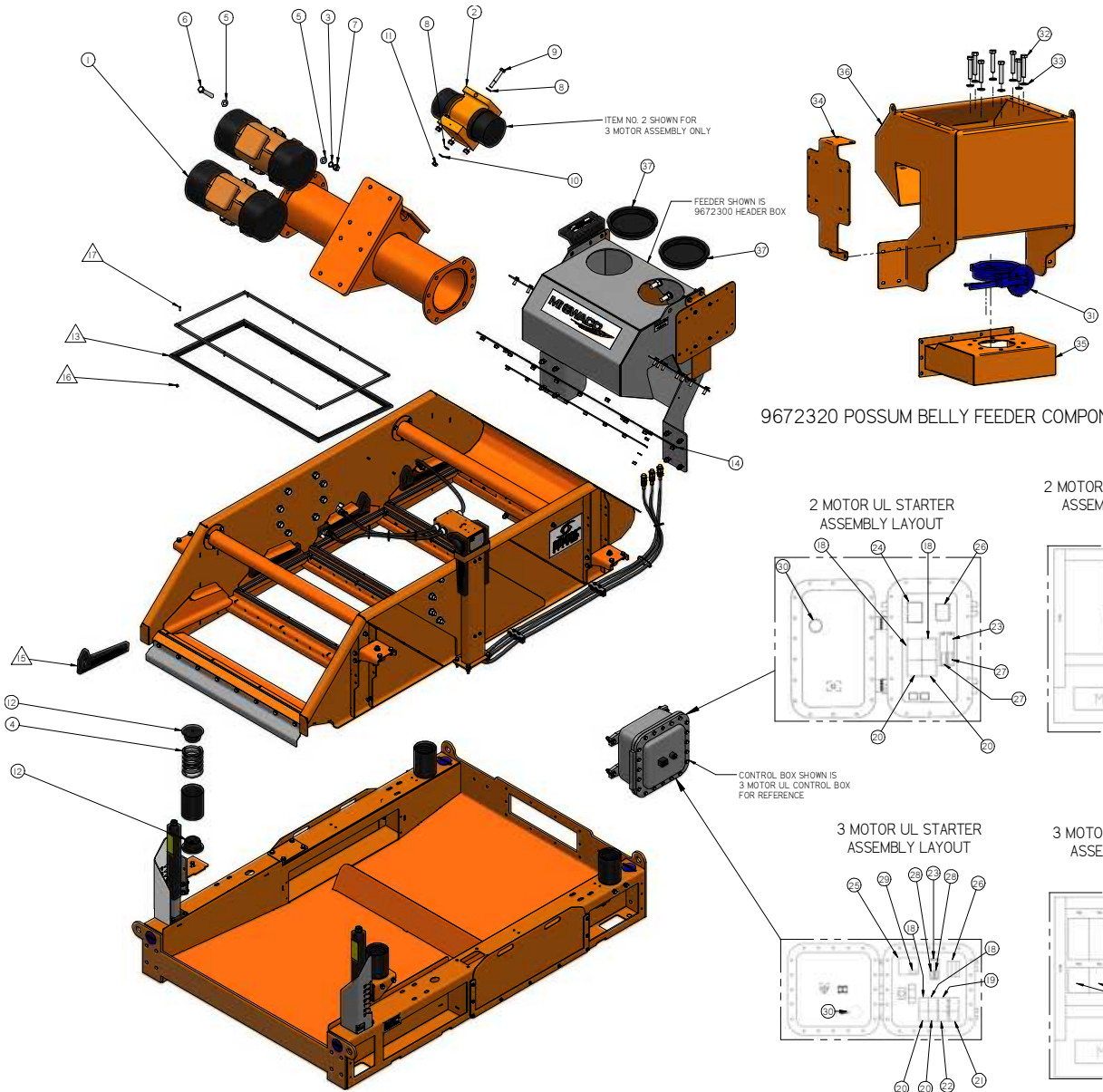

9672320 POSSUM BELLY FEEDER COMPONENTS

ISO VIEW 9672300

2 MOTOR UL STARTER ASSEMBLY LAYOUT

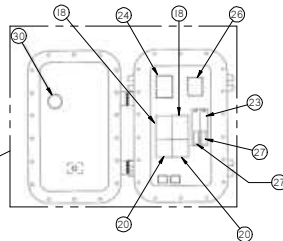

2 MOTOR ATEX STARTER ASSEMBLY LAYOUT

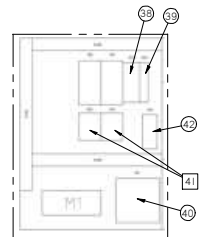

3 MOTOR UL STARTER ASSEMBLY LAYOUT

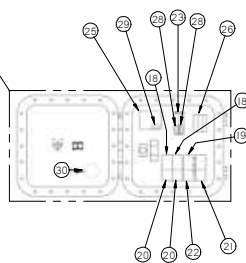

3 MOTOR ATEX STARTER ASSEMBLY LAYOUT

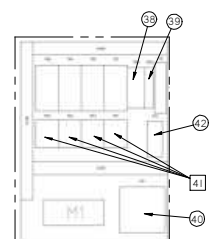

TABLE 4. RIG CRITICAL RECOMMENDED SPARE PARTS LIST

Item Number	Part Number	Description	Qty.
1	EM3C00111	Motor 2 Hp 220-240/440-480V, One Piece Weight 60/3/1800	2
	EM3C00110	Motor 1.75 Hp 220-240/380-415V, One Piece Weight 50/3/1500	
	EM3C00137	Motor 2 Hp 575-600V, One Piece Weight 60/3/1800	
2	6912002	Motor 230/460V 0.6 Hp 60 Hz, XP	1
	6912065	Motor 230/460V 0.6 Hp 60 Hz, XP, 35 Frame	
	6905003	Motor 230/380V 0.5 Hp 50 Hz, XP	
	6912066	Motor 230/380V 0.5 Hp 50 Hz, XP, 35 Frame	
	EM3C00038	Motor 575-600V 0.6 Hp 60 Hz, XP	
	6912067	Motor 575-600V 0.6 Hp 60 Hz, XP, 35 Frame	
3	05-244	Lock Washer Schnorr M20 Martin #513014	8
4	9360007	Spring Coil 7"	4
5	1345015	Washer Flat Blackened F436 ¾" x 1-15/32 OD Hardened	16
6	1407169	Screw Hex Head Plated M20-1.5 x 120 mm LG Grade 10.9	8
7	1305055	Nut Hex Plated M20 x 1.5, Grade 10.9 Yellow Chromate Plated	8
8	1345123	Washer Flat Blackened F436 11/16 ID x 1-3/16 OD x 108" Thick Hardened	8
9	1407144	Screw Hex Head Plated M16-1.5 x 100 mm LG Grade 10.9	4
10	05-248	Lock Washer Schnorr M16	4
11	1305040	Nut Hex Plated M16-1.5, Yellow Chromate Plated, Grade 10.9	4
12	BM6K80290	Spring Spool	8
13	5837001	Gasket, Mongoose Flat Panel Screen	4 (3)*
14	5873004	Mongoose Skirt, Feed End	1
	MK3K02102	Meerkat Skirt, Feed End	
15	5895001	Wedge, Mongoose Screen Clamping	8 (6)*
16	07-415	Grommet Screw .273 Square Panel Hole	32 (24)*
17	1441471	#8 Flat Head Sheet Metal Screw with Square Drive	32 (24)*
18	7150017	Contact, Non-Reversing	2
19	7150018	Contact, Reversing	1
20	7152008	Relay, Thermal Overload (2.4-4.0)	2
21	7152009	Relay, Thermal Overload (6.0-10.0)	1
22	7152007	Relay, Thermal Overload (1.0-1.6)	1
23	7519002	Fuse Block (Rejection)	1
24	7725001	Transformer-380V	1
	7717001	Transformer-480V	
	790019	Transformer-575V	
25	7790018	Transformer-380V	1
	7790017	Transformer-460V	
	7790019	Transformer-575V	
26	7150014	Block Power Distribution	1
27	7518026	Fuses	2
28	7518020	Fuse Gould Shawnut ATMRI	2
29	7518022	Fuse Gould Shawnut OTM3	1
30	8265105	Emitter Plastic VCI-105	1
31	5641350	Valve Butterfly 8" Wafer Body with Handle	1
32	04-1577	HHCS M20 x 110 Metric 304 SS Full Threads	8
33	05-296	Flat Washer M20 Metric 304 SS	8
34	9672309	Control Mounting Plate Possum Belly	1
35	9672165	Bypass Weldment, Possum Belly Mongoose	1
36	9672162	Possum Belly Weldment Mongoose	1
37	S48B00829	10" Inspection Cover	2
38	7518370	Fuse 1 Amp AM Weber #IW 1422001	3
39	7518371	Fuse 4 Amp GG Weber #IW 1421004	2
40	7717006	Transformer 400/115V 63VA ATEX Control Panel	1
41	9320028	Contact 110V 50/60 Hz Siemens #3RT10 16-1AF01	4 (2)**
42	7116101	Relay 4 PDT 110V OMRON MY4	1

*Items in parenthesis are for Meerkat Units.

** Item is a 2 motor component

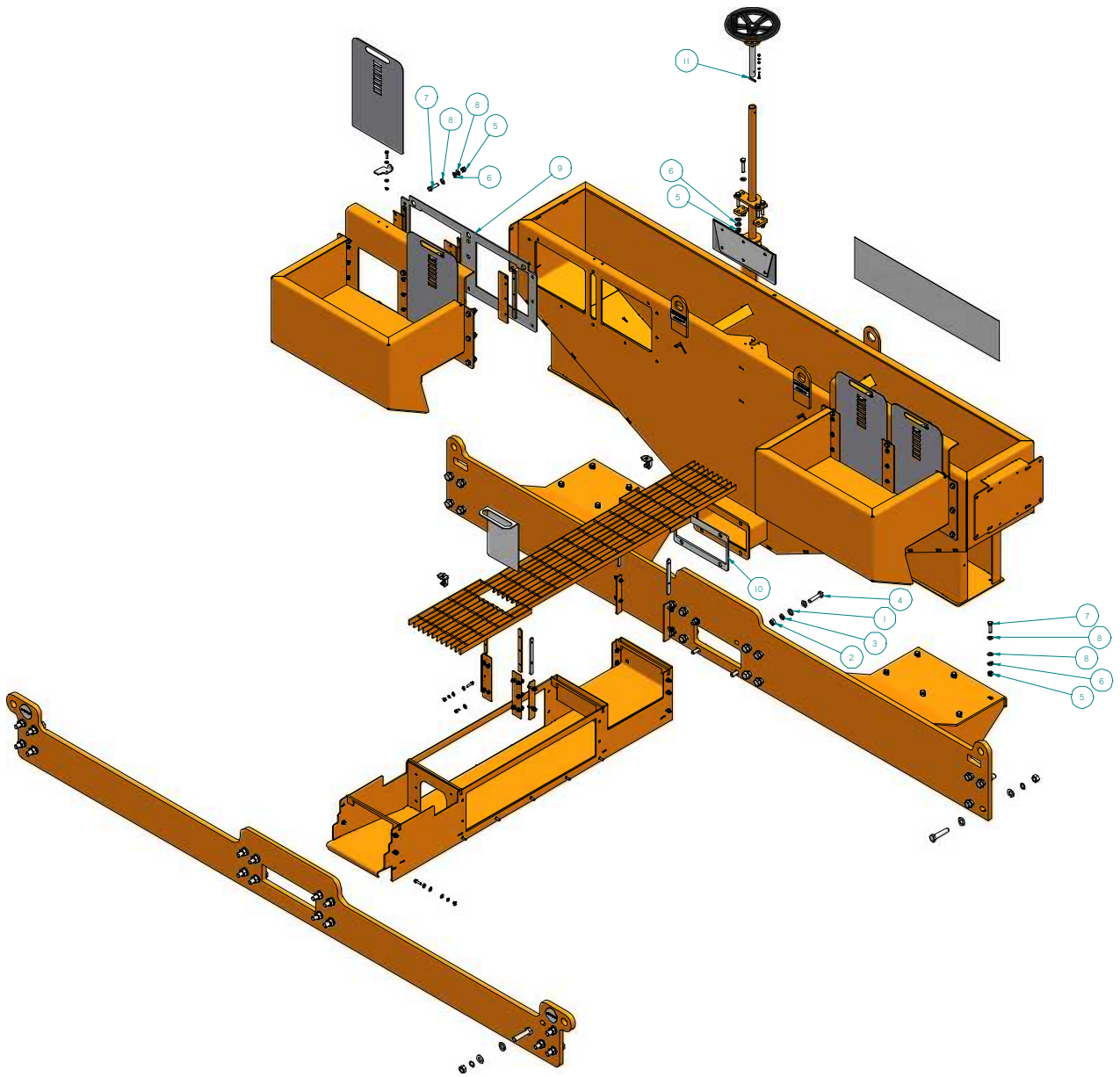

TABLE 4. RIG CRITICAL RECOMMENDED SPARE PARTS LIST FOR DUAL SHAKERS

Item Number	Part Number	Description	Qty.
1	05-289	Flat Washer M16	6
2	03-287	Hex Nut M16	2
3	05-272	Split Lock Washer M16 Regular	2
4	04-1107	HHCS M16 x 70 mm	4
5	03-415	Hex Nut M12	40
6	05-306	Split Lock Washer M12 Regular	40
7	04-1270	HHCS M12 x 45 mm LG	36
8	05-305	Flat Washer M12 Narrow	80
9	3914037	Gasket, Feeder Box Common Possum Belly	2
10	3914036	Gasket, Possum Belly Transition Dual Shaker	1
11	06-247	Roll Pin ¼ Diameter x 1.50 LG	1

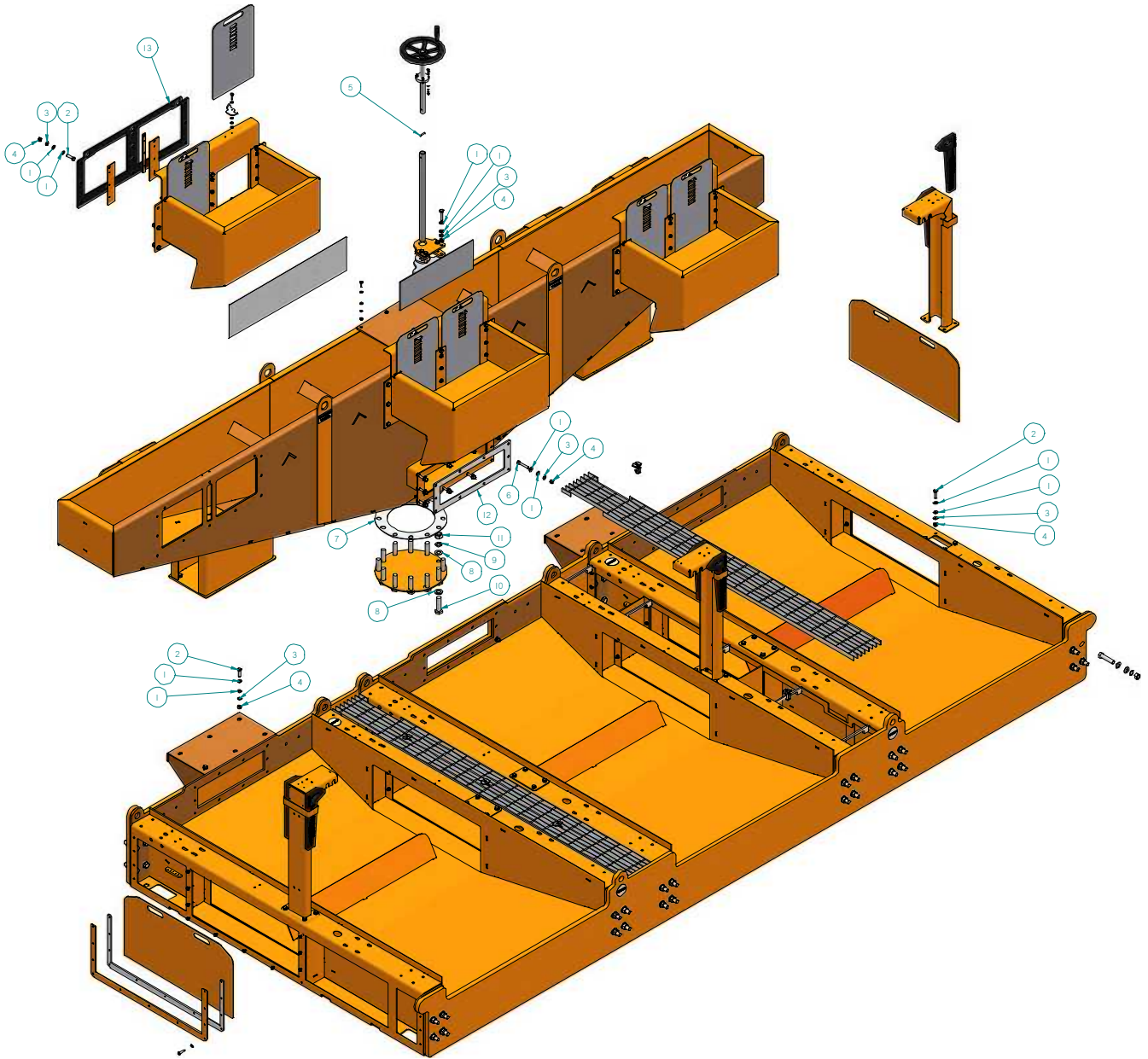

TABLE 4. RIG CRITICAL RECOMMENDED SPARE PARTS LIST FOR TRIPLE SHAKERS

Item Number	Part Number	Description	Qty.
1	05-305	Flat Washer M12 Narrow	172
2	04-1270	HHCS M12 x 45 mm LG	72
3	05-306	Split Lock Washer M12 Regular	86
4	03-415	Hex Nut M12	86
5	06-247	Roll Pin ¼ Diameter x 1.50 LG	1
6	04-1509	HHCS M12 x 70 mm LG with Full Threads	10
7	3916067	Gasket, Full Face ANSI Flange, 150 lbs., 10"	1
8	05-308	Flat Washer M24 Regular	24
9	05-309	Split Lock Washer M24	12
10	1493003	HHCS M24-3.0 x 90 mm, Yellow Chromate Plated	12
11	03-412	Hex Nut M24	12
12	3914035	Gasket, Transition Bypass Possum Belly	1
13	3914037	Gasket, Feeder Box Common Possum Belly	3

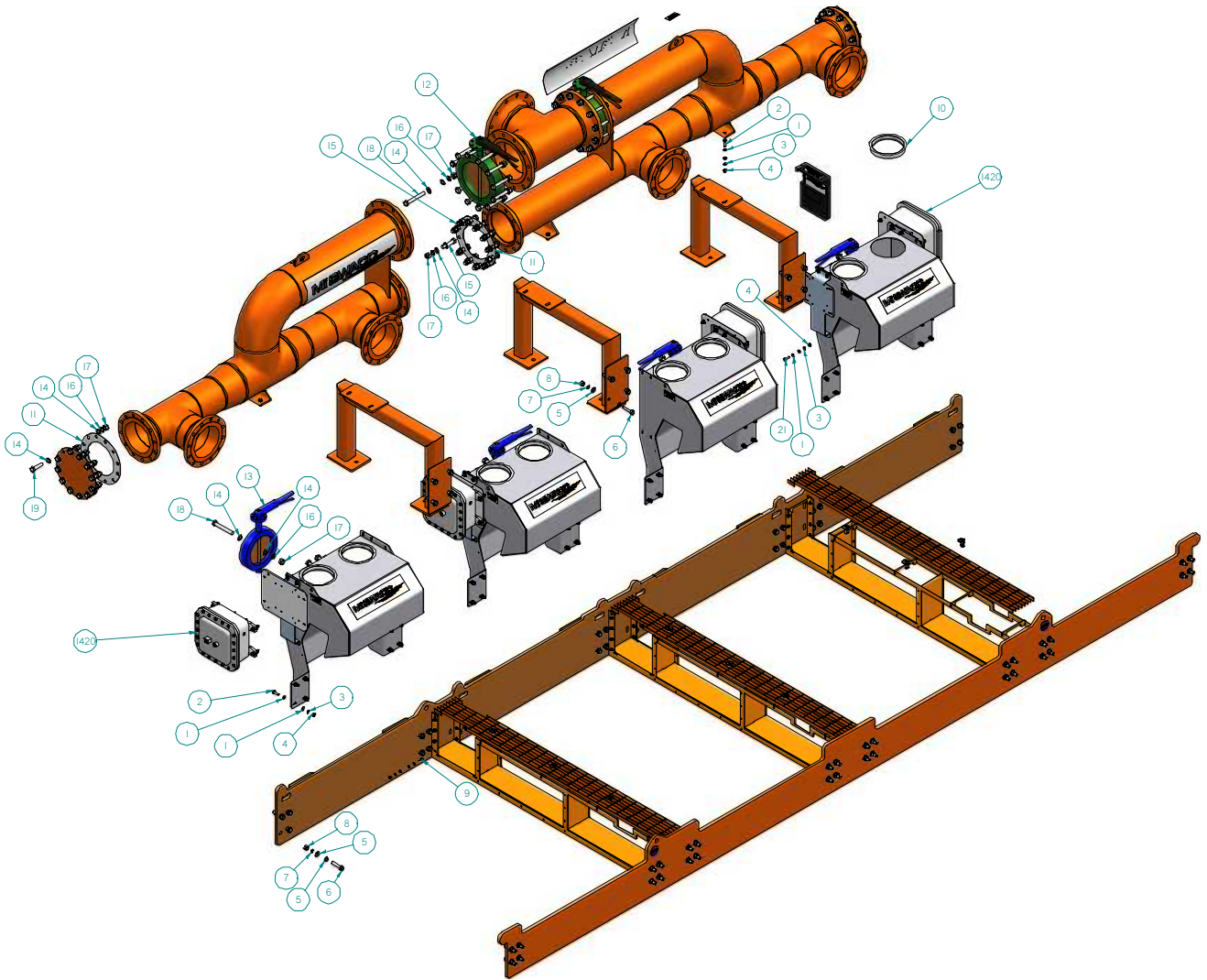

TABLE 4. RIG CRITICAL RECOMMENDED SPARE PARTS LIST FOR QUAD SHAKERS

Item Number	Part Number	Description	Qty.
1	05-281	Flat Washer M12 Narrow	180
2	04-1726	HHCS M12 x 45 mm LG	86
3	05-382	Split Lock Washer M12 Regular	90
4	03-230	Hex Nut M12	90
5	05-294	Flat Washer M20	152
6	04-1684	HHCS M20-2.5 x 90 mm LG, Grade 10.9, Yellow Chromate Plated	76
7	05-244	Lock Washer Schnorr M20 Martin #513014	76
8	03-435	Hex Nut M20-2.5 Yellow Chromate Plated	76
9	04-1131	HHCS M8 x 30 mm LG	64
10	S48B00829	10" Inspection Cover	8
11	3916067	Gasket, Full Face ANSI Flange 150 lbs., 10"	3
12	5647011	Valve, Butterfly 12" Wafer Body with Handle & 10 Position Throttle Plate	2
13	5644042	Valve, Butterfly 10" Wafer Body with Handle & 10 Position Throttle Plate	4
14	05-308	Flat Washer M24 Regular	216
15	1493001	Screw Hex Head, Grade 8.8, Yellow Chromate Plated	12
16	05-309	Split Lock Washer M24	108
17	03-412	Hex Nut M24	108
18	1493002	Screw Head Head M24-3.0 x 180 mm, Grade 8.8, Yellow Chromate Plated	72
19	1493003	HHCS M24-3.0 x 90 mm, Yellow Chromate Plated	24
20	9672303	Starter Kit, 3 Motor, UL	4
21	04-1110	HHCS M12 x 40 mm LG	4

**ELECTRICAL
SCHEMATICS**

WIRING SCHEMATIC – 2 MOTOR/UL

220-240V
380-415V
440-480V
550-600V

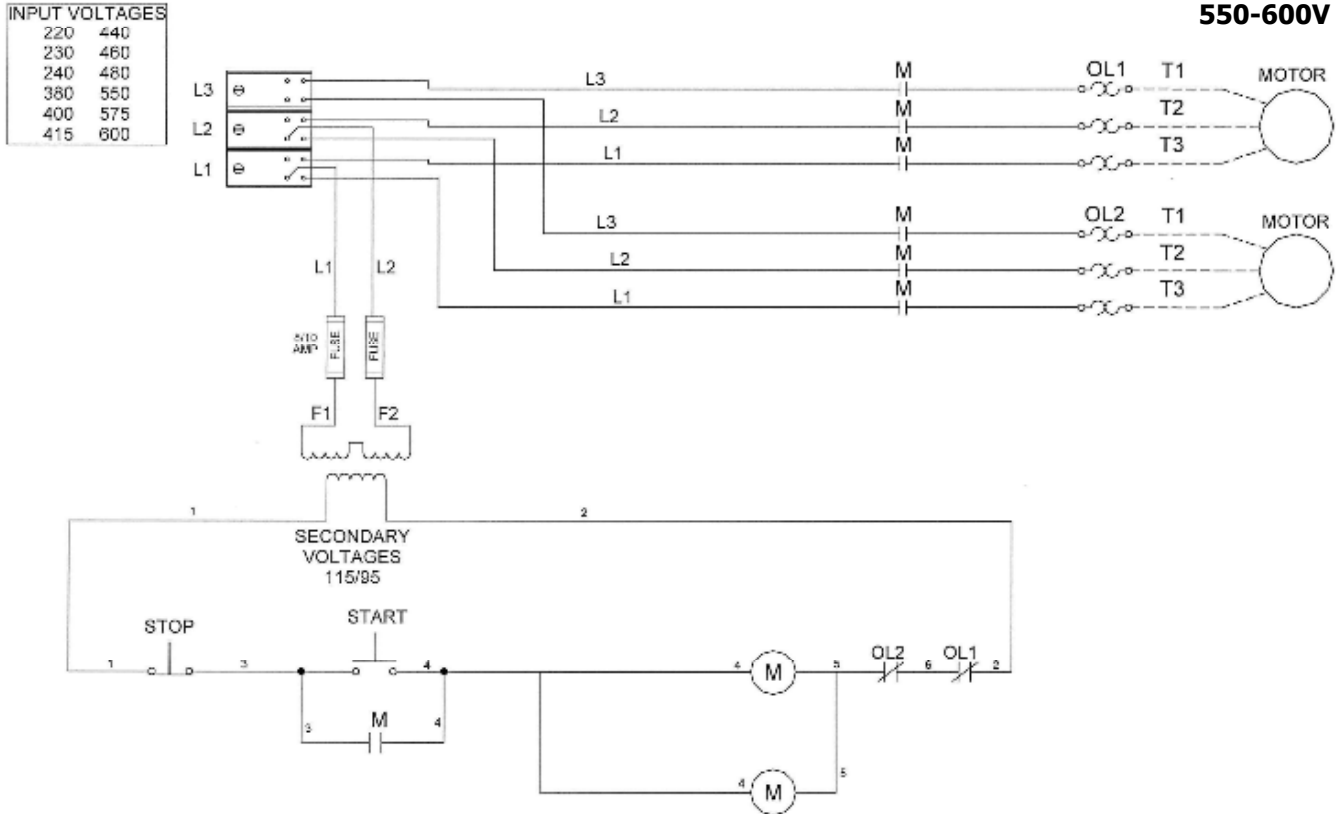

WIRING SCHEMATIC – 3 MOTOR/UL

SWITCH LEGEND

pos. cont.	1-2
LINEAR	
ELLIPTICAL	X

X = Contacts closed

POWER SUPPLY AND MULTIPLE VOLTAGE OPTIONS

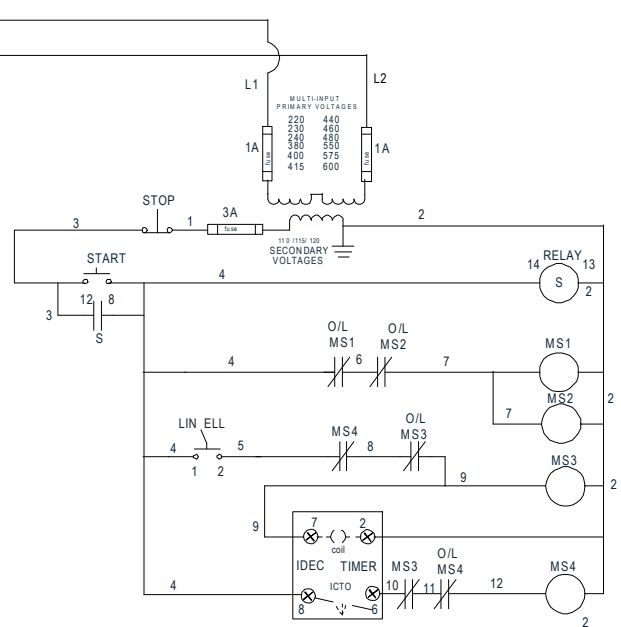
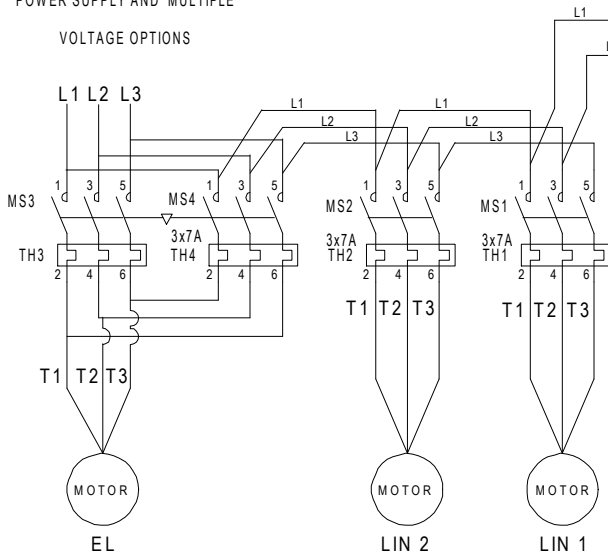

WIRING SCHEMATIC – 2 MOTOR/ATEX

380 - 415V

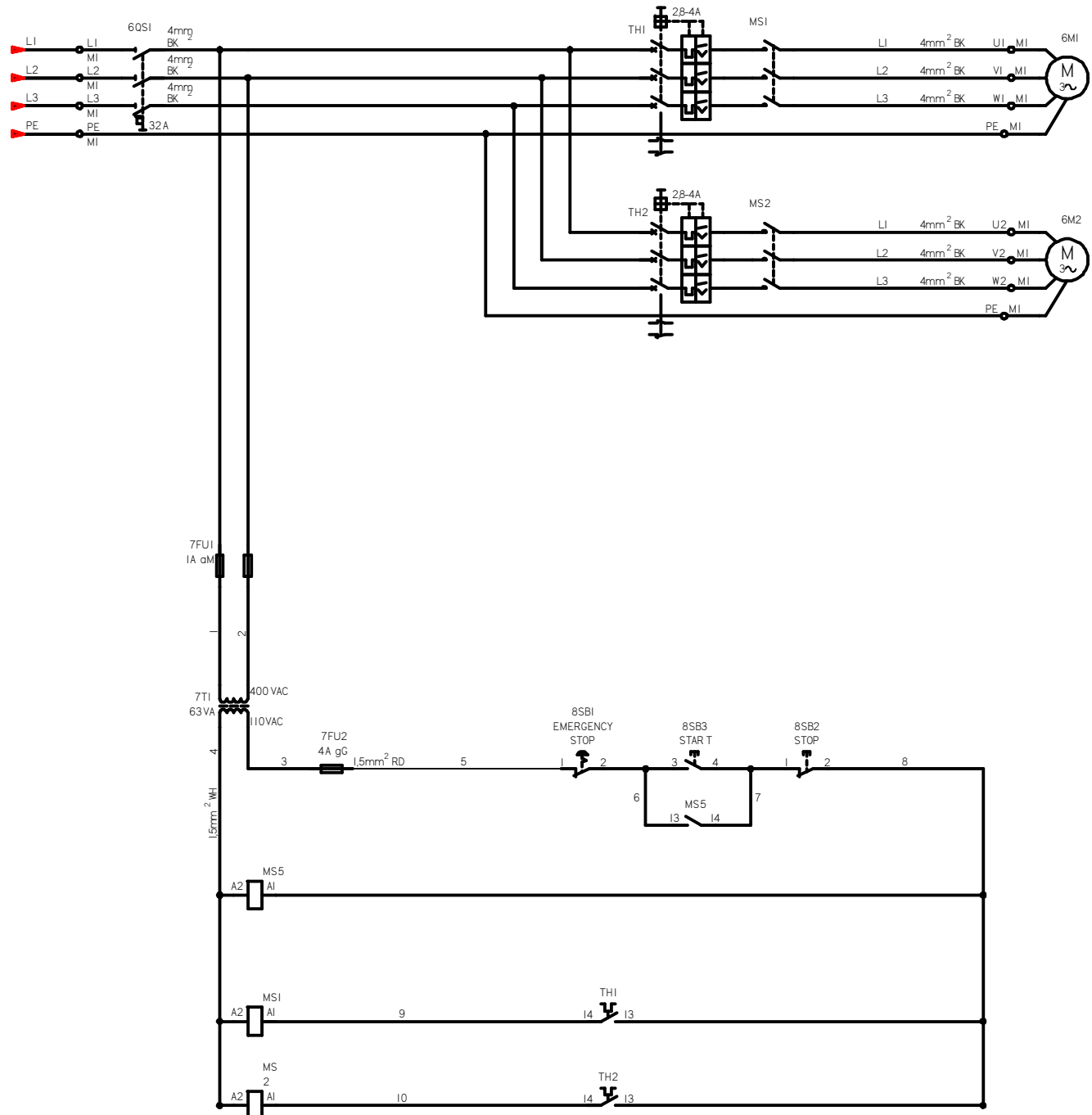

380 – 415V/50 Hz
 440 – 480V/60 Hz

WIRING SCHEMATIC – 3 MOTOR/ATEX

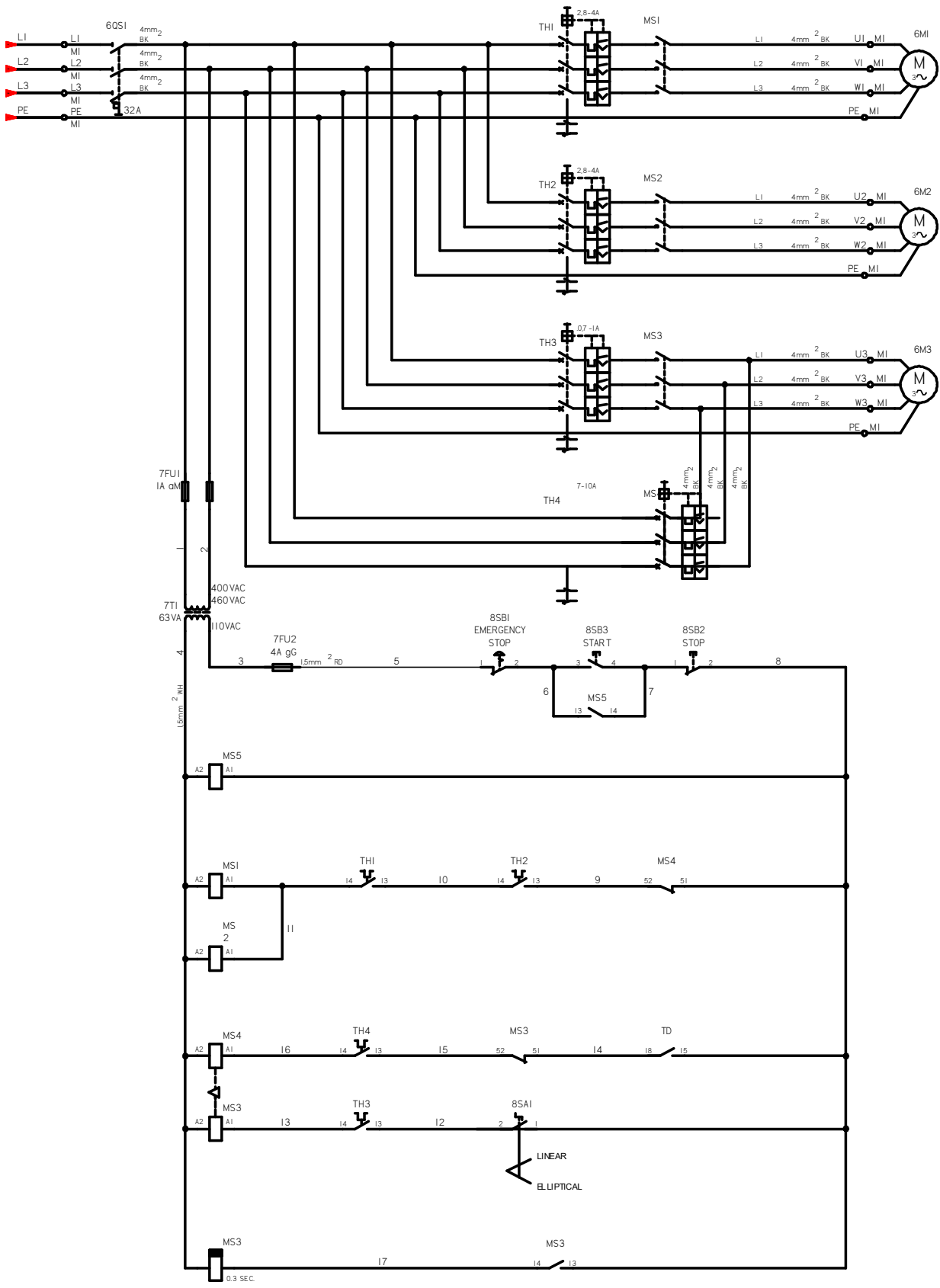



Worldwide Headquarters

P.O. Box 42842

Houston, TX 77242-2842

Tel: 281-561-1300

Fax: 281-561-1441

www.miswaco.com

E-mail: questions@miswaco.com