



# Gate-Style DEMCO Valves

Dependability, inline repairability, flexible trim options, and drop-tight position shutoff

# Contents

Introduction .....	3
Series DM gate valves .....	4
Product specifications .....	5

## **Dimensions, materials, and parts list**

### **Series DM gate valves**

7,500-psi working pressure (WP) .....	6
5,000-psi WP .....	14
ASME Class 600 .....	22
ASME Class 900 .....	24
ASME Class 1500 .....	26

### **Series DMA gate valve**

7,500-psi WP—automated .....	30
5,000-psi WP—automated .....	38



*Oklahoma City, Oklahoma, USA.*

## Introduction

Cameron is a leading provider of valves, valve automation, and measurement systems to the oil and gas industry. Our products are primarily used to control, direct, and measure the flow of oil and gas as it is moved to refineries, petrochemical plants, and industrial centers for processing.

We provide valve products that are sold through distributor networks worldwide. Our products are used in oil and gas and industrial applications and include widely recognized brands such as DEMCO\* valves; NAVCO\* floating ball valves; NEWCO\* gate, globe, and check valves; DOUGLAS CHERO\* forged-steel gate, globe, and check valves; NUTRON\* ball valves; TOM WHEATLEY\* check valves; WHEATLEY\* check valves; and WKM\* valves.

Designed for dependable, heavy-duty performance in abrasive and corrosive service conditions, butterfly-style DEMCO valves are commonly selected for a number of oilfield applications, including drilling and production.

# Series DM Gate Valves

Series DM gate valves, the premier gate valve in the oil and gas drilling market, are specifically engineered for the rigorous requirements of oilfield applications. Designed for dependable, heavy-duty performance in abrasive service conditions, Series DM gate valves are commonly selected for a number of oilfield applications, including

- drilling standpipe manifold
- pump manifold block valves
- high-pressure mud mixing lines
- high-pressure drilling system block valves.

The Series DM gate valves are available in ASME Classes 600, 900, and 1500. They also are available in 5,000-psi gauge pressure and 7,500-psi gauge pressure (not API monogrammed).

## Features and benefits

### Inline field repairability

The bonnet is easily removed for internal parts inspection, replacement, or both without removing the valve from the line. This design simplicity permits fast and easy service without the need for special tools.

### Flexible trim offerings

Optional materials for stems, gates, seat inserts, and seat elastomers make it easier to trim valves for a wide range of service conditions.

### Automation

Automation is available for 5,000- and 7,500-psi pressure-rated valves.

### Exclusive seats design for drop-tight sealing

The Series DM gate valve seats use an unique design to provide a drop-tight shutoff in abrasive and erosive service.

The valves conform to

- American Bureau of Shipping (ABS)
- Det Norske Veritas (DNV)
- NACE MR0175.

### Series DM 7500

The seat consists of two identical metal wear rings encapsulated in elastomer to form a cylindrical shape with a gate slot and two round ports. The closed gate bears on the downstream wear ring, and the elastomer provides a drop-tight pressure-responsive seal around the port.

### Series DM 5000, Class 600, 900, 1500

The cylindrical seat assembly fits into the machined body cavity and is expanded outward toward the valve ports by the bonnet and spread ring in the bottom of the seat. The expansion occurs when the bonnet is tightened onto the body while engaging the seat pin extensions from both wear rings. The spread ring ensures the seat elastomer presses uniformly against the body bore. This design ensures that the seat seals tight against the body and around each valve port. This design has proved to be effective even if the gate and seat ring become scored or abraded during service. When it comes time for maintenance, the seat's single-piece design makes it easy to pull out of the body for replacement.



5-in [130-mm] 7,500-psi WP Series DM gate valve.



5-in [130-mm] 5,000-psi WP Series DMA gate valve.

DM Series Pressure Classes and Sizes						
Port	Size, in [mm]	Pressure Classes				
		600	900	1500	5000	7500
Full port (FP)	2 [50]	●	●	●	●	
	2½ [65]	●	●	●		
	3 [80]	●	●	●	●	●
	4 [100]	●	●	●	●	●
	5 [125]				●	●
	6 [150]	●	●			
Reduced port (RP)	2 × 1½ [50 × 40]	●				
	2½ × 2 [65 × 50]				●	
	3 × 2 [80 × 50]	●				
	4 × 3 [100 × 80]				●	●
	5 × 4 [125 × 100]				●	●
	6 × 4 [150 × 100]				●	
	6 × 5 [150 × 125]				●	●
	8 × 6 [200 × 150]	●				

# Product Specifications

## Series DM gate valve general technical information

### Valve size designations and weld end dimensional information

All references to pipe size in this catalog are the nominal size. The actual OD and ID for various nominal sizes and schedules are tabulated below. Weld end bodies are machined at each end to match the pipe OD and ID.

Nominal Size, in [mm]	OD	ID			
		Sch. 40	Sch. 80	Sch. 160	XXH
1½ [40]	1.900	1.610	1.500	—	—
2 [50]	2.375	2.067	1.939	1.687	1.503
2½ [65]	2.875	2.469	2.323	2.125	1.771
3 [80]	3.500	3.068	2.900	2.624	2.300
4 [100]	4.500	4.026	3.826	3.438	3.152
5 [125]	5.563	—	4.813	4.313	4.063
6 [150]	6.625	6.065	5.761	5.187	4.897

### Quality, inspections, and testing

- The Cameron quality system is based on ISO 9000 and API Spec Q1 requirements and is ISO 9001:2008 certified. Cameron monitors all phases of valve production, from material receipt to final inspection, including liaising with third-party inspectors and certifying authorities. All gate-style DEMCO valves are hydrostatically tested; stem seal, body, and seat are inspected for zero leakage under pressure before being released for shipment. Hydrotest specifications are based upon the latest-edition API Spec 6A testing requirements; Series DM 7500 Groups 2 and 3 valves undergo additional test cycles, including low-pressure seat tests prior to being released for shipment.
- **Group 1**—Basic valve. Hydrostatic shell test—11,250 psi for 3 min. Hydrostatic seat test—7,500 psi for 3 min, each side. Material traceability on body and bonnet.

- **Group 2**—Same as Group 1, except hydrostatic shell test—11,250 psi for 3 min, drop to 0 psi, then 11,250 psi for 15 min. Test is charted. Hydrostatic seat test—7,500 psi for 3 min, drop to 0 psi, 7,500 psi for 15 min, drop to 0 psi, then 300 psi for 5 min, each side. Test is charted. Material traceability on body, bonnet, stem, and bolting. Impact tests at or below –50 degF [–46 degC] on body, bonnet, stem, and bolting. Surface nondestructive examination (NDE) on body, bonnet, and stem.
- **Group 3**—Same as Group 2, plus volumetric NDE on body and bonnet.

### Seat seal options

- **Buna-N (nitrile)** is excellent for petroleum oil and gases, fuel oils, and alcohols from –10 to 200 degF [–23 to 93 degC].
- **FKM** is highly resistant to mineral acids and hydrocarbons, and is serviceable from –10 to 400 degF [–23 to 204 degC]; not suitable for steam.
- **HNBR** is formulated for use with synthetic and oil-based drilling mud service from –20 to 250 degF [–29 to 121 degC].

### Ordering information

- Give pipe size, pressure class, and end connection.
- Specify pressure class of flanged ends, raised face (RF), or ring type joint (RTJ).
- For threaded ends, provide type of pipe:
  - nonupset tubing (TBG)
  - long casing thread (LCSG)
  - external upset tubing (UPTBG)
  - short casing thread (CSG).
- For weld ends, give schedule of mating pipe.

# Dimensions, Materials, and Parts List

Series DM gate valves—7,500-psi WP

2-in [50-mm] seat port

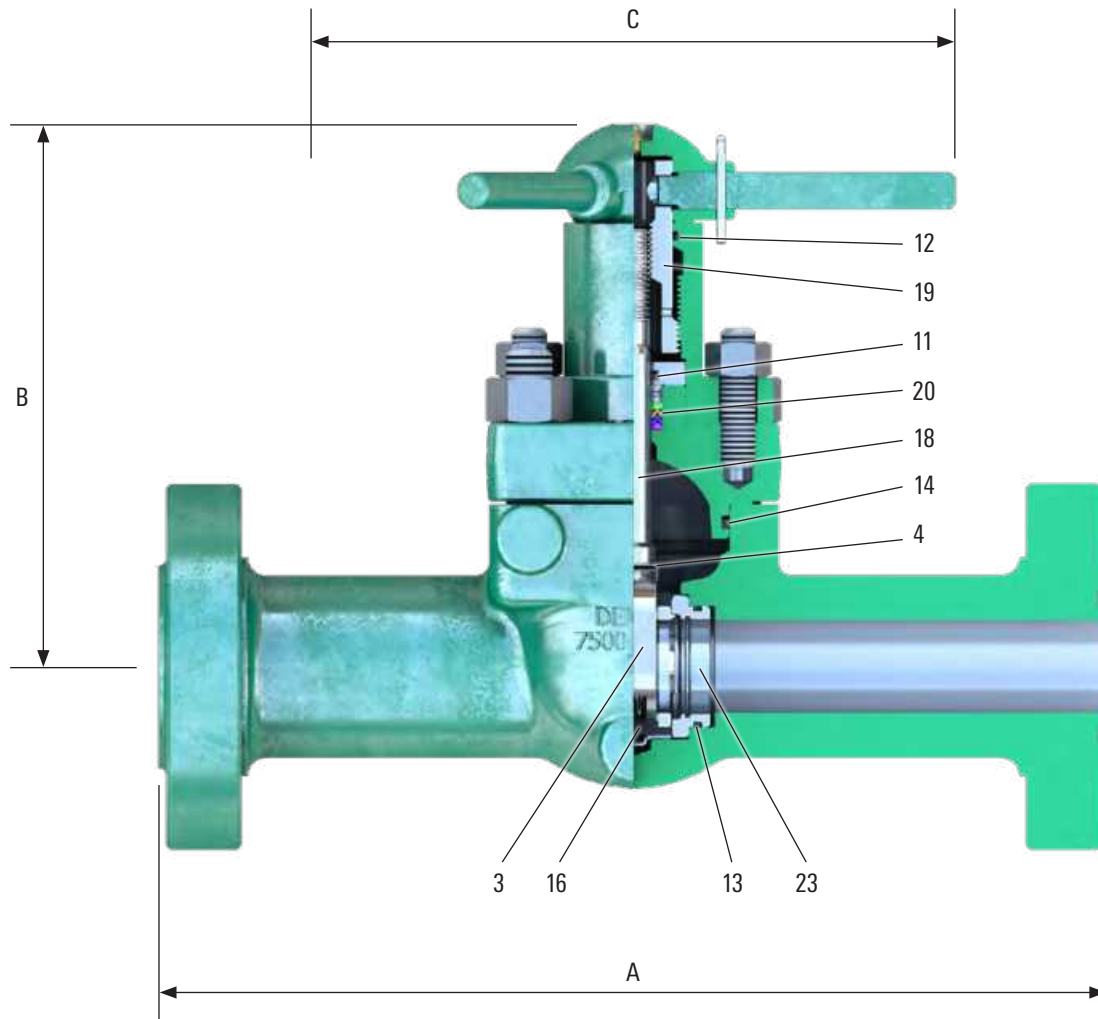

## Dimensional Data and Weights

Dimension	Valve Seat Port Size for 7,500-psi WP: 2 in [50 mm]	
A, length, in [mm]	Weld end	9.00 [229]
	Flanged end, API length	20.50 [521]
	Hammer union end	15.74 [400]
For flanged ends	API ring number	BX-152
	Flange ID, in [mm]	2.00 [50]
	Flange OD, in [mm]	7.88 [200]
	Flange bolts, amount; in [mm]	8; ¾ [19]
Weight, lbm [kg]	Weld end	83 [38]
	Flanged end	144 [65]
	Hammer union end	101 [46]
Number of handle turns from open to closed	8.6	
B, height, center to top (open), in [mm]	13.04 [331]	
C, handle diameter, in [mm]	14.00 [356]	



Assembly Part Number Example

**J025088-3 7 7 2 1 4 0**

Assembly Base Number  
2 in [50 mm], Group 1

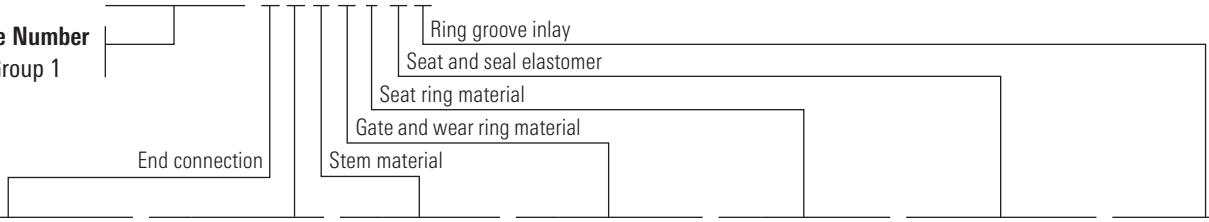

End Connection		Body Configuration		Stem Material		Gate and Wear Ring Material		Seat Ring Material		Seat and Seal Elastomer		Ring Groove Inlay	
No.	Description	No.	Description	No.	Description	No.	Description	No.	Description	No.	Description	No.	Description
<b>Flanged</b>		5	Weld	7	410 stainless steel (SS)	2	41XX and 41XX	1	410 SS	2	FKM and FKM	0	—
3	10,000 RTJ	7	Flanged			7	410 SS and 410 SS			4	HNBR and HNBR	1	316 SS inlay <sup>†</sup>
<b>Weld</b>		9	Hammer union									2	625 SS inlay <sup>†</sup>
2	2.00-in [50 mm] XXH												
4	3.00-in [80-mm] OD × 2.00-in [50-mm] ID												
<b>Hammer union</b>													
9	2.00-in [50-mm] XXH 1502 hammer union												

<sup>†</sup> Inlay only available on flanged valves.

Parts List

Repair Kit	Key No.	Qty.	Description	Valve Seat Port Size for 7,500-psi WP: 2 in [50 mm]			Repair Kit Component Part Numbers
				Group 1	Group 2	Group 3	
			<b>Assembly Base Number—NACE Compliant</b>	<b>J025088</b>	<b>J025103</b>	<b>J025104</b>	
	1	1	Body	ASTM A487 Gr. 4 Class D			—
	2	1	Bonnet	4130			—
■ ●	3	1	Gate	41XX with quench, polish, quench (QPQ) nitriding			2171111-01
				410 SS with QPQ nitriding			2139624-02
■ ●	4	1	Gate clip	3XX SS			M450480
	5	1	Handle	ASTM A536 Gr. 65-45-12			—
	6	4	Heavy hex nut, 1-8 UNC	ASTM A194 Gr. 2H	ASTM A194 Gr. 7		—
	7	2	Heavy hex nut, ¾-10 UNC	ASTM A194 Gr. 2H	ASTM A194 Gr. 7		—
	8	1	Housing	ASTM A350 Gr. LF2 Class 1			J024982
	9	1	Lock handle	CD 1213/15			—
	10	1	Lubricating nipple, ½ NPT	Steel			—
■	11	1	O-ring, AS-568-210, secondary seal	HNBR			2712425-13
				FKM			J005531-210
■	12	1	O-ring, AS-568-224, housing seal	Buna-N			J005526-224
■ ●	13	2	O-ring, AS-568-229, wear ring seal	HNBR			2712425-03
				FKM			J005521-229
■ ●	14	1	O-ring, AS-568-342, bonnet seal	HNBR			2712425-60
				FKM			J005521-342
	15	1	Retainer	CD 1213/15	17-4PH SS		—
■ ●	16	1	Seat assembly	410 SS with QPQ nitriding and HNBR			2139742-01
				410 SS with QPQ nitriding and FKM			2139741-02
	17	1	Split pin, ⅜ in × 1¼ in [5 × 45]	Steel			—
■	18	1	Stem	410 SS			J024983-107
■	19	1	Stem screw	CD 1213/15			J001913
■	20	1	Stem seal assembly with bushing	HNBR and bronze			JN23231-008
				FKM and bronze			JN23231-006
	21	4	Stud (double ended), 1-8 UNC × 4.50 (long)	ASTM A193 Gr. B7	ASTM A193 Gr. L7		—
	22	2	Stud (double ended), ¾-10 UNC × 3.00 (long)	ASTM A193 Gr. B7	ASTM A193 Gr. L7		—
■ ●	23	2	Wear ring	41XX with QPQ nitriding			M452267
				410 SS			2139647-02

■ Major repair kit J025177-10274—one each for one year of service.  
 ● Minor repair kit J025177-00274.  
 Major and minor repair kits listed for trim option J0XXXX-XX72140 (410 SS stem, 41XX with QPQ gate, HNBR seat and seals).  
 Consult Cameron for other repair kit trim options.

# Series DM gate valves — 7,500-psi WP

3-in [80-mm] seat port

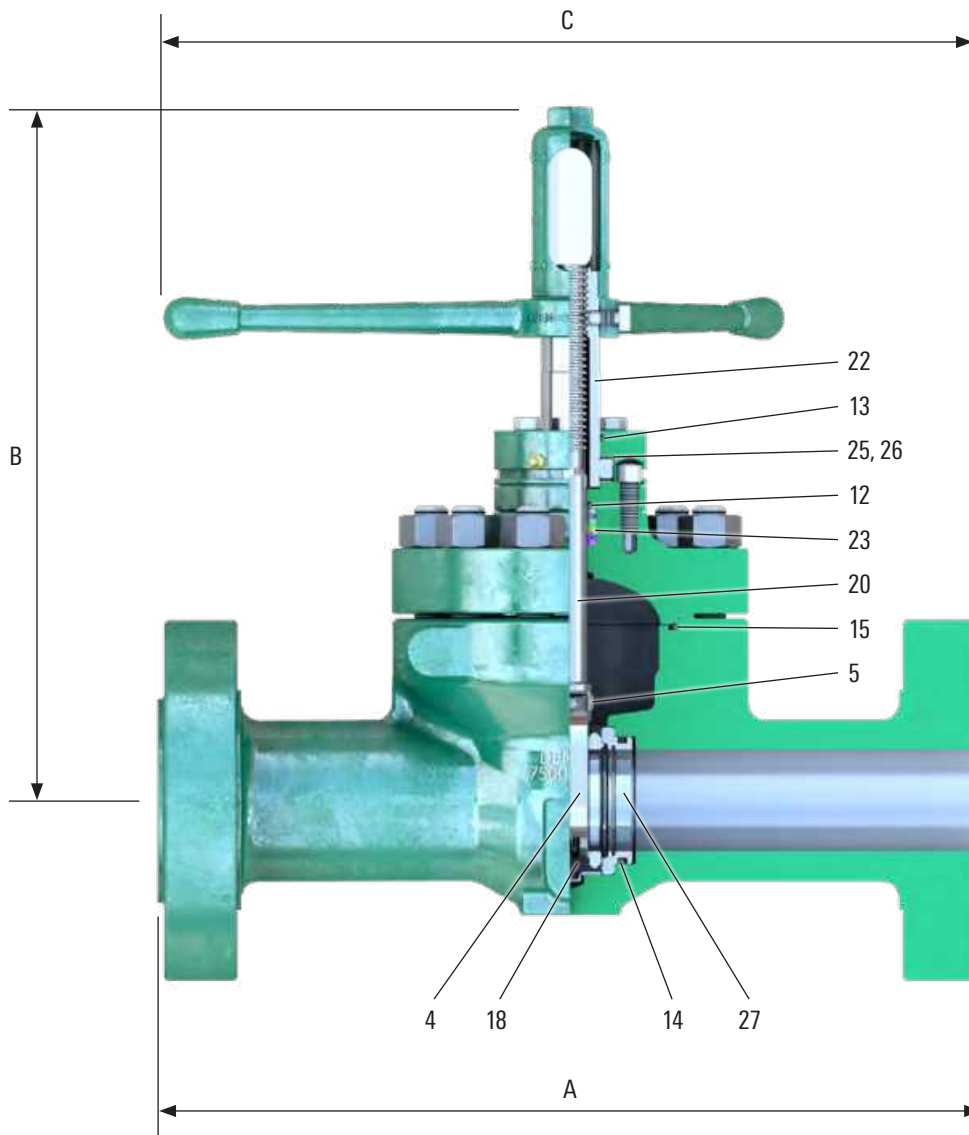

## Dimensional Data and Weights

Dimension	Valve Seat Port Size for 7,500-psi WP: 3 in [80 mm]		
A, length, in [mm]	Weld end	13.00 [330]	
	Flanged end	24.38 [619]	
	Hammer union end	4 in	24.62 [625]
		3 in	18.88 [480]
For flanged ends	API ring number	BX-154	
	Flange ID, in [mm]	3.00 [80]	
	Flange OD, in [mm]	10.62 [270]	
	Flange bolts, amount; in [mm]	8; 1 [25]	
Weight, lbm [kg]	Weld end	185 [84]	
	Flanged end	299 [136]	
	Hammer union end	4 in	269 [122]
		3 in	211 [96]
Number of handle turns from open to closed	16.0		
B, height, center to top (open), in [mm]	20.48 [520]		
C, handle diameter, in [mm]	24.00 [610]		



Assembly Part Number Example

**J025299-3 7 7 2 1 2 1**

Assembly Base Number  
3 in [80 mm], Group 1

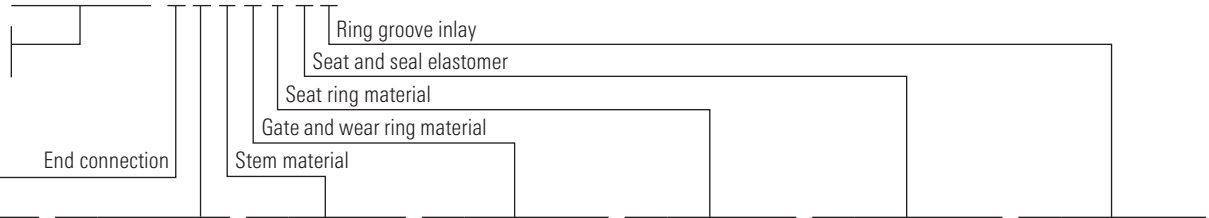

End Connection		Body Configuration		Stem Material		Gate and Wear Ring Material		Seat Ring Material		Seat and Seal Elastomer		Ring Groove Inlay	
No.	Description	No.	Description	No.	Description	No.	Description	No.	Description	No.	Description	No.	Description
<b>Flanged</b>		5	Weld	7	410 SS	2	41XX and 41XX	1	410 SS	2	FKM and FKM	0	–
3	10,000 RTJ	7	Flanged			7	410 SS and 410 SS			4	HNBR and HNBR	1	316 SS inlay <sup>†</sup>
<b>Weld</b>		9	Hammer union									2	625 SS inlay <sup>†</sup>
2	3.00-in [80-mm] XXH												
4	4.00-in [100-mm] XXH												
5	4.50-in [114-mm] OD × 2.96-in [75-mm] ID												
<b>Hammer union</b>													
8	3.00-in [80-mm] XXH 1502 hammer union												
9	4.00-in [100-mm] XXH 1502 hammer union												

<sup>†</sup> Inlay only available on flanged valves.

Parts List

Repair Kit	Key No.	Qty.	Description	Valve Seat Port Size for 7,500-psi WP: 3 in [80 mm]			Repair Kit Component Part Numbers
				Group 1	Group 2	Group 3	
Assembly Base Number — NACE Compliant				J025299	J025300	J025301	
	1	1	Body	ASTM A487 Gr. 4 Class D			–
	2	1	Bonnet	4130			–
	3	4	Capscrew socket head, ½ UNC × 1.50 (long)	ASTM A574 Alloy Steel	18-8 SS		–
■ ●	4	1	Gate	41XX with QPQ nitriding			2171112-01
				410 SS with QPQ nitriding			2139628-02
■ ●	5	1	Gate clip	3XX SS			M450505
	6	1	Handle	ASTM A536 Gr. 65-45-12			–
	7	1	Handle screw	CD 1018/26			–
	8	12	Heavy hex nut, 1-8 UNC	ASTM A194 Gr. 2H	ASTM A194 Gr. 7		–
	9	1	Housing	HR 1018/22			–
	10	4	Hex head bolt, ½-13 UNC × 3.00 (long)	SAE International steel Gr. 5			–
	11	1	Lubricating nipple, ½ NPT	Steel			–
■	12	1	O-ring, AS-568-214, secondary seal	HNBR			2712425-01
				FKM			J005531-214
■	13	1	O-ring, AS-568-224, housing seal	Buna-N			J005526-224
■ ●	14	2	O-ring, AS-568-340, wear ring seal	HNBR			2712783-03
				FKM			J005521-340
■ ●	15	1	O-ring, AS-568-361, bonnet seal	HNBR			2712787-07
				FKM			J005521-361
	16	1	Relief fitting, ½ NPT	Steel			–
	17	1	Retainer	HR 1018/22	17-4PH SS		–
■ ●	18	1	Seat assembly	410 SS with QPQ nitriding and HNBR			2139744-01
				410 SS with QPQ nitriding and FKM			2139743-02
	19	1	Sight tube	Clear acrylic			–
■	20	1	Stem	410 SS			213597-01
	21	1	Stem cap	ASTM A536 Gr. 65-45-12			–
■	22	1	Stem screw	CD 1018/26			213600-01
■	23	1	Stem seal assembly with bushing	HNBR and bronze			JN01951-008
				FKM and bronze			JN01951-006
	24	12	Stud (double ended), 1-8 UNC × 4.50 (long)	ASTM A193 Gr. B7	ASTM A193 Gr. L7		–
■	25	2	Thrust needle roller bearing	Hardened steel			50315432
■	26	4	Thrust washer	Hardened steel			50315409
■ ●	27	2	Wear ring	41XX with QPQ nitriding			M452571
				410 SS			2139648-02

■ Major repair kit J025177-11374—one each for one year of service.

● Minor repair kit J025177-00374.

Major and minor repair kits listed for trim option J0XXXX-XX72140 (410 SS stem, 41XX with QPQ gate, and HNBR seat and seals).

Consult Cameron for other repair kit trim options.

# Series DM gate valves — 7,500-psi WP

4-in [100-mm] seat port

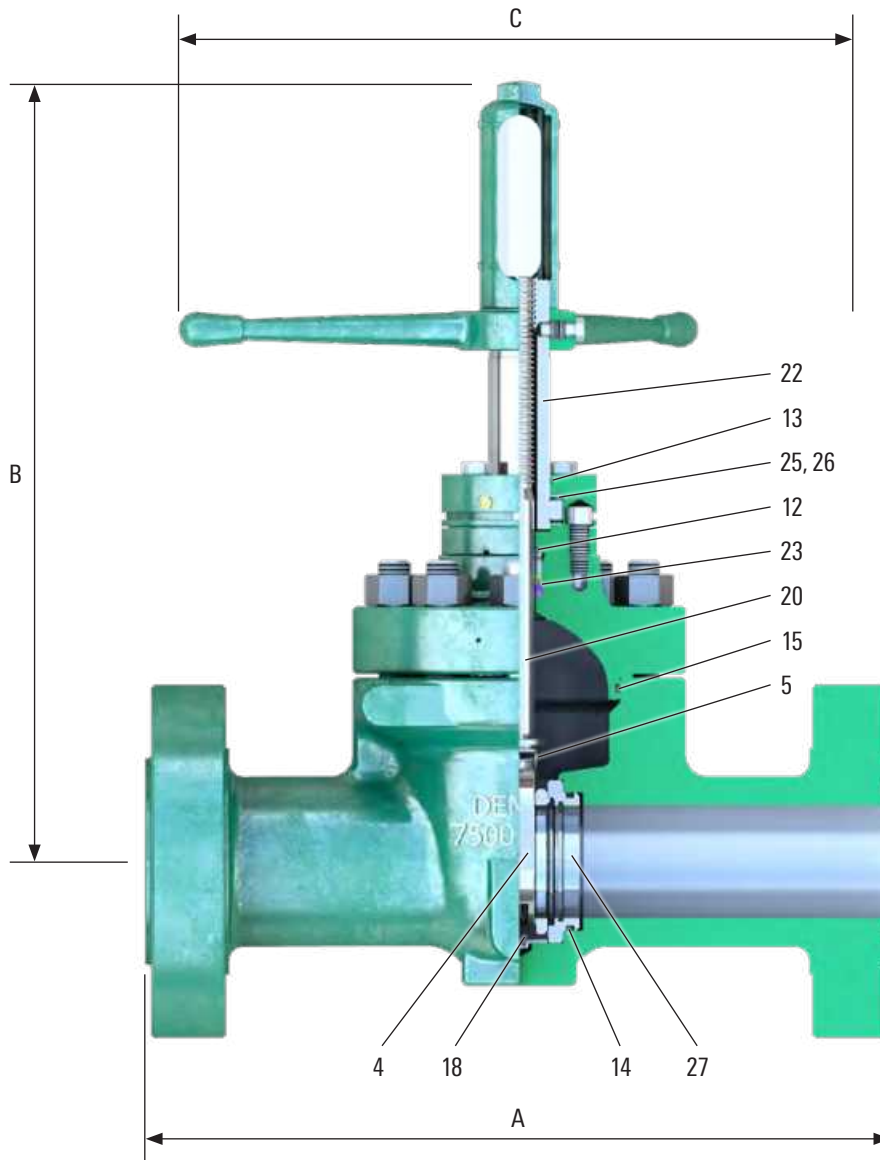

## Dimensional Data and Weights

Dimension	Valve Seat Port Size for 7,500-psi WP: 4 in [100 mm]		
A, length, in [mm]	Weld end	16.00 [406]	
	Flanged end	26.38 [670]	
	Hammer union end	5 in	25.62 [651]
		4 in	27.62 [702]
For flanged ends	API ring number	BX-155	
	Flange ID, in [mm]	4.00 [100]	
	Flange OD, in [mm]	12.44 [316]	
	Flange bolts, amount; in [mm]	8; 1½ [29]	
Weight, lbm [kg]	Weld end	281 [127]	
	Flanged end	456 [207]	
	Hammer union end	5 in	379 [172]
		4 in	365 [166]
Number of handle turns from open to closed	21.3		
B, height, center to top (open), in [mm]	27.53 [699]		
C, handle diameter, in [mm]	24.00 [610]		



Assembly Part Number Example

**J025102-3772142**

**Assembly Base Number**  
4 in [100 mm], Group 1

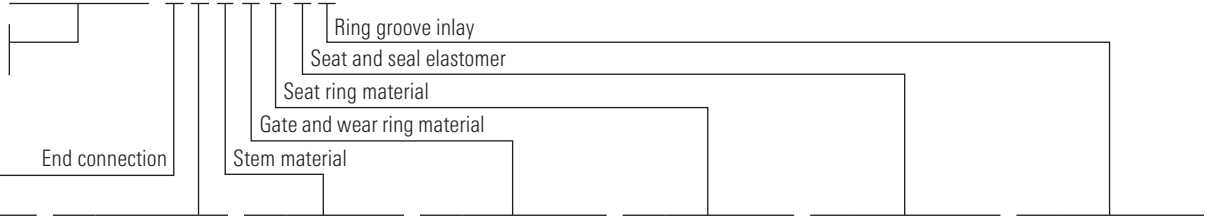

End Connection	Body Configuration	Stem Material	Gate and Wear Ring Material	Seat Ring Material	Seat and Seal Elastomer	Ring Groove Inlay
No. Description	No. Description	No. Description	No. Description	No. Description	No. Description	No. Description
<b>Flanged</b>	5 Weld	7 410 SS	<b>2 41XX and 41XX</b>	1 410 SS	<b>2 FKM and FKM</b>	0 –
<b>Weld</b>	7 Flanged		<b>7 410 SS and 410 SS</b>		<b>4 HNBR and HNBR</b>	1 316 SS inlay <sup>†</sup>
3 10,000 RTJ	9 Hammer union					2 625 SS inlay <sup>†</sup>
2 4.00-in [100-mm] XXH						
3 5.00-in [125-mm] XXH						
4 5.81-in [148-mm] OD × 4.06-in [103-mm] ID						
5 6.00-in [152-mm] OD × 4.00-in [100-mm] ID						
<b>Hammer union</b>						
8 4.00-in [100-mm] XXH 1502 hammer union						
9 5.00-in [125-mm] XXH 1502 hammer union						

<sup>†</sup> Inlay only available on flanged valves.

**Parts List**

Repair Kit	Key No.	Qty.	Description	Valve Seat Port Size for 7,500-psi WP: 4 in [100 mm]			Repair Kit Component Part Numbers
				Group 1	Group 2	Group 3	
				J025102	J025107	J025108	
			<b>Assembly Base Number—NACE Compliant</b>				
	1	1	Body	ASTM A487 Gr. 4 Class D			–
	2	1	Bonnet	4130			–
	3	4	Capscrew socket head, 5/8 UNC × 1.75 (long)	ASTM A574 Alloy Steel	18-8 SS		–
■ ●	4	1	Gate		41XX with QPQ nitriding	2171267-01	
					410 SS with QPQ nitriding	2139637-02	
■ ●	5	1	Gate clip		3XX SS	M450505	
	6	1	Handle	ASTM A536 Gr. 65-45-12			–
	7	1	Handle screw	CD 1018/26			–
	8	10	Heavy hex nut, 1 1/8 UNC	ASTM A194 Gr. 2H	ASTM A194 Gr. 7		–
	9	4	Hex head bolt, 5/8-11 UNC × 3.50 (long)	SAE steel Gr. 5			–
	10	4	Housing	HR 1018/22			–
	11	1	Lubricating nipple, 1/8 NPT	Steel			–
■	12	1	O-ring, AS-568-216, secondary seal		HNBR	2726268-01	
					FKM	J005531-216	
■	13	1	O-ring, AS-568-228, housing seal		Buna-N	J005526-228	
■ ●	14	2	O-ring, AS-568-349, wear ring seal		HNBR	2712787-04	
					FKM	J005521-349	
■ ●	15	1	O-ring, AS-568-364, bonnet seal		HNBR	2712426-11	
					FKM	J005521-364	
	16	1	Relief fitting, 1/8 NPT	Steel			–
	17	1	Retainer	HR 1018/22	17-4PH SS		–
■ ●	18	1	Seat assembly		410 SS with QPQ nitriding and HNBR	2139746-01	
					410 SS with QPQ nitriding and FKM	2139745-02	
	19	1	Sight tube	Clear acrylic			–
■	20	1	Stem	410 SS			2140684-01
	21	1	Stem cap	ASTM A536 Gr. 65-45-12			–
■	22	1	Stem screw	CD 1018/26			J019159
■	23	1	Stem seal assembly with bushing		HNBR and bronze	JN15853-008	
					FKM and bronze	JN15853-006	
	24	10	Stud (double ended), 1 1/8 UNC × 5.50 (long)	ASTM A193 Gr. B7	ASTM A193 Gr. L7		–
■	25	2	Thrust needle roller bearing	Hardened steel			J050911-005
■	26	4	Thrust washer	Hardened steel			J050911-006
■ ●	27	2	Wear ring		41XX with QPQ nitriding	M452290	
					410 SS	2139649-02	

■ Major repair kit J025177-10474—one each for one year of service.

● Minor repair kit J025177-00474.

Major and minor repair kits listed for trim option J0XXXXX-XX72140 (410 SS stem, 41XX with QPQ gate, and HNBR seat and seals).

Consult Cameron for other repair kit trim options.

# Series DM gate valves — 7,500-psi WP

## 5.12-in [130-mm] seat port

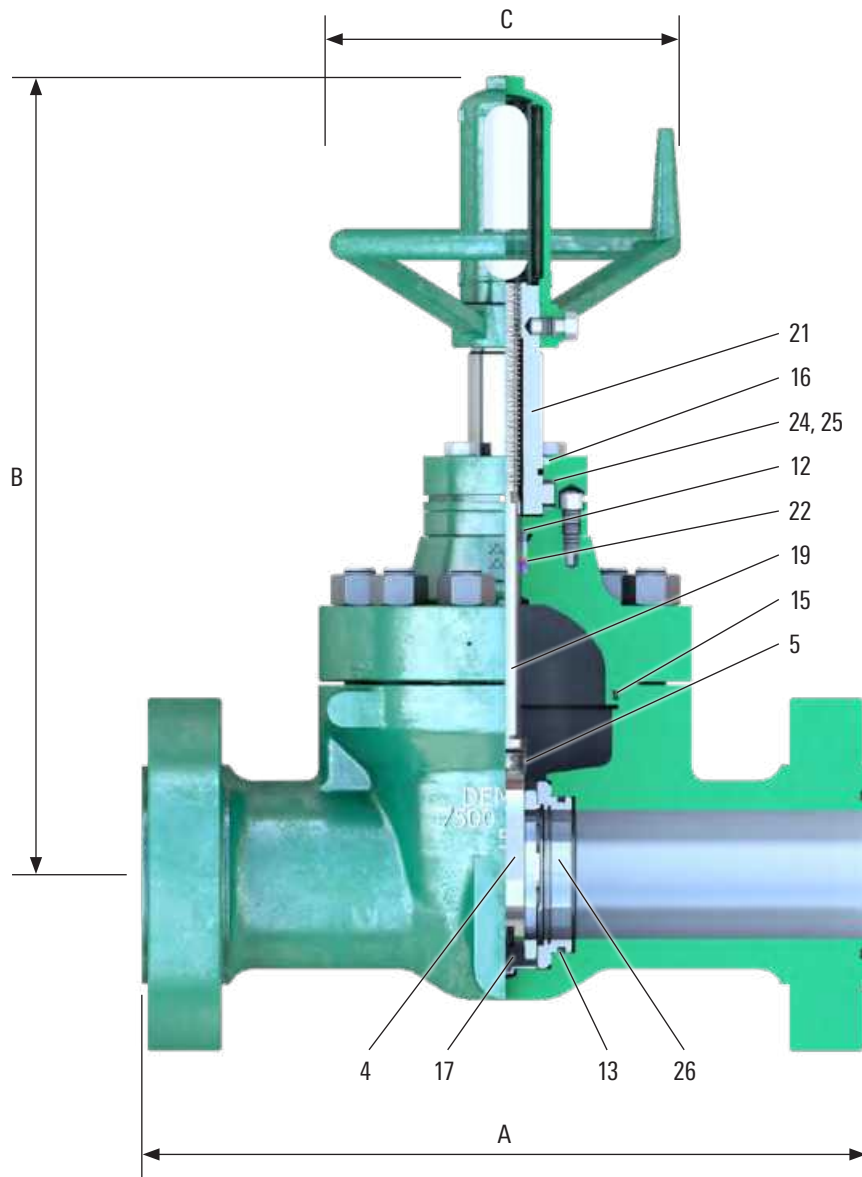

### Dimensional Data and Weights

Dimension	Valve Seat Port Size for 7,500-psi WP: 5.12 in [130 mm]	
A, length, in [mm]	Weld end	17.88 [454]
	Flanged end	29.00 [737]
For flanged ends	API ring number	BX-169
	Flange ID, in [mm]	5.12 [130]
	Flange OD, in [mm]	14.06 [357]
	Flange bolts, amount; in [mm]	12; 1 1/8 [29]
Weight, lbm [kg]	Weld end	532 [241]
	Flanged end	772 [350]
Number of handle turns from open to closed		27.8
B, height, center to top (open), in [mm]		31.87 [809]
C, handle diameter, in [mm]		24.00 [610]



Assembly Part Number Example

**J025090-3 7 7 7 1 2 0**

**Assembly Base Number**  
5.12 in [130 mm],  
Group 1

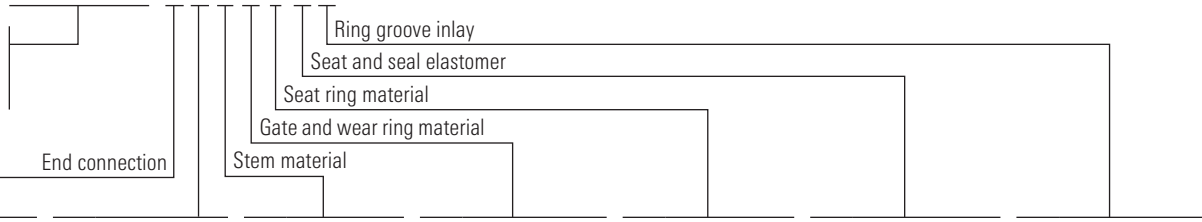

End Connection		Body Configuration		Stem Material		Gate and Wear Ring Material		Seat Ring Material		Seat and Seal Elastomer		Ring Groove Inlay	
No.	Description	No.	Description	No.	Description	No.	Description	No.	Description	No.	Description	No.	Description
<b>Flanged</b>													
3	10,000 RTJ	5	Weld	7	410 SS	2	41XX and 41XX	1	410 SS	2	FKM and FKM	0	—
<b>Weld</b>													
4	6.00-in [150-mm] XXH	7	Flanged			7	410 SS and 410 SS			4	HNBR and HNBR	1	316 SS inlay <sup>†</sup>
6	7.25-in [184-mm] OD × 5.12-in [130-mm] ID											2	625 SS inlay <sup>†</sup>

<sup>†</sup> Inlay only available on flanged valves.

**Parts List**

Repair Kit	Key No.	Qty.	Description	Valve Seat Port Size for 7,500-psi WP: 5.12 in [130 mm]			Repair Kit Component Part Numbers
				Group 1	Group 2	Group 3	
				J025090	J025109	J025110	
<b>Assembly Base Number — NACE Compliant</b>							
	1	1	Body	ASTM A487 Gr. 4 Class D			—
	2	1	Bonnet	4130			—
	3	4	Capscrew socket head, 5/8 UNC × 1.75 (long)	ASTM A574 Alloy Steel	18-8 SS		—
■ ●	4	1	Gate	41XX with QPQ nitriding			2171108-01
				410 SS with QPQ nitriding			2139629-02
■ ●	5	1	Gate clip	3XX SS			M451649
	6	1	Handle	ASTM A536 Gr. 65-45-12			—
	7	1	Handle screw	CD 1018/26			—
	8	12	Heavy hex nut, 1 1/4-8 UN	ASTM A194 Gr. 2H	ASTM A194 Gr. 7		—
	9	4	Hex head bolt, 3/4-10 UNC × 4.00 (long)	SAE steel Gr. 5			—
	10	1	Housing	HR 1018/22			—
	11	1	Lubricating nipple, 1/2 NPT	Steel			—
■	12	1	O-ring, AS-568-218, secondary seal	HNBR			2712425-12
				FKM			J005531-218
■	13	2	O-ring, AS-568-435, wear ring seal	HNBR			2726268-02
				FKM			J005521-435
■ ●	14	1	O-ring, AS-568-446, bonnet seal	HNBR			2712425-78
				FKM			J005521-446
	15	1	Retainer	HR 1018/22	17-4PH SS		—
■	16	1	Rod wiper, housing seal	Urethane			2726191-02-95
■ ●	17	1	Seat assembly	410 SS with QPQ nitriding and HNBR			2139748-01
				410 SS with QPQ nitriding and FKM			2269500-01
	18	1	Sight tube	Clear acrylic			—
■	19	1	Stem	410 SS			J024943-107
	20	1	Stem cap	ASTM A536 Gr. 65-45-12			—
■	21	1	Stem screw	CD 1018/26			J023415
■	22	1	Stem seal assembly with bushing	HNBR and bronze			JN16995-008
				FKM and bronze			JN16995-006
	23	12	Stud (double ended), 1 1/4-8 UN × 6.25 (long)	ASTM A193 Gr. B7	ASTM A193 Gr. L7		—
■	24	2	Thrust needle roller bearing	Hardened steel			J050911-009
■	25	4	Thrust washer	Hardened steel			J050911-010
■ ●	26	2	Wear ring	41XX with QPQ nitriding			M452619
				410 SS			2139650-02

■ Major repair kit J025177-10574—one each for one year of service.  
● Minor repair kit J025177-00574.

Major and minor repair kits listed for trim option J0XXXX-XX72140 (410 SS stem, 41XX with QPQ gate, and HNBR seat and seals). Consult Cameron for other repair kit trim options.

# Series DM gate valves — 5,000-psi WP

2-in [50-mm] seat port

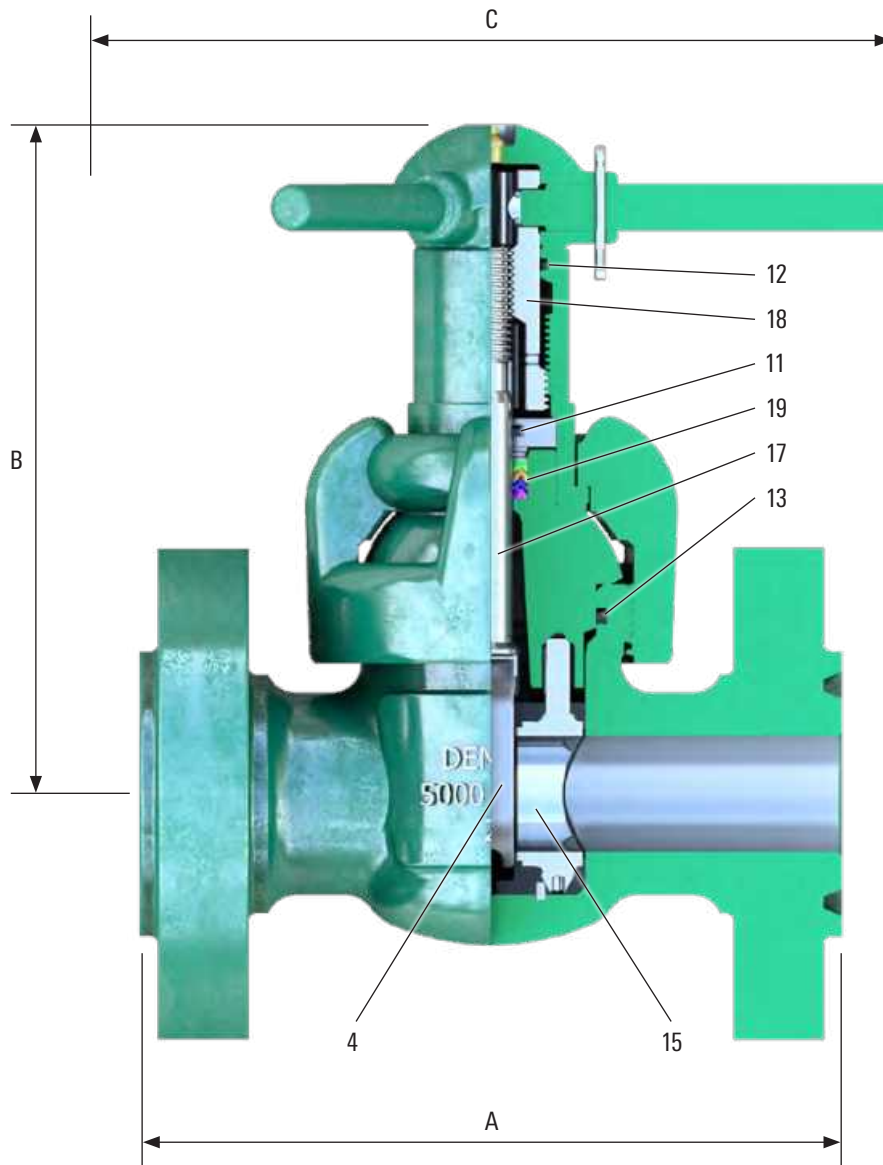

## Dimensional Data and Weights

Dimension	Valve Seat Port Size for 5,000-psi WP: 2 in [50 mm]	
A, length, in [mm]	Weld and threaded end	9.00 [229]
	Flanged end	12.12 [308]
	Hammer union end	15.74 [400]
For flanged ends	API ring number	R-24
	Flange ID, in [mm]	2.00 [50]
	Flange OD, in [mm]	8.50 [216]
	Flange bolts, amount; in [mm]	8; 7/8 [22]
Weight, lbm [kg]	Weld and threaded end	58 [26]
	Flanged end	103 [47]
	Hammer union end	77 [35]
Number of handle turns from open to closed	10.2	
B, height, center to top (open), in [mm]	13.00 [330]	
C, handle diameter, in [mm]	14.00 [356]	



Assembly Part Number Example

**J024929-2782110**

Assembly Base Number

2 in [50 mm]

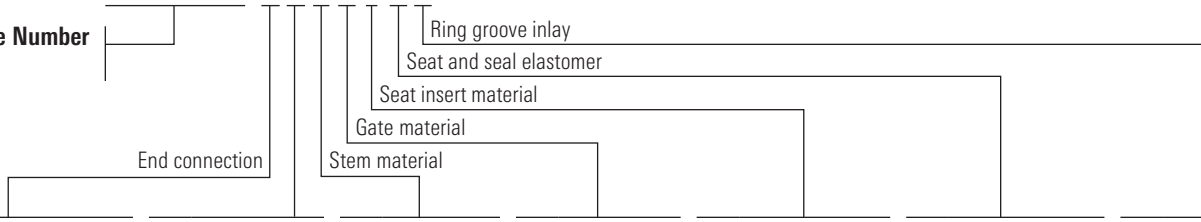

End Connection		Body Configuration		Stem Material		Gate Material		Seat Insert Material		Seat and Seal Elastomer		Ring Groove Inlay	
No.	Description	No.	Description	No.	Description	No.	Description	No.	Description	No.	Description	No.	Description
<b>Flanged</b>		4	Threaded	8	316 SS	2	41XX	1	1045	<b>No. Description</b>		0	—
2	5,000 RTJ	5	Weld			8	ASTM A351 Gr. CF8M	8	ASTM A351 Gr. CF8M	1	Buna-N and Buna-N	1	316 SS inlay <sup>†</sup>
<b>Weld</b>		7	Flanged							2	FKM and FKM	2	625 SS inlay <sup>†</sup>
1	Sch. 80	9	Hammer union										
2	XXH												
5	Sch. 160												
<b>Threaded</b>													
0	LP												
2	UPTBG												
<b>Hammer union</b>													
9	2.00-in [50-mm] XXH 1502 hammer union												

<sup>†</sup> Inlay only available on flanged valves.

Parts List

Repair Kit	Key No.	Qty.	Description	Valve Seat Port Size for 5,000-psi WP: 2 in [50 mm]	Repair Kit Component Part Numbers
			<b>Assembly Base Number — NACE Compliant</b>		
			<b>2-in [50-mm] nominal end— threaded, flanged, weld, and hammer</b>	<b>J024929</b>	
			<b>2.50-in [65-mm] nominal end— weld</b>	<b>J025205</b>	
	1	1	Body	ASTM A105 for Threaded, weld, and hammer ASTM A487 Gr. 4 Class A for Flanged	—
	2	1	Bonnet	ASTM A105	—
	3	1	Coupling	ASTM A487 Gr. 4 Class A	—
■ ●	4	1	Gate	41XX with electroless nickel plating (ENP) ASTM A351 Gr. CF8M	J001887-002 J001887-108
	5	1	Handle	ASTM A536 Gr. 65-45-12	—
	6	1	Housing	CD 1018	—
	7	1	Index pin	Steel	—
	8	1	Lock handle	CD 1213/15	—
	9	1	Lock screw	Steel	—
	10	1	Lubricating nipple, 1/8 NPT	Steel	—
■	11	1	O-ring, AS-568-210, secondary seal	Buna-N	J005526-210
■	12	1	O-ring, AS-568-224, housing seal	Buna-N	J005526-224
■ ●	13	1	O-ring, AS-568-342, bonnet seal	Buna-N FKM	J005526-342 J005531-342
	14	1	Retainer	CD 1213/15	—
■ ●	15	1	Seat assembly	1045 and Buna-N 1045 and FKM ASTM A351 Gr. CF8M and Buna-N ASTM A351 Gr. CF8M and FKM	J001876-011 J001876-012 J001876-081 J001876-082
	16	1	Split pin, 3/16 × 1 1/4	Steel	—
■	17	1	Stem	316 SS	J001931-008
■	18	1	Stem screw	CD 1213/15	J001913
■	19	1	Stem seal assembly with bushing	Buna-N and bronze FKM and bronze	JN01949-001 JN01949-006

■ Major repair kit J025216-11221— one each for one year of service.

● Minor repair kit J025216-01221.

Major and minor repair kits listed for trim option J0XXXX-XX82110 (316 SS stem, 41XX with ENP gate, and 1045 Buna-N seat and seals).

Consult Cameron for other repair kit trim options.

# Series DM gate valves — 5,000-psi WP

3-in [80-mm] seat port

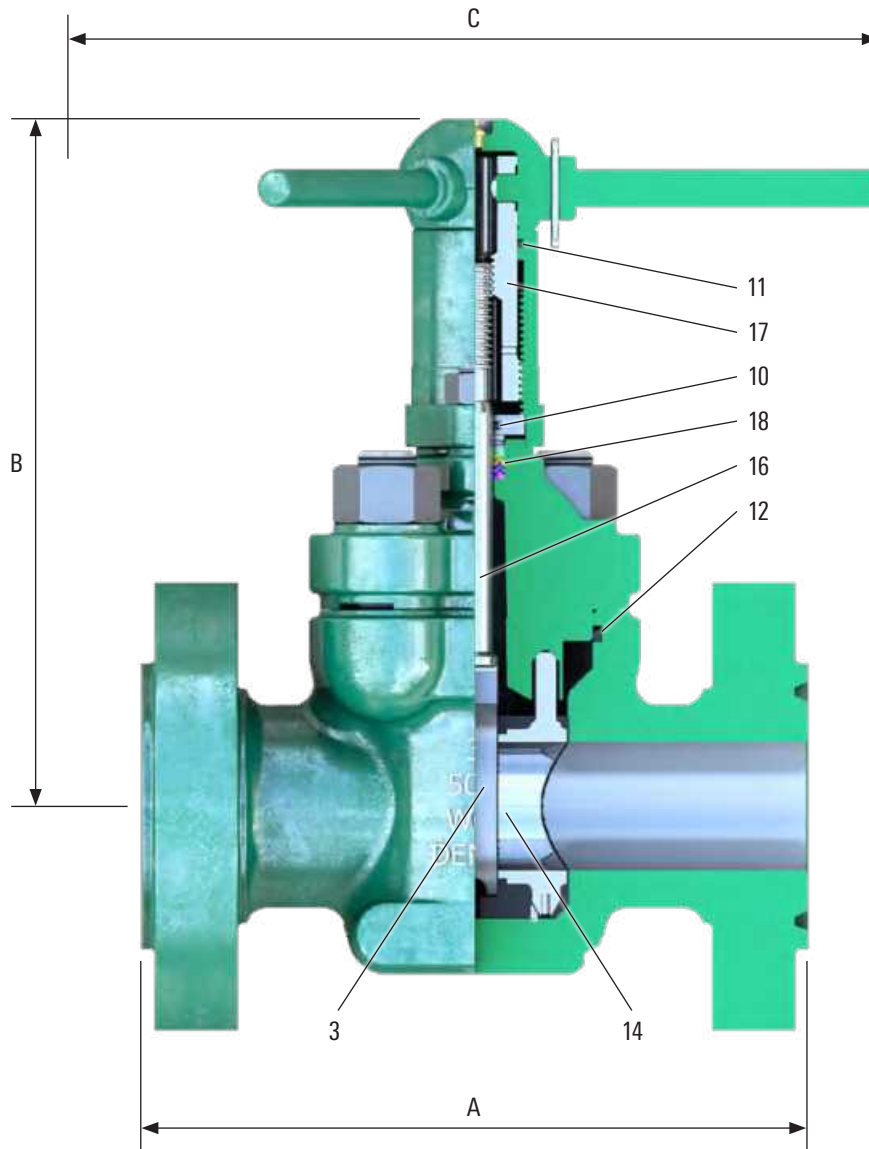

## Dimensional Data and Weights

Dimension	Valve Seat Port Size for 5,000-psi WP: 3 in [80 mm]		
A, length, in [mm]	Weld and threaded end	11.00 [279]	
	Flanged end	15.63 [397]	
	Hammer union end	4 in	16.88 [429]
		3 in	22.62 [574]
For flanged ends	API ring number	R-35	
	Flange ID, in [mm]	3.00 [80]	
	Flange OD, in [mm]	10.50 [267]	
	Flange bolts, amount; in [mm]	8; 1½ [29]	
Weight, lbm [kg]	Weld and threaded end	158 [72]	
	Flanged end	239 [109]	
	Hammer union end	4 in	178 [81]
		3 in	185 [84]
Number of handle turns from open to closed	11.0		
B, height, center to top (open), in [mm]	18.00 [457]		
C, handle diameter, in [mm]	19.00 [483]		



Assembly Part Number Example

**J025119-2788811**

Assembly Base Number

3 in [80 mm]

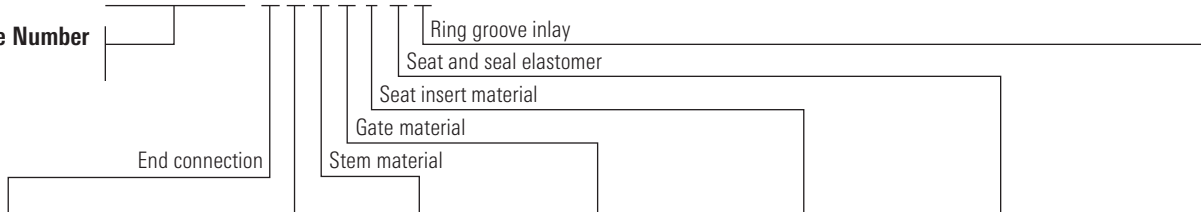

End Connection		Body Configuration		Stem Material		Gate Material		Seat Insert Material		Seat and Seal Elastomer		Ring Groove Inlay	
No.	Description	No.	Description	No.	Description	No.	Description	No.	Description	No.	Description	No.	Description
<b>Flanged</b>													
2	5,000 RTJ	4	Threaded	8	316 SS	2	41XX	1	1045	1	Buna-N and Buna-N	0	-
<b>Weld</b>													
1	Sch. 80	5	Weld			8	ASTM A351 Gr. CF8M	8	ASTM A351 Gr. CF8M	2	FKM and FKM	1	316 SS inlay <sup>†</sup>
2	XXH	7	Flanged									2	625 SS inlay <sup>†</sup>
5	Sch. 160	9	Hammer union										
<b>Threaded</b>													
0	LP												
1	TBS												
<b>Hammer union</b>													
8	3.00-in [50-mm] XXH 1502 hammer union												
9	4.00-in [100-mm] XXH 1502 hammer union												

<sup>†</sup> Inlay only available on flanged valves.

Parts List

Repair Kit	Key No.	Qty.	Description	Valve Seat Port Size for 5,000-psi WP: 3 in [80 mm]	Repair Kit Component Part Numbers
			<b>Assembly Base Number — NACE Compliant</b>		
			<b>3-in [80-mm] nominal end— threaded, flanged, weld, and hammer</b>	<b>J025119</b>	
			<b>4-in [100-mm] nominal end— weld</b>	<b>J025116</b>	
	1	1	Body	ASTM A487 Gr. 4 Class D	-
	2	1	Bonnet	ASTM A487 Gr. 4 Class D	-
■ ●	3	1	Gate	41XX with ENP	J001886-002
				ASTM A351 Gr. CF8M	J001886-108
	4	1	Handle	ASTM A536 Gr. 65-45-12	-
	5	4	Heavy hex nut, 1 $\frac{1}{8}$ -8 UN	ASTM A194 Gr. 2H	-
	6	2	Heavy hex nut, $\frac{3}{4}$ -10 UNC	ASTM A194 Gr. 2H	-
	7	1	Housing	ASTM A350 Gr. LF2 Class 1	-
	8	1	Lock handle	CD 1213/15	-
	9	1	Lubricating nipple, $\frac{1}{2}$ NPT	Steel	-
■	10	1	O-ring, AS-568-212, secondary seal	Buna-N	J005526-212
■	11	1	O-ring, AS-568-226, housing seal	Buna-N	J005526-226
■ ●	12	1	O-ring, AS-568-433, bonnet seal	Buna-N	J005526-433
				FKM	J005531-433
	13	1	Retainer	CD 1213/15	-
■ ●	14	1	Seat assembly	1045 and Buna-N	J001878-011
				1045 and FKM	J001878-012
				ASTM A351 Gr. CF8M and Buna-N	J001878-081
				ASTM A351 Gr. CF8M and FKM	J001878-082
	15	1	Split pin, $\frac{3}{16}$ × 1 $\frac{1}{4}$	Steel	-
■	16	1	Stem	316 SS	J001932-008
■	17	1	Stem screw	CD 1213/15	J001914-003
■	18	1	Stem seal assembly with bushing	Buna-N and bronze	JN01950-001
				FKM and bronze	JN01950-006
	19	2	Stud (continuous), $\frac{3}{4}$ -10 UNC × 2.88 (long)	ASTM A193 Gr. B7	-
	20	4	Stud (double ended), 1 $\frac{1}{8}$ -8 UN × 5.25 (long)	ASTM A193 Gr. B7	-

■ Major repair kit J025216-12221 — one each for one year of service.

● Minor repair kit J025216-02221.

Major and minor repair kits listed for trim option J0XXXX-XX82110 (316 SS stem, 41XX with ENP gate, and 1045 Buna-N seat and seals).

Consult Cameron for other repair kit trim options.

# Series DM gate valves — 5,000-psi WP

4-in [100-mm] seat port

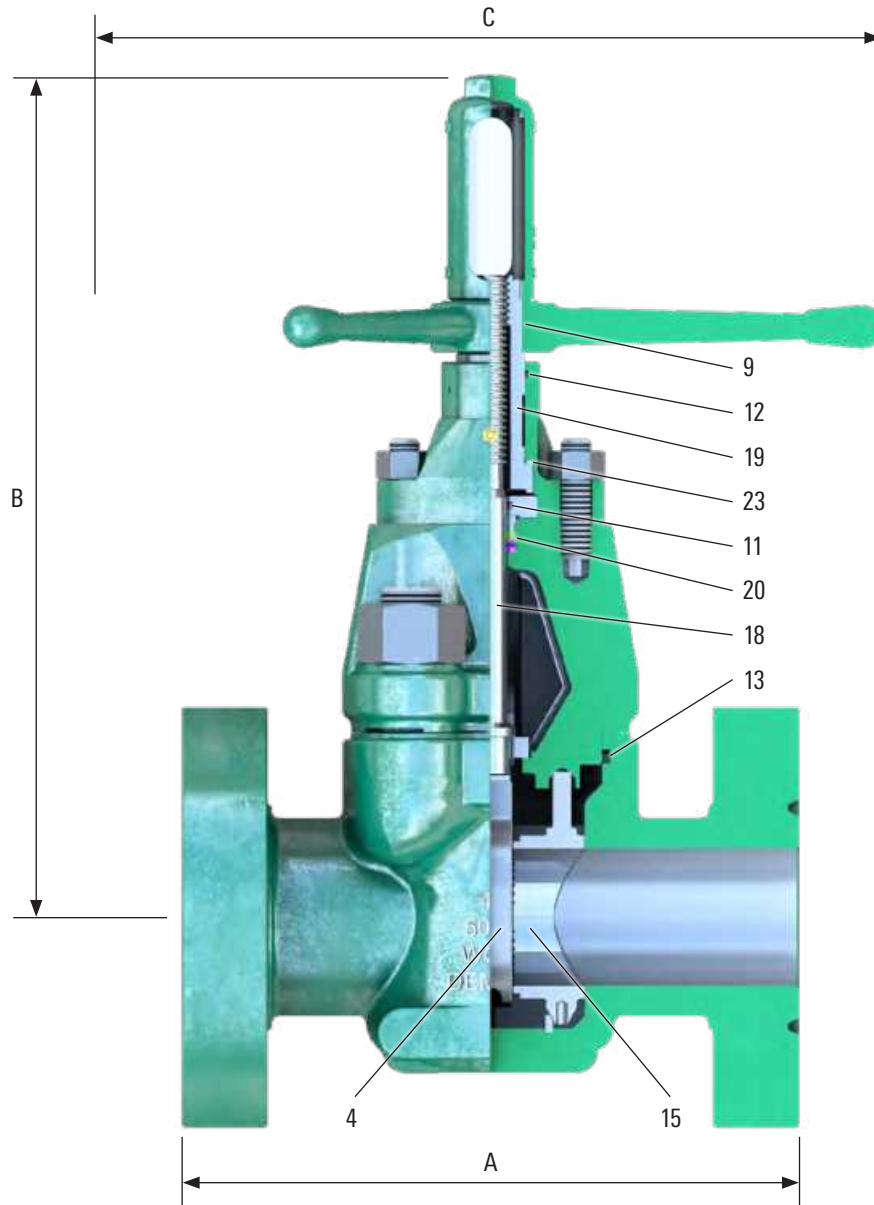

## Dimensional Data and Weights

Dimension	Valve Seat Port Size for 5,000-psi WP: 4 in [100 mm]		
A, length, in [mm]	Weld and threaded end	13.00 [330]	
	Flanged end	18.00 [457]	
	Hammer union end	5 in	22.62 [574]
		4 in	24.62 [625]
For flanged ends	API ring number	R-39	
	Flange ID, in [mm]	4.00 [100]	
	Flange OD, in [mm]	12.25 [311]	
	Flange bolts, amount; in [mm]	8; 1¼ [32]	
Weight, lbm [kg]	Weld and threaded end	236 [107]	
	Flanged end	373 [169]	
	Hammer union end	5 in	332 [151]
		4 in	328 [149]
Number of handle turns from open to closed	22.9		
B, height, center to top (open), in [mm]	24.57 [624]		
C, handle diameter, in [mm]	23.00 [584]		



Assembly Part Number Example

**J025206-2782121**

Assembly Base Number

4 in [100 mm]

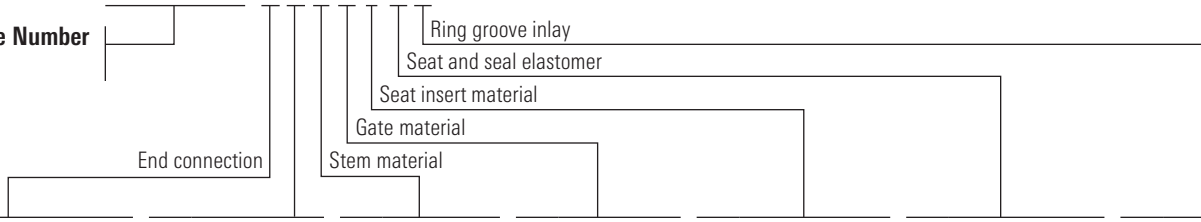

End Connection		Body Configuration		Stem Material		Gate Material		Seat Insert Material		Seat and Seal Elastomer		Ring Groove Inlay	
No.	Description	No.	Description	No.	Description	No.	Description	No.	Description	No.	Description	No.	Description
<b>Flanged</b>													
2	5,000 RTJ	4	Threaded	8	316 SS	2	41XX	1	1045	1	Buna-N and Buna-N	0	—
<b>Weld</b>													
1	Sch. 80	5	Weld			8	ASTM A351 Gr. CF8M	8	ASTM A351 Gr. CF8M	2	FKM and FKM	1	316 SS inlay <sup>†</sup>
2	XXH	7	Flanged									2	625 SS inlay <sup>†</sup>
5	Sch. 160	9	Hammer union										
<b>Threaded</b>													
0	LP												
1	TBS												
<b>Hammer union</b>													
8	4.00-in [100-mm] XXH 1502 hammer union												
9	5.00-in [125-mm] XXH 1502 hammer union												

<sup>†</sup> Inlay only available on flanged valves.

Parts List

Repair Kit	Key No.	Qty.	Description	Valve Seat Port Size for 5,000-psi WP: 4 in [100 mm]	Repair Kit Component Part Numbers
<b>Assembly Base Number — NACE Compliant</b>					
<b>4-in [100-mm] nominal end—threaded, flanged, weld, and hammer</b>				<b>J025206</b>	
<b>5-in [125-mm] nominal end—weld and hammer</b>				<b>J025118</b>	
<b>6-in [150-mm] nominal end—weld</b>				<b>J025220</b>	
	1	1	Body	ASTM A487 Gr. 4 Class D	—
	2	1	Bonnet	ASTM A487 Gr. 4 Class D	—
	3	1	Downstop ring	303 SS	—
■	4	1	Gate	41XX with ENP	J001926-002
				ASTM A351 Gr. CF8M	J001926-108
	5	1	Handle	ASTM A536 Gr. 65-45-12	—
	6	4	Heavy hex nut, 1¼ special	ASTM A194 Gr. 2H	—
	7	2	Heavy hex nut, ¾-9 UNC	ASTM A194 Gr. 2H	—
	8	1	Housing	HR 1018	—
■	9	1	Key	Steel	J005305-10016
	10	1	Lubricating nipple, ½ NPT	Steel	—
■	11	1	O-ring, AS-568-214, secondary seal	Buna-N	J005526-214
■	12	1	O-ring, AS-568-226, housing seal	Buna-N	J005526-226
■	13	1	O-ring, AS-568-439, bonnet seal	Buna-N	J005520-439
				FKM	J005531-439
	14	1	Retainer	CD 1213/15	—
■	15	1	Seat assembly	1045 and Buna-N	J002207-021
				1045 and FKM	J002207-022
				ASTM A351 Gr. CF8M and Buna-N	J002207-081
				ASTM A351 Gr. CF8M and FKM	J002207-082
	16	1	Sight tube	Clear acrylic	—
	17	1	Stem cap	ASTM A536 Gr. 65-45-12	—
■	18	1	Stem	316 SS	J007439-008
■	19	1	Stem screw	CD 1213/15	J007416
■	20	1	Stem seal assembly with bushing	Buna-N and bronze	JN01951-001
				FKM and bronze	JN01951-006
	21	2	Stud (continuous), ¾-9 UN × 3.50 (long)	ASTM A193 Gr. B7	—
	22	4	Stud (double ended), 1¼ special × 6.00 (long)	ASTM A193 Gr. B7	—
■	23	2	Thrust washer	Teflon and phenolic material	J007426

■ Major repair kit J025216-14221—one each for one year of service.

● Minor repair kit J025216-04221.

Major and minor repair kits listed for trim option J0XXXX-XX82110 (316 SS stem, 41XX with ENP gate, and 1045 Buna-N seat and seals).

Consult Cameron for other repair kit trim options.

# Series DM gate valves — 5,000-psi WP

## 5.12-in [130-mm] seat port

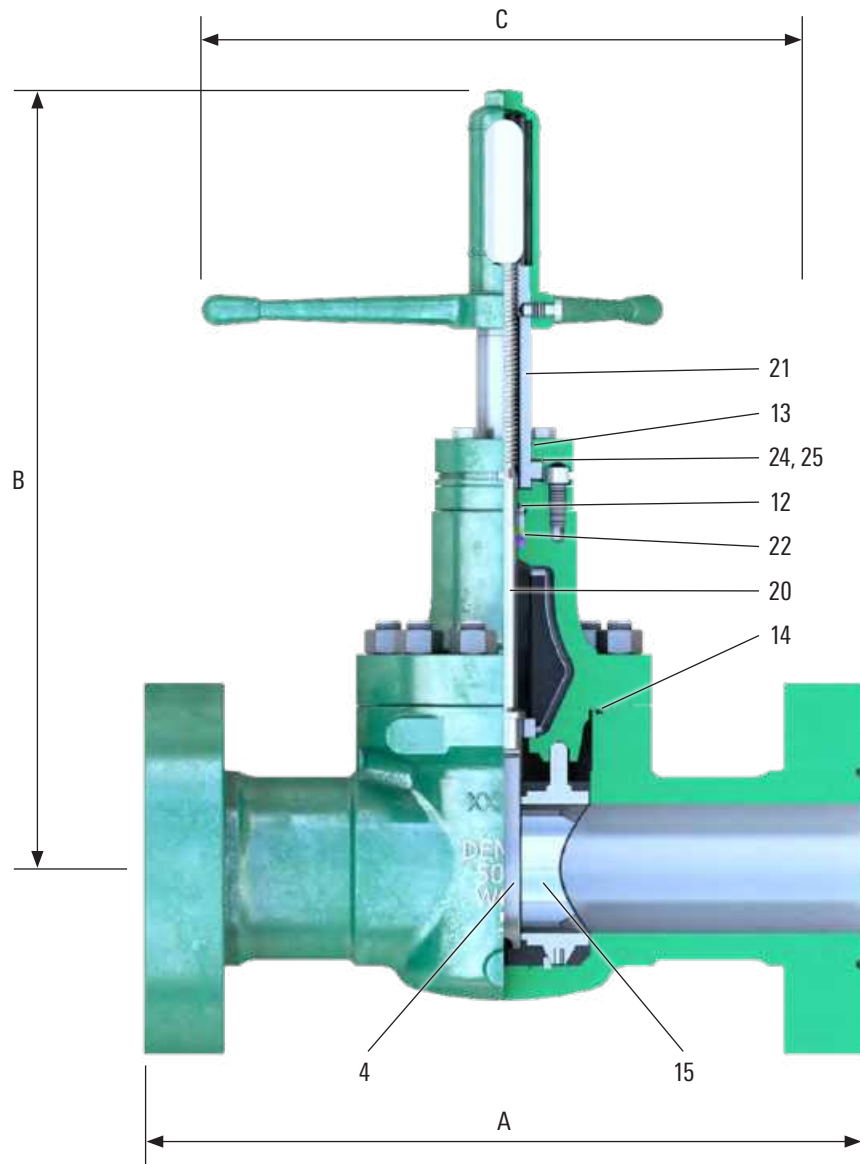

### Dimensional Data and Weights

Dimension	Valve Seat Port Size for 5,000-psi WP: 5.12 in [130 mm]	
A, length, in [mm]	Weld and threaded end	16.00 [406]
	Flanged end	28.62 [727]
For flanged ends	API ring number	R-44
	Flange ID, in [mm]	5.12 [130]
	Flange OD, in [mm]	14.75 [375]
	Flange bolts, amount; in [mm]	8; 1½ [38]
Weight, lbm [kg]	Weld end	329 [149]
	Flanged end	611 [277]
Number of handle turns from open to closed	29.6	
B, height, center to top (open), in [mm]	30.93 [786]	
C, handle diameter, in [mm]	24.00 [610]	



Assembly Part Number Example

**J025317-7788120**

Assembly Base Number

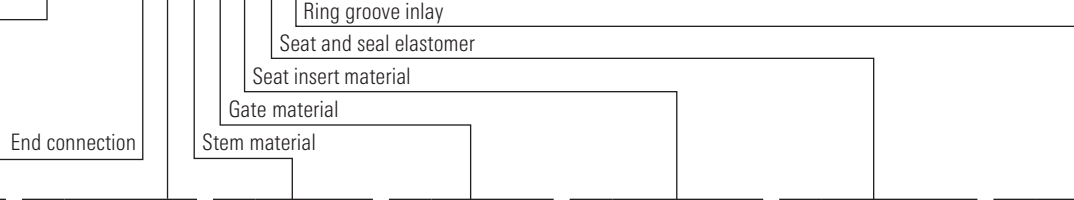

End Connection		Body Configuration		Stem Material		Gate Material		Seat Insert Material		Seat and Seal Elastomer		Ring Groove Inlay	
No.	Description	No.	Description	No.	Description	No.	Description	No.	Description	No.	Description	No.	Description
<b>Flanged</b>													
7	5,000 RTJ	4	Threaded	8	17-4PH SS	2	41XX	1	1045	<b>No. Description</b>		0	—
<b>Weld</b>													
2	XXH	5	Weld			8	ASTM A487 Gr. CA15 Class C	8	ASTM A487 Gr. CA15 Class C	1	Buna-N and Buna-N	1	316 SS inlay <sup>†</sup>
5	Sch. 160	7	Flanged							2	FKM and FKM	2	625 SS inlay <sup>†</sup>
<b>Threaded</b>													
3	LC												

<sup>†</sup> Inlay only available on flanged valves.

Parts List

Repair Kit	Key No.	Qty.	Description	Valve Seat Port Size for 5,000-psi WP: 5.12 in [130 mm]		Repair Kit Component Part Numbers
				Assembly Base Number — NACE Compliant		
			<b>5-in [125-mm] nominal end—threaded and flanged</b>		<b>J025317</b>	
			<b>6-in [150-mm] nominal end—weld</b>		<b>J025326</b>	
	1	1	Body	ASTM A487 Gr. 4 Class D		—
	2	1	Bonnet	ASTM A487 Gr. 4 Class D		—
	3	1	Downstop ring	303 SS		—
	4	4	Capscrew socket head, 5/8 UNC × 1.75 (long)	ASTM A574 Alloy Steel		—
■ ●	5	1	Gate	41XX with ENP		J021952-002
				ASTM A487 Gr. CA15 Class C		J021952-108
	6	1	Handle	ASTM A536 Gr. 65-45-12		—
	7	1	Handle screw	CD 1018/26		—
	8	12	Heavy hex nut, 1-8 UNC	ASTM A194 Gr. 2H		—
	9	4	Hex head bolt, 5/8-11 UNC × 3.50 (long)	SAE steel Gr. 2		—
	10	1	Housing	HR 1018/22		—
	11	1	Lubricating nipple, 1/8 NPT	Steel		—
■	12	1	O-ring, AS-568-216, secondary seal	Buna-N		J005526-216
■	13	1	O-ring, AS-568-228, housing seal	Buna-N		J005526-228
■ ●	14	1	O-ring, AS-568-367, bonnet seal	Buna-N		J005520-367
				FKM		J005531-367
	15	1	Relief fitting, 1/8 NPT	Steel		—
	16	1	Retainer	HR 1018/22		—
■ ●	17	1	Seat assembly	1045 and Buna-N		J021948-019
				1045 and FKM		J021948-012
				ASTM A487 Gr. CA15 Class C and Buna-N		J021948-099
				ASTM A487 Gr. CA15 Class C and FKM		J021948-092
	18	1	Sight tube	Clear acrylic		—
	19	1	Stem cap	ASTM A536 Gr. 65-45-12		—
■	20	1	Stem	17-4PH SS		J021943-009
■	21	1	Stem screw	CD 1018/26		J019159
■	22	1	Stem seal assembly with bushing	Buna-N and bronze		J015853-001
				FKM and bronze		J015853-006
	23	12	Stud (double ended), 1-8 UNC × 4.50 (long)	ASTM A193 Gr. B7		—
■	24	2	Thrust needle roller bearing	Hardened steel		J050911-005
■	25	4	Thrust washer	Hardened steel		J050911-006

■ Major repair kit J025216-15221 — one each for one year of service.

● Minor repair kit J025216-05221.

Major and minor repair kits listed for trim option J0XXXXX-XX82110 (17-4PH SS stem, 41XX with ENP gate, and 1045 Buna-N seat and seals).

Consult Cameron for other repair kit trim options.

# Series DM gate valves—ASME Class 600

1.62- to 6-in [40- to 150-mm] seat port

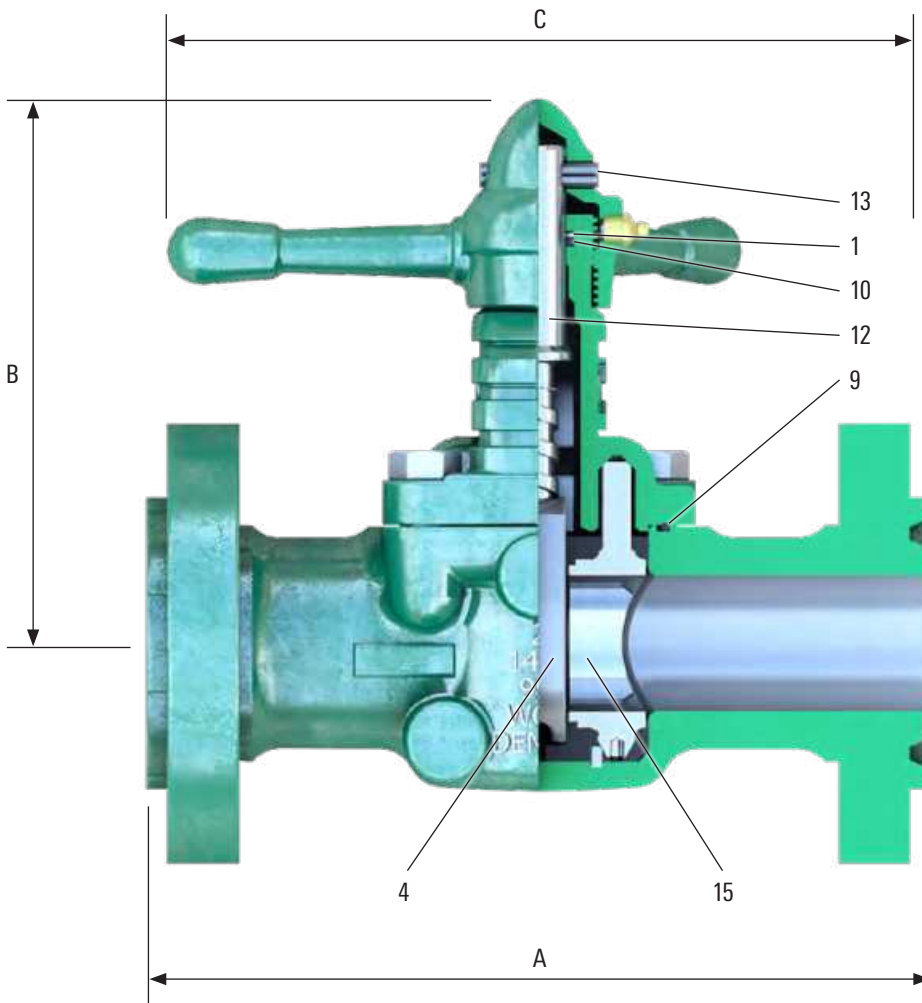

## Dimensional Data and Weights

Dimension		Valve Seat Port Sizes for ASME 600 Class, in [mm]						
		1.62 [40] with 1.50 [40] Threaded Ends	2 [50]	2.50 [65]	3 [80]	4 [100]	6 [150]	6 [150] with 8 [200] Flanges
A, length, in [mm]	Weld, threaded, and grooved end	7.75 [197]	8.88 [226]	10.00 [254]	10.25 [260]	11.88 [302]	15.50 [394]	—
	Flanged RF end	—	11.50 [292]	13.00 [330]	14.00 [356]	17.00 [432]	22.00 [559]	26.00 [660]
	Flanged RTJ end	—	11.62 [295]	13.12 [333]	14.12 [359]	17.12 [435]	22.12 [562]	26.12 [663]
For flanged ends	API ring number	—	R-23	R-26	R-31	R-37	R-45	R-49
	Flange ID, in [mm]	—	2.00 [50]	2.50 [65]	3.00 [80]	4.00 [100]	6.00 [150]	8.00 [200]
	Flange OD, in [mm]	—	6.50 [165]	7.50 [191]	8.25 [210]	10.75 [273]	14.00 [356]	16.50 [419]
	Flange bolts, amount; in [mm]	—	8; 5/8 [16]	8; 3/4 [19]	8; 3/4 [19]	8; 7/8 [22]	12; 1 [25]	12; 1 1/8 [29]
Weight, lbm [kg]	Weld, threaded, and grooved end	20 [9]	26 [12]	50 [23]	60 [27]	98 [44]	310 [141]	—
	Flanged end	—	44 [20]	74 [34]	96 [44]	176 [80]	428 [194]	590 [268]
B, height, center to top (open), in [mm]		7.75 [197]	8.75 [222]	10.62 [270]	11.38 [289]	13.88 [353]	19.25 [489]	19.25 [489]
C, handle diameter, in [mm]		9.50 [241]	11.00 [279]	12.62 [321]	12.62 [321]	14.25 [362]	24.00 [610]	24.00 [610]

Assembly Part Number Example

**J001072-2722110**

Assembly Base Number

2 in [50 mm]

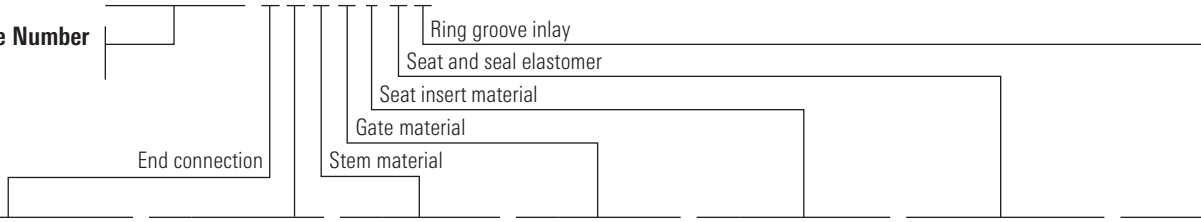

End Connection		Body Configuration		Stem Material		Gate Material		Seat Insert Material		Seat and Seal Elastomer		Ring Groove Inlay	
No.	Description	No.	Description	No.	Description	No.	Description	No.	Description	No.	Description	No.	Description
<b>Flanged</b>		4	Threaded	2	303 SS	2	1045	1	1045	<b>No. Description</b>		0	–
2	600 RTJ	5	Weld	8	316 SS	8	ASTM A351 Gr. CF8M	8	ASTM A351 Gr. CF8M	1	Buna-N and Buna-N	1	316 SS inlay <sup>†</sup>
3	600 RF	6	Grooved							2	FKM and FKM	2	625 SS inlay <sup>†</sup>
<b>Weld</b>		7	Flanged										
0	Sch. 40												
<b>Threaded</b>													
0	LP												
1	TBG												
2	UPTBG												
<b>Grooved</b>													
0	Sch. 80												

<sup>†</sup> Inlay only available on flanged valves.

Parts List

Key No.	Qty.	Description	Valve Seat Port Sizes for ASME 600 Class, in [mm]					6 [150]	6 [150] with 8 [200] Flanges	
			1.62 [40] with 1.50 [40] Threaded Ends	2 [50]	2.50 [65]	3 [80]	4 [100]			
<b>Assembly base number</b>										
		Threaded	J003938	J001072	J001074	J001076	J001078	J001080	–	
		Weld	–	J001092	J001094	J001096	J001098	J001100	–	
		Grooved	–	J001082	J001084	J001086	J001088	J001090	–	
		Flanged	–	J001062	J001064	J001066	J001068	J001070	J003945	
1 <sup>†</sup>	1	Backup ring	Chrome leather							
2	1	Body	ASTM A216 Gr. WCB							
3	1	Bonnet	ASTM A216 Gr. WCB							
4 <sup>†</sup>	1	Gate	1045 with ENP							
			ASTM A351 CF8M							
5	1	Handle	ASTM A536 Gr. 65-45-12							
6	4	Heavy hex nut, body	–				ASTM A194 Gr. 2H			
7	4	Hex head bolt, body	SAE Gr. 5				Na			
8	1	Lubricating nipple, 1/8 NPT					Steel			
9 <sup>†</sup>	1	O-ring, bonnet seal					Buna-N			
							FKM			
10 <sup>†</sup>	1	O-ring, stem seal					Buna-N			
							FKM			
11 <sup>†</sup>	1	Seat assembly					1045 and Buna-N			
							1045 and FKM			
							ASTM A351 Gr. CF8M and Buna-N			
							ASTM A351 Gr. CF8M and FKM			
12 <sup>†</sup>	1	Stem					303 SS			
							316 SS			
13 <sup>†</sup>	1	Stem pin					Spring steel			
14	4	Stud (double ended), body	–				ASTM A193 Gr. B7			

<sup>†</sup> Recommended spare parts. Contact Cameron for specific part numbers.

# Series DM gate valves—ASME Class 900

2- to 6-in [50- to 150-mm] seat port

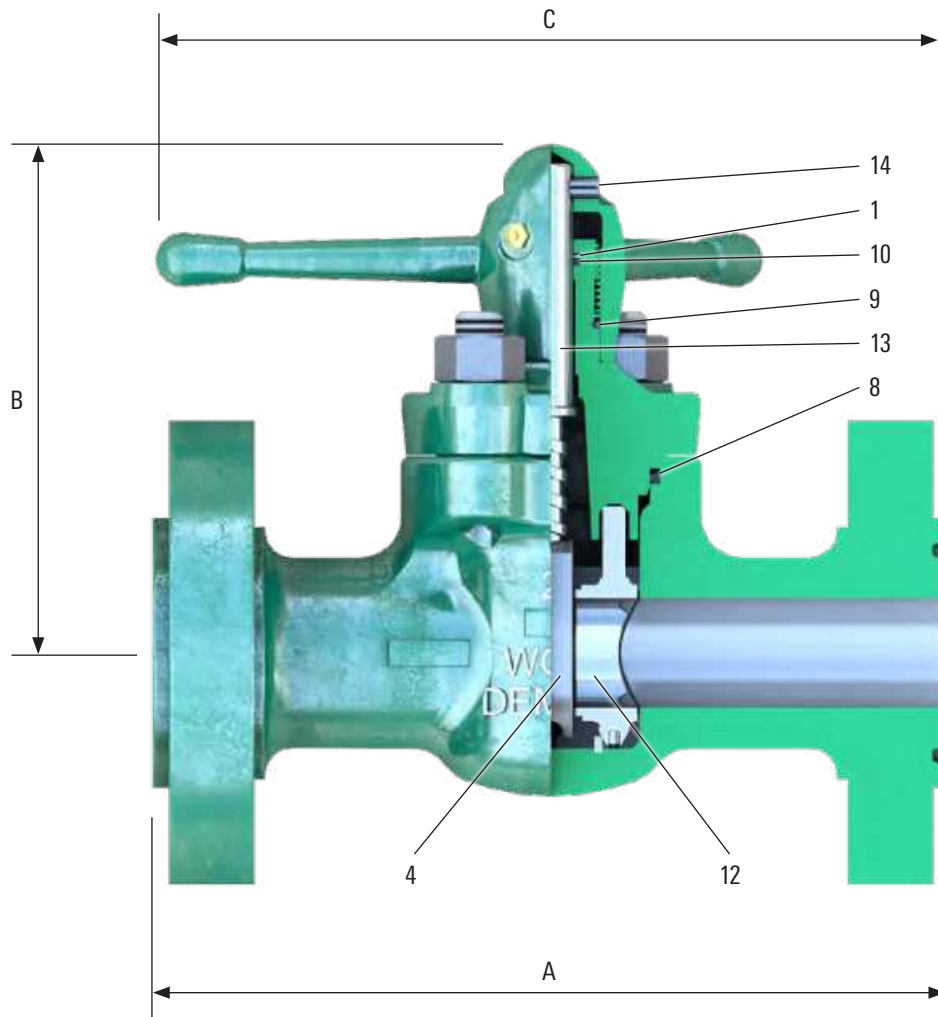

## Dimensional Data and Weights

Dimension		Valve Seat Port Sizes for ASME 900 Class, in [mm]				
		2 [50]	2.50 [65]	3 [80]	4 [100]	6 [150]
A, length, in [mm]	Weld, threaded, and grooved end	9.00 [229]	9.75 [248]	11.00 [279]	13.00 [330]	20.00 [508]
	Flanged RF end	14.50 [368]	16.50 [419]	15.00 [381]	18.00 [457]	24.00 [610]
	Flanged RTJ end	14.62 [371]	16.62 [422]	15.12 [384]	18.12 [460]	24.12 [613]
For flanged ends	API ring number	R-24	R-27	R-31	R-37	R-45
	Flange ID, in [mm]	2.00 [50]	2.50 [65]	3.00 [80]	4.00 [100]	6.00 [150]
	Flange OD, in [mm]	8.50 [216]	9.62 [244]	9.50 [241]	11.50 [292]	15.00 [381]
	Flange bolts, amount; in [mm]	8; 7/8 [22]	8; 1 [25]	8; 7/8 [22]	8; 1 1/8 [19]	12; 1 1/8 [19]
Weight, lbm [kg]	Weld, threaded, and grooved end	48 [22]	87 [39]	95 [43]	140 [64]	325 [147]
	Flanged end	100 [45]	170 [77]	160 [73]	230 [104]	540 [245]
B, height, center to top (open), in [mm]		9.88 [251]	22.88 [581]	12.75 [324]	15.00 [381]	19.25 [489]
C, handle diameter, in [mm]		14.50 [368]	19.00 [483]	19.00 [483]	23.00 [584]	24.00 [610]

Assembly Part Number Example

**J003947-4 7 8 2 1 1 2**

Assembly Base Number

2 in [50 mm]

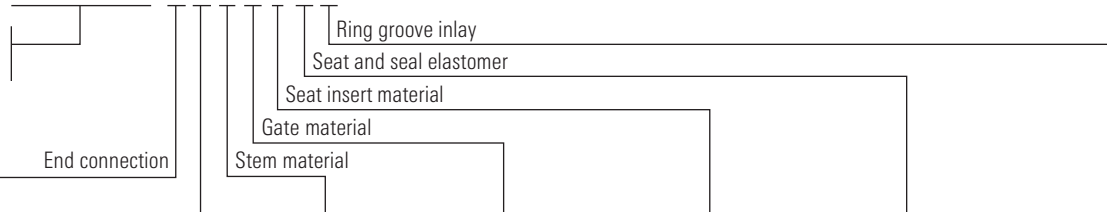

End Connection		Body Configuration		Stem Material		Gate Material		Seat Insert Material		Seat and Seal Elastomer		Ring Groove Inlay	
No.	Description	No.	Description	No.	Description	No.	Description	No.	Description	No.	Description	No.	Description
<b>Flanged</b>													
4	900 RTJ	4	Threaded	2	303 SS	2	1045	1	1045	1	Buna-N and Buna-N	0	–
5	900 RF	5	Weld	8	316 SS	8	ASTM A351 Gr. CF8M	8	ASTM A351 Gr. CF8M	2	FKM and FKM	1	316 SS inlay <sup>†</sup>
<b>Weld</b>													
0	Sch. 40	6	Grooved										
1	Sch. 80	7	Flanged										
<b>Threaded</b>													
0	LP												
1	TBG												
2	UPTBG												
<b>Grooved</b>													
0	Sch. 80												

<sup>†</sup> Inlay only available on flanged valves.

Parts List

Key No.	Qty.	Description	Valve Seat Port Sizes for ASME 900 Class, in [mm]				
			2 [50]	2.50 [65]	3 [80]	4 [100]	6 [150]
<b>Assembly Base Number—General Service</b>			<b>J003947</b>	<b>J003951</b>	<b>J003953</b>	<b>J003955</b>	<b>J003999</b>
1 <sup>†</sup>	1	Backup ring	Chrome leather				
2	1	Body	ASTM A487 Gr. 4 Class A				
3	1	Bonnet	ASTM A487 Gr. 4 Class A				
4 <sup>†</sup>	1	Gate	1045 with ENP				
			ASTM A351 CF8M				
5	1	Handle	ASTM A536 Gr. 65-45-12				
6	4	Heavy hex nut, body	ASTM A194 Gr. 2H				
7	1	Lubricating nipple, 1/8 NPT	Steel				
8 <sup>†</sup>	1	O-ring, bonnet seal	Buna-N				
			FKM				
9 <sup>†</sup>	1	O-ring, screw seal	Buna-N				
10 <sup>†</sup>	1	O-ring, stem seal	Buna-N				
			FKM				
			Steel				
11	1	Relief fitting, 1/8 NPT					
12 <sup>†</sup>	1	Seat assembly	1045 and Buna-N				
			1045 and FKM				
			ASTM A351 Gr. CF8M and Buna-N				
			ASTM A351 Gr. CF8M and FKM				
13 <sup>†</sup>	1	Stem	303 SS				
			316 SS				
14 <sup>†</sup>	1	Stem pin	Spring steel				
15	4	Stud (double ended), body	ASTM A193 Gr. B7				

<sup>†</sup> Recommended spare parts. Contact Cameron for specific part numbers.

# Series DM gate valves—ASME Class 1500

2- to 3-in [50- to 80-mm] seat port

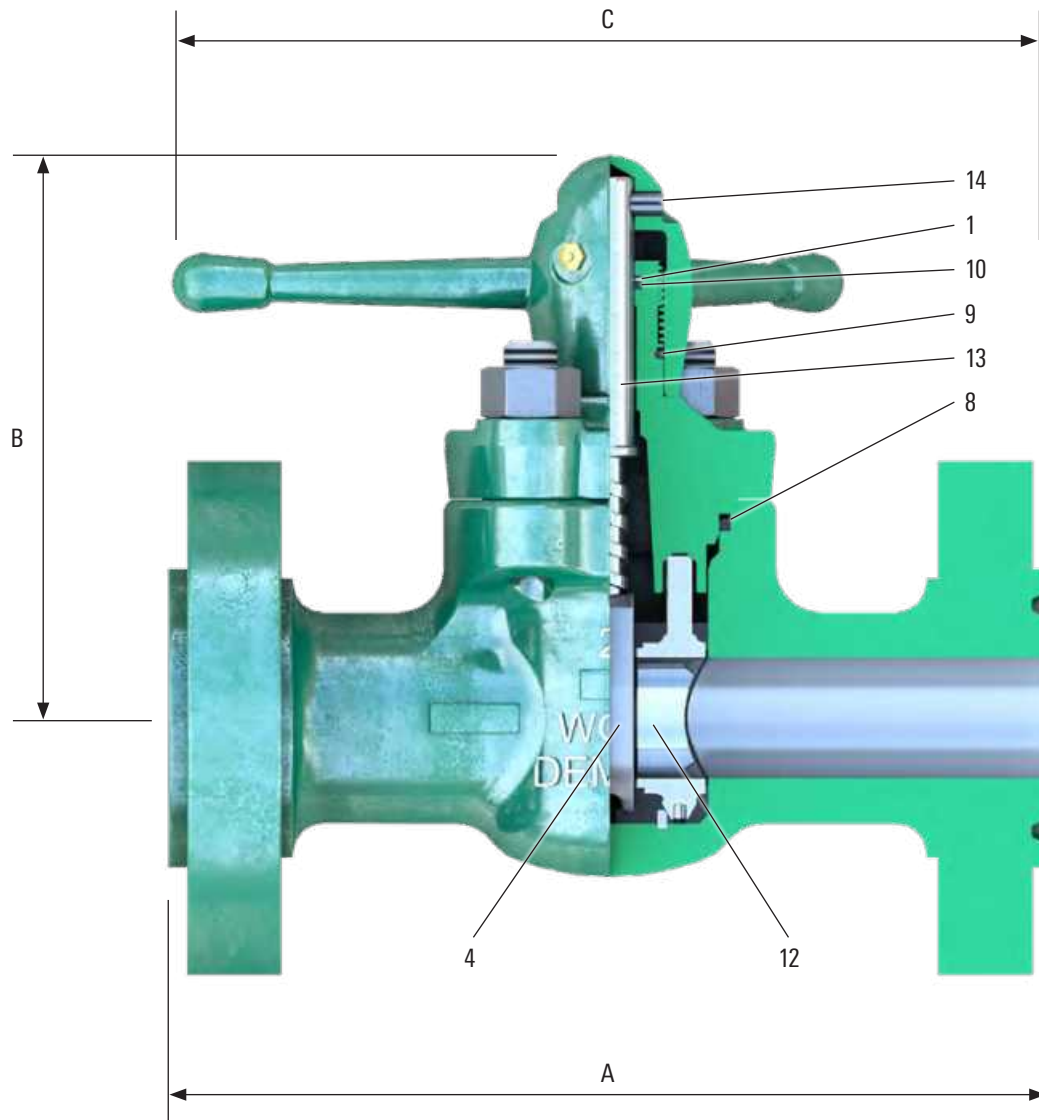

## Dimensional Data and Weights

Dimension		Valve Seat Port Sizes for ASME 1500 Class, in [mm]		
		2 [50]	2.50 [65]	3 [80]
A, length, in [mm]	Weld, threaded, and grooved end	9.00 [229]	9.75 [248]	11.00 [279]
	Flanged RF end	14.50 [368]	16.50 [419]	18.50 [470]
	Flanged RTJ end	14.62 [371]	16.62 [422]	18.62 [473]
For flanged ends	API ring number	R-24	R-27	R-35
	Flange ID, in [mm]	2.00 [50]	2.50 [65]	3.00 [80]
	Flange OD, in [mm]	8.50 [216]	9.62 [244]	10.50 [267]
	Flange bolts, amount; in [mm]	8; 7/8 [22]	8; 1 [25]	8; 1 1/8 [29]
Weight, lbm [kg]	Weld, threaded, and grooved end	48 [22]	87 [39]	113 [51]
	Flanged end	100 [45]	170 [77]	205 [93]
B, height, center to top (open), in [mm]		9.88 [25]	22.88 [581]	12.75 [324]
C, handle diameter, in [mm]		14.50 [368]	19.00 [483]	19.00 [483]



Assembly Part Number Example

**J003948-6 7 2 8 8 1 1**

Assembly Base Number  
2 in [50 mm], flanged

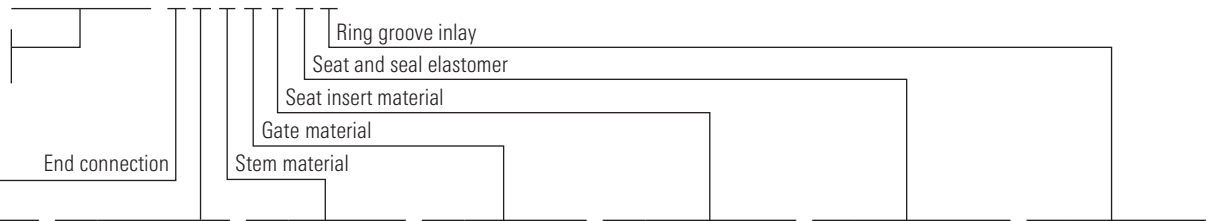

End Connection		Body Configuration		Stem Material		Gate Material		Seat Insert Material		Seat and Seal Elastomer		Ring Groove Inlay	
No.	Description	No.	Description	No.	Description	No.	Description	No.	Description	No.	Description	No.	Description
<b>Flanged</b>		4	Threaded	2	303 SS	2	1045	1	1045	<b>No. Description</b>		0	—
6	1500 RTJ	5	Weld	8	316 SS	8	ASTM A351 Gr. CF8M	8	ASTM A351 Gr. CF8M	1	Buna-N and Buna-N	1	316 SS inlay <sup>†</sup>
7	1500 RF	6	Grooved							2	FKM and FKM	2	625 SS inlay <sup>†</sup>
<b>Weld</b>		7	Flanged										
0	Sch. 40												
1	Sch. 80												
5	Sch. 160												
<b>Threaded</b>													
0	LP												
1	TBG												
2	UPTBG												
<b>Grooved</b>													
0	Sch. 80												

<sup>†</sup> Inlay only available on flanged valves.

Parts List

Key No.	Qty.	Description	Valve Seat Port Sizes for ASME 1500 Class, in [mm]		
			2 [50]	2.50 [65]	3 [80]
<b>Assembly Base Number—General Service</b>			<b>J003948</b>	<b>J003952</b>	<b>J003957</b>
1 <sup>†</sup>	1	Backup ring	Chrome leather		
2	1	Body	ASTM A487 Gr. 4 Class A		
3	1	Bonnet	ASTM A487 Gr. 4 Class A		
4 <sup>†</sup>	1	Gate	1045 with ENP		
			ASTM A351 CF8M		
5	1	Handle	ASTM A536 Gr. 65-45-12		
6	4	Heavy hex nut, body	ASTM A194 Gr. 2H		
7	1	Lubricating nipple, 1/8 NPT	Steel		
8 <sup>†</sup>	1	O-ring, bonnet seal	Buna-N		
			FKM		
9 <sup>†</sup>	1	O-ring, screw seal	Buna-N		
10 <sup>†</sup>	1	O-ring, stem seal	Buna-N		
			FKM		
11	1	Relief fitting, 1/8 NPT	Steel		
12 <sup>†</sup>	1	Seat assembly	1045 and Buna-N		
			1045 and FKM		
			ASTM A351 Gr. CF8M and Buna-N		
			ASTM A351 Gr. CF8M and FKM		
13 <sup>†</sup>	1	Stem	303 SS		
			316 SS		
14 <sup>†</sup>	1	Stem pin	Spring steel		
15	4	Stud (double ended), body	ASTM A193 Gr. B7		

<sup>†</sup> Recommended spare parts. Contact Cameron for specific part numbers.

# Series DM gate valves—ASME Class 1500

4-in [100-mm] seat port

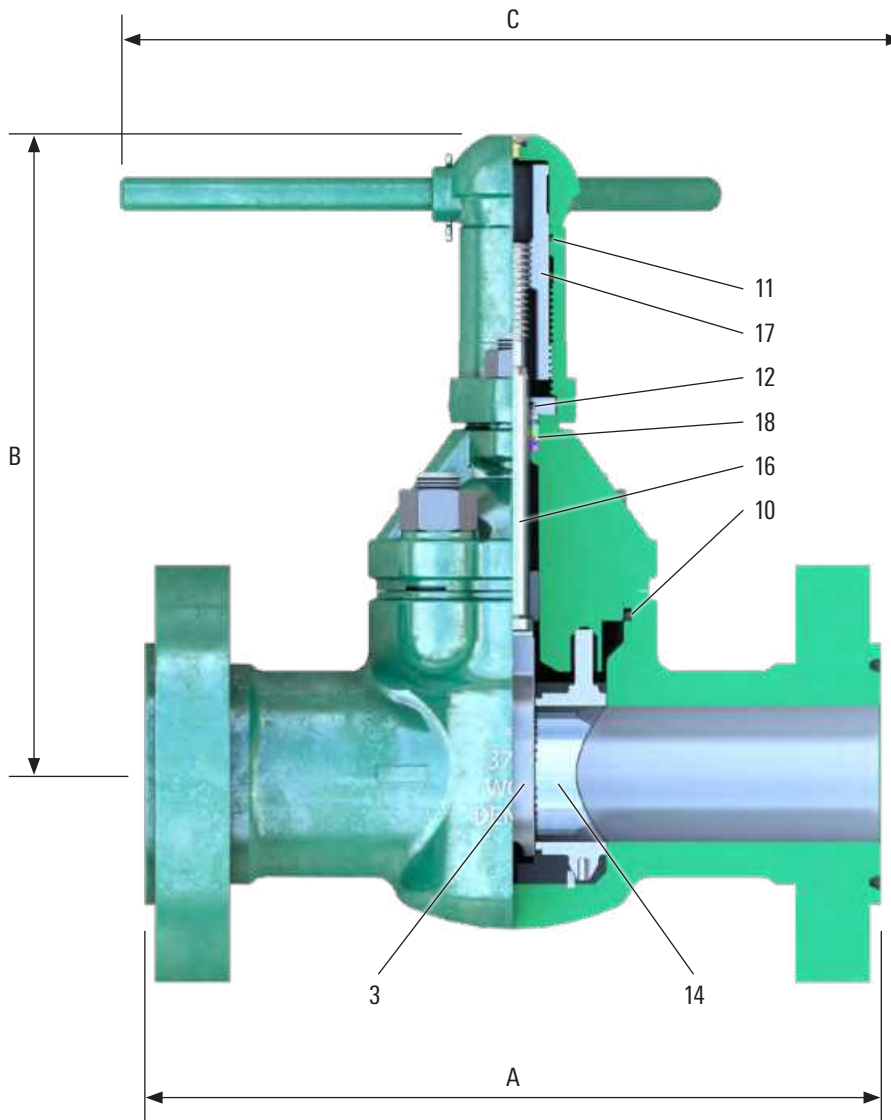

## Dimensional Data and Weights

Dimension	Valve Seat Port Size for ASME 1500 Class: 4 in [100 mm]	
A, length, in [mm]	Weld, and threaded end	13.00 [330]
	Flanged RF end	21.50 [546]
	Flanged RTJ end	21.62 [549]
For flanged ends	API ring number	R-39
	Flange ID, in [mm]	4.00 [100]
	Flange OD, in [mm]	12.25 [311]
	Flange bolts, amount; in [mm]	8; 1¼ [32]
Weight, lbm [kg]	Weld, and threaded end	162 [73]
	Flanged end	320 [145]
B, height, center to top (open), in [mm]		21.25 [540]
C, handle diameter, in [mm]		23.00 [854]



Assembly Part Number Example

**J003948-6 7 2 2 1 2 2**

Assembly Base Number  
4 in [100 mm]

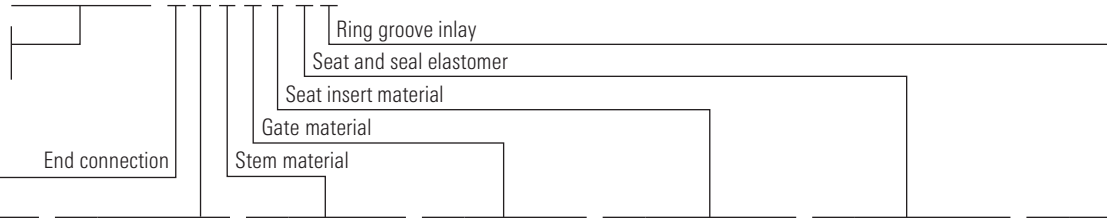

End Connection		Body Configuration		Stem Material		Gate Material		Seat Insert Material		Seat and Seal Elastomer		Ring Groove Inlay	
No.	Description	No.	Description	No.	Description	No.	Description	No.	Description	No.	Description	No.	Description
<b>Flanged</b>													
6	1500 RTJ	4	Threaded	2	303 SS	2	41XX	1	1045	1		Buna-N and Buna-N	
7	1500 RF	5	Weld	8	316 SS	8	ASTM A351 Gr. CF8M	8	ASTM A351 Gr. CF8M	2		FKM and FKM	
<b>Weld</b>													
0	Sch. 40												
1	Sch. 80												
5	Sch. 160												
<b>Threaded</b>													
0	LP												
3	LCSG												

<sup>†</sup> Inlay only available on flanged valves.

Parts List

Key No.	Qty.	Description	Valve Seat Port Size for ASME 1500 Class: 4 in [100 mm]
<b>Assembly Base Number—General Service</b>			<b>J003010</b>
1	1	Body	ASTM A487 Gr. 4 Class A
2	1	Bonnet	ASTM A487 Gr. 4 Class A
3 <sup>†</sup>	1	Gate	41XX with ENP ASTM A351 Gr. CF8M
4	1	Handle	ASTM A536 Gr. 65-45-12
5	4	Heavy hex nut, body	ASTM A194 Gr. 2H
6	2	Heavy hex nut, bonnet	ASTM A194 Gr. 2H
7	1	Housing	CD 1029
8	1	Lock handle	CD 1213/15
9	1	Lubricating nipple, 1/8 NPT	Steel
10 <sup>†</sup>	1	O-ring, bonnet seal	Buna-N FKM
11 <sup>†</sup>	1	O-ring, housing seal	Buna-N
12 <sup>†</sup>	1	O-ring, secondary seal	Buna-N
13	1	Retainer	CD 1213/15
14 <sup>†</sup>	1	Seat assembly	1045 and Buna-N 1045 and FKM ASTM A351 Gr. CF8M and Buna-N ASTM A351 Gr. CF8M and FKM
15	1	Split pin, 3/16 in × 1 3/4 in	Steel
16 <sup>†</sup>	1	Stem	303 SS 316 SS
17 <sup>†</sup>	1	Stem screw	CD 1213/15
18 <sup>†</sup>	1	Stem seal assembly with bushing	Buna-N and bronze FKM and bronze
19	2	Stud (continuous), bonnet	ASTM A193 Gr. B7
20	4	Stud (double ended), body	ASTM A193 Gr. B7

<sup>†</sup> Recommended spare parts. Contact Cameron for specific part numbers.

# Series DMA gate valves — 7,500-psi WP — Automated

2-in [50-mm] seat port

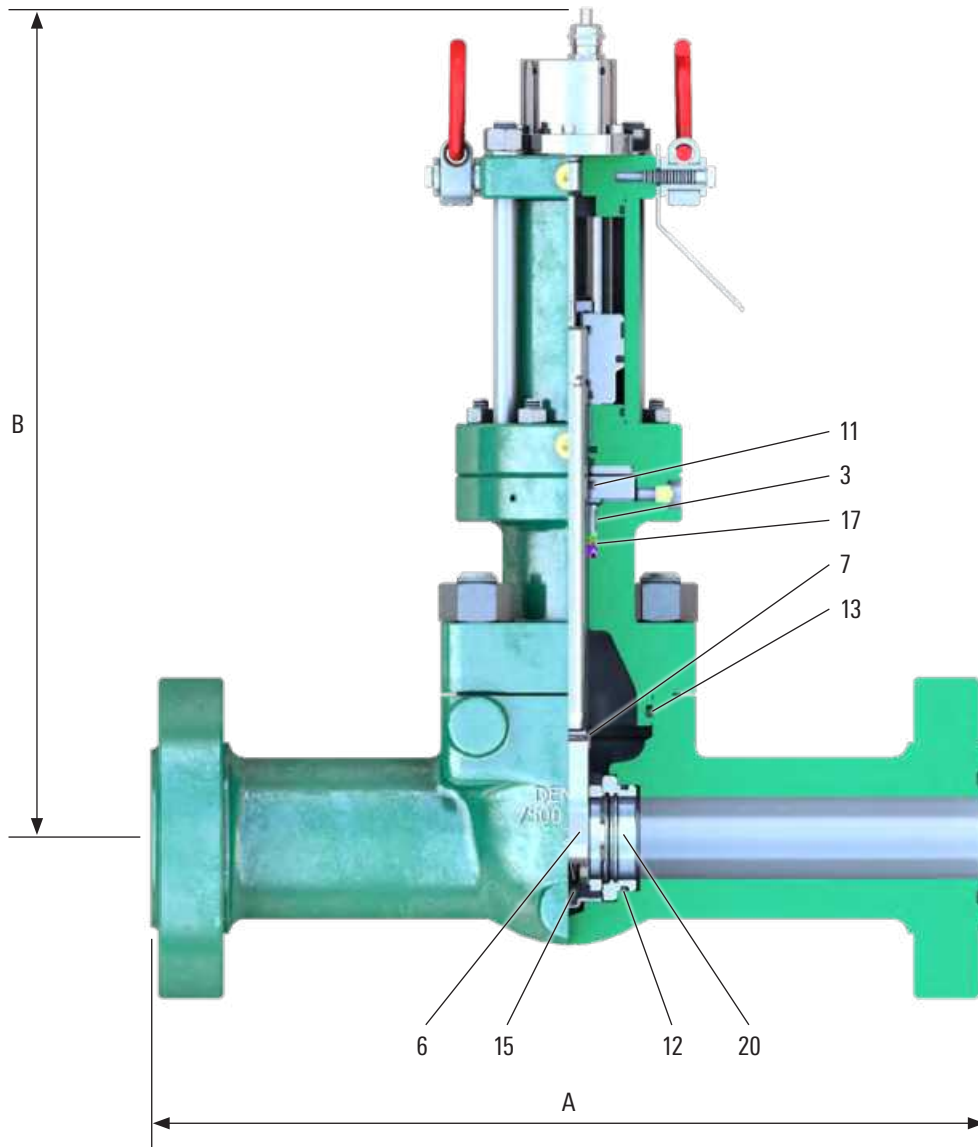

## Dimensional Data and Weights

Dimension	Valve Seat Port Size for for 7,500-psi WP: 2 in [50 mm]	
A, length, in [mm]	Weld end	9.00 [229]
	Flanged end	20.50 [521]
	Hammer union end	15.74 [400]
For flanged ends	API ring number	BX-152
	Flange ID, in [mm]	2.00 [50]
	Flange OD, in [mm]	7.88 [200]
	Flange bolts, amount; in [mm]	8; ¾ [19]
Weight, with actuator, lbm [kg]	Weld end	108 [49]
	Flanged end	169 [77]
	Hammer union end	126 [57]
Cylinder max pressure, psi [MPa]	3,000 [20.7]	
Cylinder inlet/outlet connection	4X ¾ NPT	
B, height, center to top, in [mm]	19.95 [507]	



Assembly Part Number Example

**J025296-3 7 8 9 1 2 0 1**

Assembly Base Number  
2 in [50 mm]

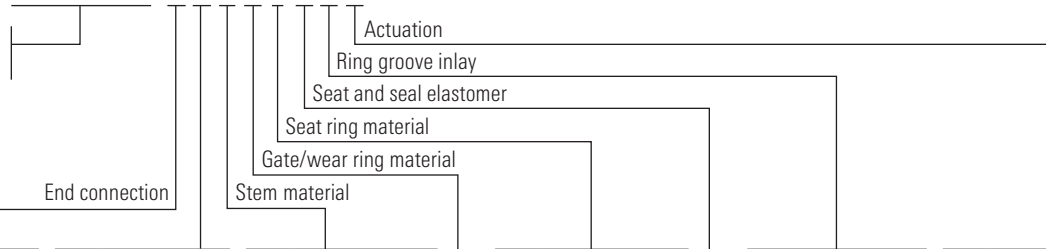

End Connection		Body Configuration		Stem Material		Seat Ring Material		Ring Groove Inlay		Actuation	
No.	Description	No.	Description	No.	Description	No.	Description	No.	Description	No.	Description
<b>Flanged</b>											
3	10000 RTJ	5	Weld	8	17-4 PH SS	1	410 SS	0	—	1	With hydraulic Ledeen* actuator
<b>Weld</b>											
2	2.00 in [50 mm] XXH	7	Flanged	<b>Gate/Wear Ring Material</b>		<b>Seat and Seal Elastomer</b>		1	316 SS Inlay <sup>†</sup>	2	Bare stem for actuation
4	3.00 in [80 mm] OD × 2.00 in [50mm] ID	9	Hammer union	<b>No. Description</b>		<b>No. Description</b>		2	625 SS Inlay <sup>†</sup>		
<b>Hammer Union</b>											
8	2.00 in [50 mm] XXH 1502 hammer union			8 17-4 PH SS/410 SS		2 FKM		<sup>†</sup> Inlay only available on flanged valves.			
				9 17-4 PH SS/41XX		4 HNBR					

Parts List

Repair Kit	Key No.	Qty.	Description	Valve Seat Port Size for 7,500-psi WP: 3 in [80 mm]			Repair Kit Component Part Numbers
				Group 1	Group 2	Group 3	
<b>Assembly Base Number — NACE Compliant</b>				<b>J025296</b>	<b>J025343</b>	<b>J025344</b>	
	1	1	Body	ASTM A487 Gr. 4 Class D			—
	2	1	Bonnet	4130			—
■	3	1	Bushing	Gar-Fil composite			—
	4	1	Breather vent, 1/8 NPT	Steel			X-213635-01
	5	4	Capscrew socket head, 3/8 UNC × 0.75 (long)	ASTM A320 Gr. L7M			—
■	6	1	Gate	17-4 PH SS with QPQ nitriding			2603688-01
■	7	1	Gate clip	3XX SS			M450480
	8	12	Heavy hex nut, 1-8 UNC	ASTM A194 Gr. 2H	ASTM A194 Gr. 7		—
	9	8	Heavy hex nut, 3/8-16 UNC	ASTM A194 Gr. 7			—
	10	1	Ledeen actuator model LHL 70-60 DA	Assembly			—
■	11	1	O-ring, AS-568-224, rod wiper	Buna-N			J005526-214
■	12	2	O-ring, AS-568-229, wear ring seal	HNBR			2712425-03
				FKM			J005521-229
■	13	1	O-ring, AS-568-342, bonnet seal	HNBR			2712425-60
				FKM			J005521-342
	14	1	Retainer	41XX			—
■	15	1	Seat assembly	410 SS with QPQ nitriding and HNBR			2139742-01
				410 SS with QPQ nitriding and FKM			2139741-02
	16	1	Stem	17-4 PH SS with ENP			—
■	17	1	Stem seal assembly	HNBR			X-213640-01
				FKM			X-213640-02
	18	12	Stud (double ended), 1-8 UNC × 4.00 (long)	ASTM A193 Gr. B7	ASTM A193 Gr. L7		—
	19	8	Stud (double ended), 3/8-16 UNC × 2.25 (long)	ASTM A320 Gr. L7			—
■	20	2	Wear ring	41XX with QPQ nitriding			M452267
				410 SS			2139647-02

■ Major repair kit J025177-10279—one each for one year of service.  
Major repair kits listed for trim option J0XXXXX-XX891401 (17-4 PH SS stem, 17-4 PH SS with QPQ gate, HNBR seat and seals). Consult Cameron for other repair kit trim options.

# Series DMA gate valves — 7,500-psi WP — Automated

**3-in [80-mm] seat port**

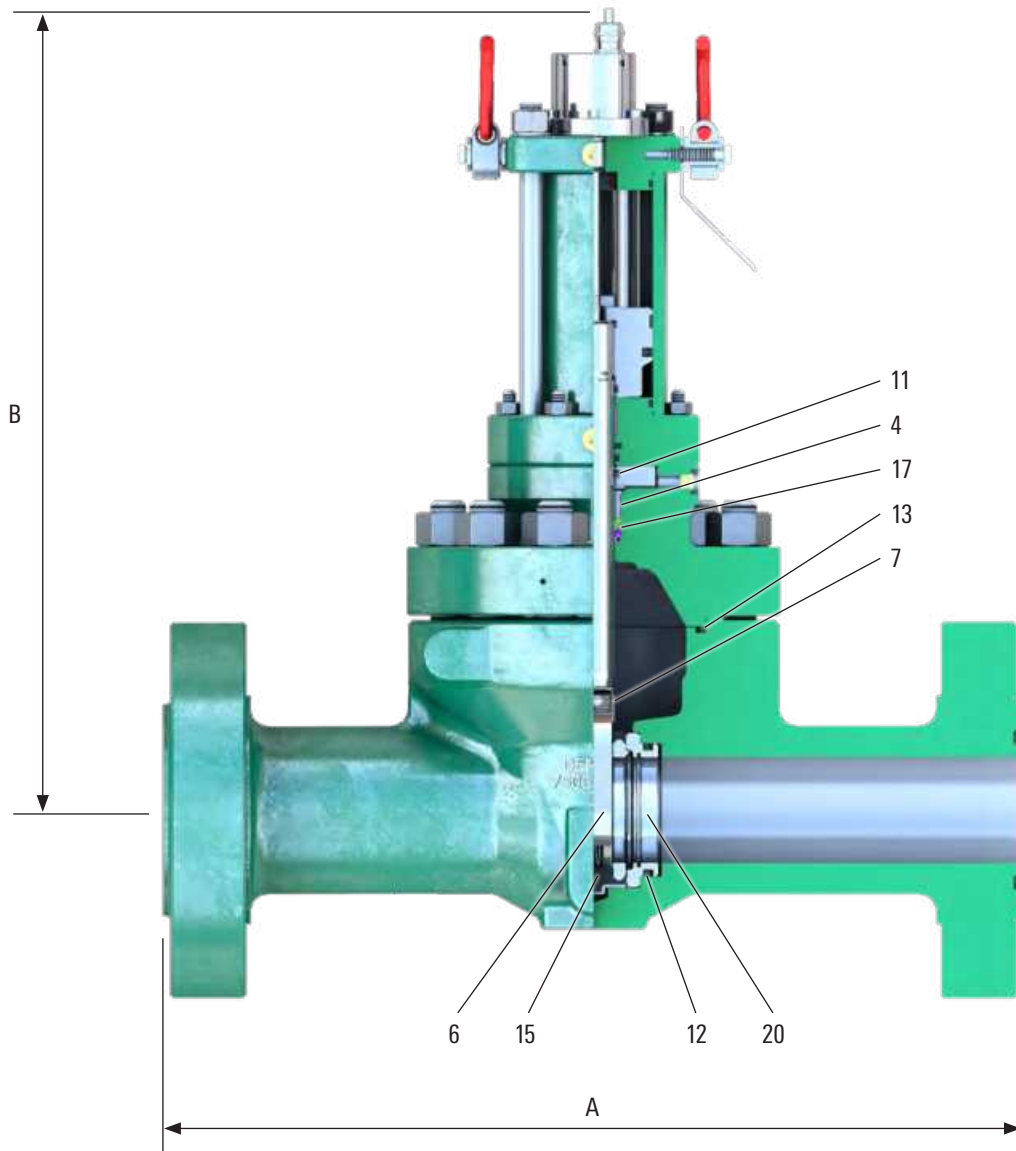

## Dimensional Data and Weights

Dimension	Valve Seat Port Size for for 7,500-psi WP: 3 in [80 mm]		
A, length, in [mm]	Weld end	13.00 [330]	
	Flanged end	24.38 [619]	
	Hammer union end	4 in	24.62 [625]
		3 in	18.88 [480]
For flanged ends	API ring number	BX-154	
	Flange ID, in [mm]	3.00 [80]	
	Flange OD, in [mm]	10.62 [270]	
	Flange bolts, amount; in [mm]	8; 1 [25]	
Weight, with actuator, lbm [kg]	Weld end	215 [97]	
	Flanged end	328 [149]	
	Hammer union end	4 in	299 [135]
		3 in	241 [109]
Cylinder max pressure, psi [MPa]	3,000 [20.7]		
Cylinder inlet/outlet connection	4X 3/8 NPT		
B, height, center to top, in [mm]	22.26 [565]		



Assembly Part Number Example

**J025295-3 7 8 8 1 4 2 1**

Assembly Base Number

3 in [80 mm]

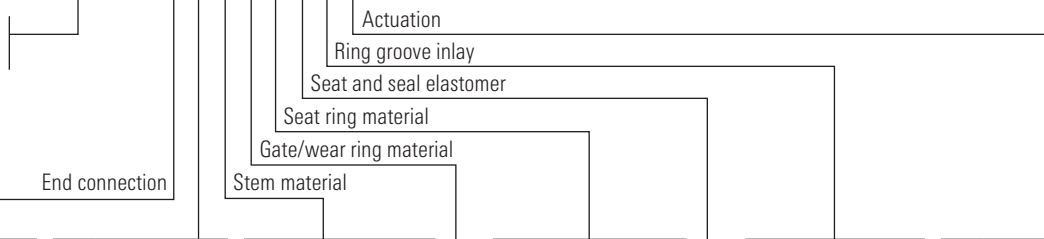

End Connection		Body Configuration		Stem Material		Seat Ring Material		Ring Groove Inlay		Actuation	
No.	Description	No.	Description	No.	Description	No.	Description	No.	Description	No.	Description
<b>Flanged</b>											
3	10000 RTJ	5	Weld	8	17-4 PH SS	1	410 SS	0	—	1	With hydraulic Ledeen actuator
<b>Weld</b>											
2	3.00 in [80 mm] XXH	7	Flanged	<b>Gate/Wear Ring Material</b>		<b>Seat and Seal Elastomer</b>		1	316 SS Inlay <sup>†</sup>	2	Bare stem for actuation
4	4.00 in [100 mm] XXH	9	Hammer union	<b>No. Description</b>		<b>No. Description</b>		2	625 SS Inlay <sup>†</sup>		
5	4.50 in [114 mm] OD × 2.96 in [75 mm] ID			8	17-4 PH SS/410 SS	2	FKM	<sup>†</sup> Inlay only available on flanged valves.			
<b>Hammer Union</b>											
8	3.00 in [80 mm] XXH 1502 hammer union			9	17-4 PH SS/41XX	4	HNBR				
9	4.00 in [100 mm] XXH 1502 hammer union										

Parts List

Repair Kit	Key No.	Qty.	Description	Valve Seat Port Size for 7,500-psi WP: 2 in [50 mm]			Repair Kit Component Part Numbers
				Group 1	Group 2	Group 3	
<b>Assembly Base Number — NACE Compliant</b>				<b>J025295</b>	<b>J025331</b>	<b>J025332</b>	
	1	1	Body	ASTM A487 Gr. 4 Class D			—
	2	1	Bonnet	4130			—
	3	1	Breather vent, 1/8 NPT	Steel			—
■	4	1	Bushing	Gar-Fil composite			X-213633-01
	5	4	Capscrew socket head, 3/8 UNC × 0.75 (long)	ASTM A320 Gr. L7M			—
■	6	1	Gate	17-4 PH SS with QPQ nitriding			X-213643-01
■	7	1	Gate clip	3XX SS			X-213652-01
	8	12	Heavy hex nut, 1-8 UNC	ASTM A194 Gr. 2H	ASTM A194 Gr. 7		—
	9	8	Heavy hex nut, 3/8-16 UNC	ASTM A194 Gr. 7			—
	10	1	Ledeen actuator model LHL 85-84 DA	Assembly			—
■	11	1	O-ring, AS-568-217, rod wiper	Buna-N			J005526-217
■	12	2	O-ring, AS-568-340, wear ring seal	HNBR			2712783-03
				FKM			J005521-340
■	13	1	O-ring, AS-568-361, bonnet seal	HNBR			2712787-07
				FKM			J005521-361
	14	1	Retainer	41XX			—
■	15	1	Seat assembly	410 SS with QPQ nitriding and HNBR			2139744-01
				410 SS with QPQ nitriding and FKM			2139743-02
	16	1	Stem	17-4 PH SS			—
■	17	1	Stem seal assembly	HNBR			X-213638-01
				FKM			X-213638-02
	18	12	Stud (double ended), 1-8 UNC × 4.50 (long)	ASTM A193 Gr. B7	ASTM A320 Gr. L7		—
	19	8	Stud (double ended), 3/8-16 UNC × 2.25 (long)	ASTM A320 Gr. L7			—
■	20	2	Wear ring	41XX with QPQ nitriding			M452571
				410 SS			2139648-02

■ Major repair kit J025177-10379—one each for one year of service.  
 Major repair kits listed for trim option J0XXXXX-XX891401 (17-4 PH SS stem, 17-4 PH SS with QPQ gate, HNBR seat and seals).  
 Consult Cameron for other repair kit trim options.

# Series DMA gate valves — 7,500-psi WP — Automated

4-in [100-mm] seat port

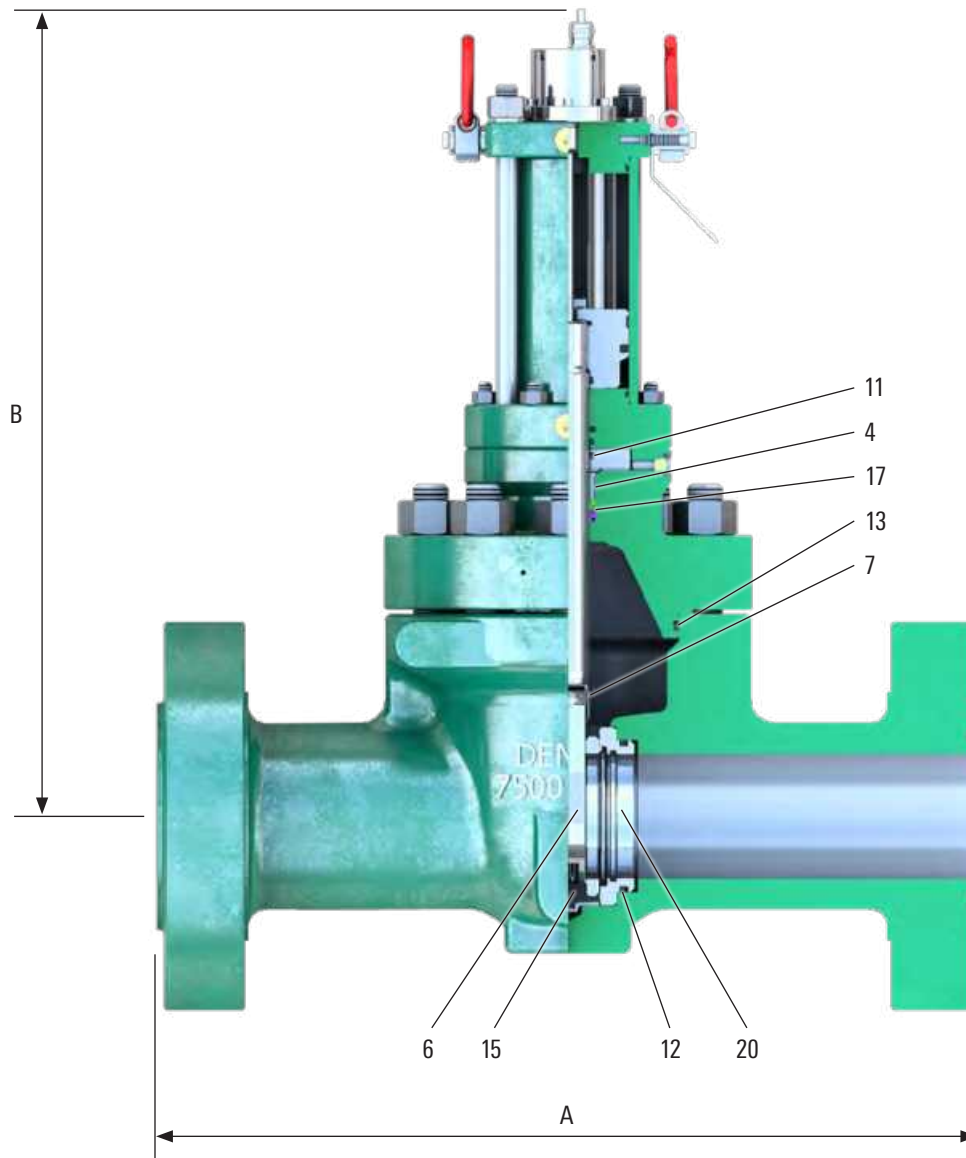

## Dimensional Data and Weights

Dimension	Valve Seat Port Size for for 7,500-psi WP: 4 in [100 mm]		
A, length, in [mm]	Weld end	16.00 [406]	
	Flanged end	26.38 [670]	
	Hammer union end	5 in	25.62 [651]
		4 in	27.62 [702]
For flanged ends	API ring number	BX-155	
	Flange ID, in [mm]	4.00 [100]	
	Flange OD, in [mm]	12.44 [316]	
	Flange bolts, amount; in [mm]	8; 1½ [29]	
Weight, with actuator, lbm [kg]	Weld end	311 [140]	
	Flanged end	486 [220]	
	Hammer union end	5 in	409 [185]
		4 in	395 [179]
Cylinder max pressure, psi [MPa]	3,000 [20.7]		
Cylinder inlet/outlet connection	4X ½ NPT		
B, height, center to top, in [mm]	25.47 [647]		



Assembly Part Number Example

**J025294-3 7 8 8 1 2 1 2**

Assembly Base Number  
4 in [100 mm]

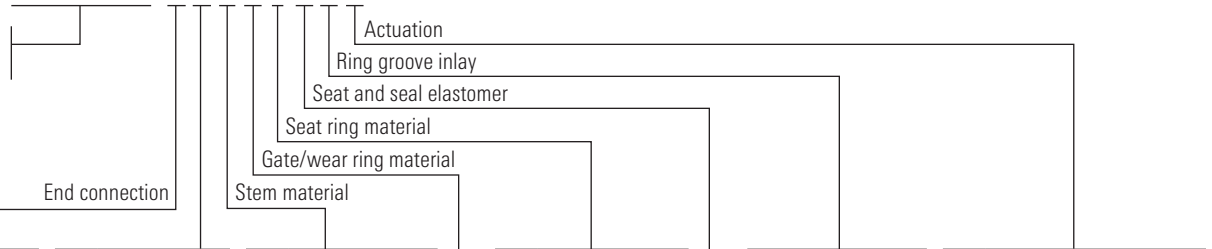

End Connection		Body Configuration		Stem Material		Seat Ring Material		Ring Groove Inlay		Actuation	
No.	Description	No.	Description	No.	Description	No.	Description	No.	Description	No.	Description
<b>Flanged</b>		5	Weld	8	17-4 PH SS	1	410 SS	0	—	1	With hydraulic Ledeen actuator
3	10000 RTJ	7	Flanged					1	316 SS Inlay <sup>†</sup>	2	Bare stem for actuation
<b>Weld</b>		9	Hammer Union	<b>Gate/Wear Ring Material</b>		<b>Seat and Seal Elastomer</b>		2	625 SS Inlay <sup>†</sup>		
2	4.00 in [100 mm] XXH			<b>No. Description</b>		<b>No. Description</b>					
3	5.00 in [125 mm] XXH			8	17-4 PH SS/410 SS	2	FKM				
4	5.81 in [148 mm] OD × 4.06 in [103 mm]			9	17-4 PH SS/41XX	4	HNBR				
5	6.00 in [152 mm] OD × 4.00 in [100 mm] ID										
<b>Threaded</b>											
8	4.00 in [100 mm] XXH 1502 Hammer Union										
9	5.00 in [125 mm] XXH 1502 Hammer Union										

<sup>†</sup> Inlay only available on flanged valves.

Parts List

Repair Kit	Key No.	Qty.	Description	Valve Seat Port Size for 7,500-psi WP: 4 in [100 mm]			Repair Kit Component Part Numbers
				Group 1	Group 2	Group 3	
			<b>Assembly Base Number — NACE Compliant</b>	<b>J025294</b>	<b>J025329</b>	<b>J025330</b>	
	1	1	Body	ASTM A487 Gr. 4 Class D			—
	2	1	Bonnet	4130			—
	3	1	Breather vent, 1/8 NPT	Steel			—
■	4	1	Bushing	Gar-Fil composite			X-213632-01
	5	4	Capscrew socket head, 7/16 UNC × 0.88 (long)	ASTM A320 Gr. L7M			—
■	6	1	Gate	17-4 PH SS with QPQ nitriding			X-213642-01
■	7	1	Gate clip	3XX SS			X-213651-01
	8	10	Heavy hex nut, 1 1/8-8 UNC	ASTM A194 Gr. 2H	ASTM A194 Gr. 7		—
	9	8	Heavy hex nut, 7/16-14 UNC	ASTM A194 Gr. 7			—
	10	1	Ledeen actuator model LHL 100-110 DA	Assembly			—
■	11	1	O-ring, AS-568-220, rod wiper	Buna-N			J005526-220
■	12	2	O-ring, AS-568-349, wear ring seal	HNBR			2712787-04
				FKM			J005521-349
■	13	1	O-ring, AS-568-364, bonnet seal	HNBR			2712426-11
				FKM			J005521-364
	14	1	Retainer	41XX			—
■	15	1	Seat assembly	410 SS with QPQ nitriding and HNBR			2139746-01
				410 SS with QPQ nitriding and FKM			2139745-02
	16	1	Stem	17-4 PH SS			—
■	17	1	Stem seal assembly	HNBR			X-213637-01
				FKM			X-213637-02
	18	10	Stud (double ended), 1 1/8-8 UNC × 5.50 (long)	ASTM A193 Gr. B7	ASTM A320 Gr. L7		—
	19	8	Stud (double ended), 7/16-14 UNC × 2.63 (long)	ASTM A320 Gr. L7			—
■	20	2	Wear ring	41XX with QPQ nitriding			M452290
				410 SS			2139649-02

■ Major repair kit J025177-10479 — one each for one year of service.  
Major repair kits listed for trim option J0XXXXX-XX891401 (17-4 PH SS stem, 17-4 PH with QPQ gate, HNBR seat and seals).  
Consult Cameron for other repair kit trim options.

# Series DMA gate valves — 7,500-psi WP — Automated

## 5.12-in [130-mm] seat port

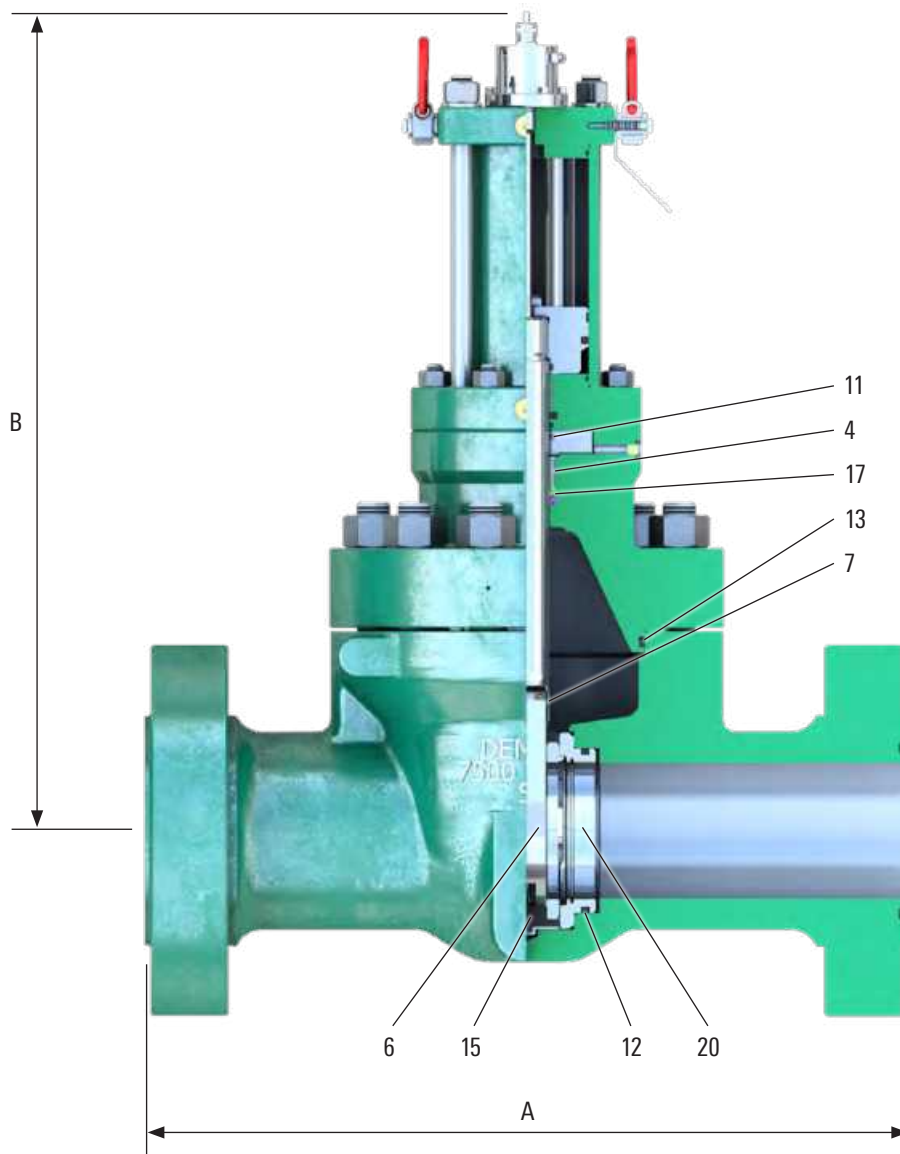

### Dimensional Data and Weights

Dimension	Valve Seat Port Size for for 7,500-psi WP: 5.12 in [130 mm]	
A, length, in [mm]	Weld end	17.88 [454]
	Flanged end	29.00 [737]
For flanged ends	API ring number	BX-169
	Flange ID, in [mm]	5.12 [130]
	Flange OD, in [mm]	14.06 [357]
	Flange bolts, amount; in [mm]	12; 1½ [29]
Weight, with actuator, lbm [kg]	Weld end	600 [272]
	Flanged end	839 [381]
Cylinder max pressure, psi [MPa]	3,000 [20.7]	
Cylinder inlet/outlet connection	4X ½ NPT	
B, height, center to top, in [mm]	30.66 [779]	





# Series DMA gate valves — 5,000-psi WP — Automated

2-in [50-mm] seat port

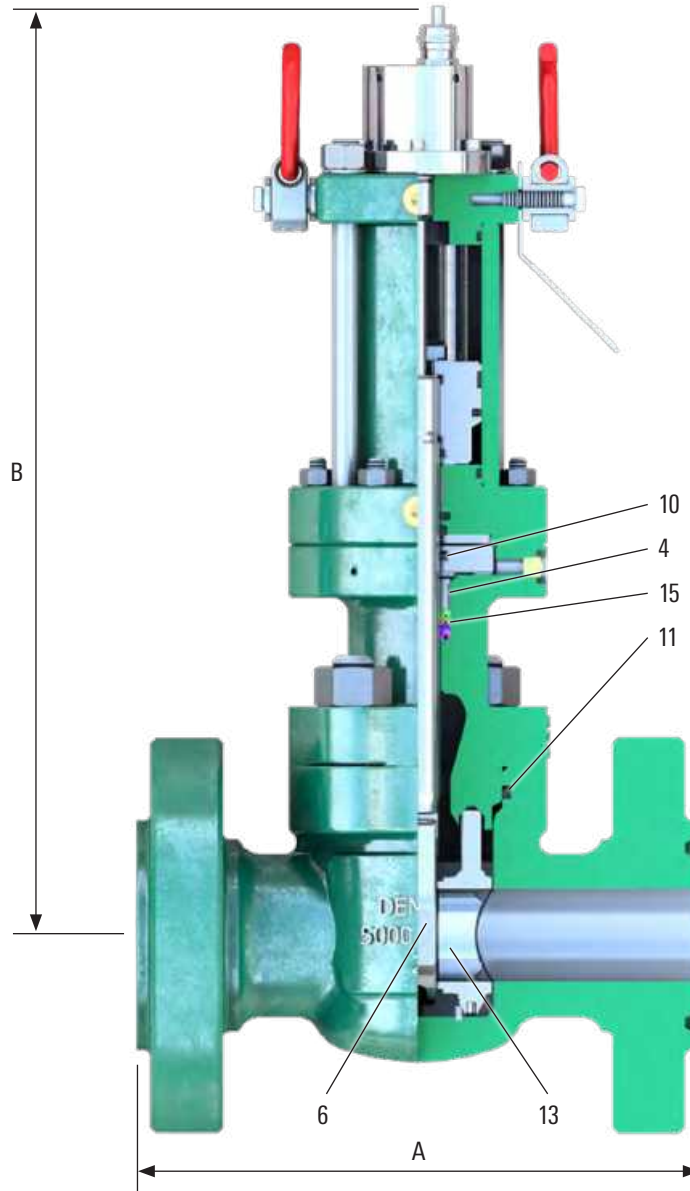

## Dimensional Data and Weights

Dimension	Valve Seat Port Size for for 5,000-psi WP: 2 in [50 mm]	
A, length, in [mm]	Weld end	9.00 [229]
	Flanged end	12.12 [308]
	Hammer union end	15.74 [400]
For flanged ends	API ring number	R-24
	Flange ID, in [mm]	2.00 [50]
	Flange OD, in [mm]	8.50 [216]
	Flange bolts, amount; in [mm]	8; 7/8 [22]
Weight, with actuator, lbm [kg]	Weld, and threaded end	86 [39]
	Flanged end	131 [60]
	Hammer union end	105 [48]
Cylinder max pressure, psi [MPa]	3,000 [20.7]	
Cylinder inlet/outlet connection	4X 3/8 NPT	
B, height, center to top, in [mm]	19.56 [497]	



Assembly Part Number Example

**J025341-27991212**

Assembly Base Number  
2 in [50 mm]

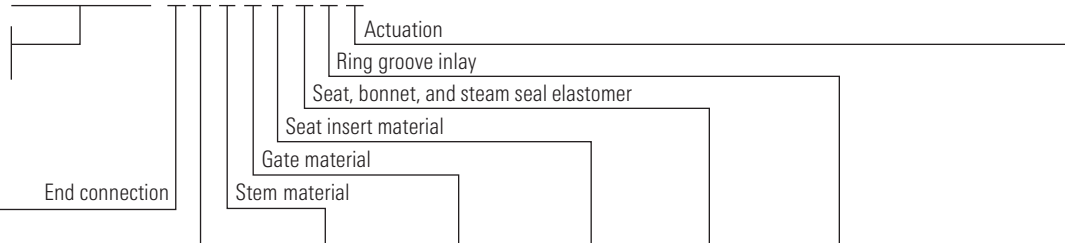

End Connection	
No.	Description
<b>Flanged</b>	
2	5000 RTJ
<b>Weld</b>	
1	Sch. 80
2	XXH
5	Sch. 160
<b>Threaded</b>	
0	LP
2	UPTBG
<b>Hammer Union</b>	
9	2.00 in [50 mm] XXH 1502 Hammer Union

Body Configuration	
No.	Description
4	Threaded
5	Weld
7	Flanged
9	Hammer Union

Stem Material	
No.	Description
9	17-4 PH SS

Gate Material	
No.	Description
9	17-4 PH SS

Seat Insert Material	
No.	Description
1	1045
8	ASTM A351 Gr CF8M

Seat, Bonnet, and Steam Seal Elastomer	
No.	Description
1	Buna-N/HNBR
2	FKM/FKM

Ring Groove Inlay	
No.	Description
0	—
1	316 SS Inlay <sup>†</sup>
2	625 SS Inlay <sup>†</sup>

Actuation	
No.	Description
1	With hydraulic Ledeen actuator
2	Bare stem for actuation

<sup>†</sup> Inlay only available on flanged valves.

Parts List

Repair Kit	Key No.	Qty.	Description	Valve Seat Port Size for 5,000-psi WP: 2 in [50 mm]	Repair Kit Component Part Numbers
			<b>Assembly Base Number — NACE Compliant</b>		
			<b>2-in [50-mm] nominal end—threaded, flanged, weld, and hammer</b>	<b>J025341</b>	
			<b>2.5-in [65-mm] nominal end—weld</b>	<b>J025342</b>	
	1	1	Body	ASTM A487 Gr. 4 Class D	—
	2	1	Bonnet	ASTM A487 Gr. 4 Class D	—
	3	1	Breather vent, 1/8 NPT	Steel	—
■	4	1	Bushing	Gar-Fil composite	X-213635-01
	5	4	Capscrew socket head, 3/8 UNC x 0.75 (long)	ASTM A320 Gr. 7	—
■	6	1	Gate	17-4 PH SS with QPQ nitriding	2603181-01
	7	4	Heavy hex nut, 7/8-9 UNC	ASTM A194 Gr. 2H	—
	8	8	Heavy hex nut, 3/8-16 UNC	ASTM A194 Gr. 7ML	—
	9	1	Ledeen actuator model LHL 70-63 DA	Assembly	—
■	10	1	O-ring, AS-568-214, rod wiper	Buna-N	J005526-214
■	11	1	O-ring, AS-568-439, bonnet seal	Buna-N	J005526-342
				FKM	J005531-342
	12	1	Retainer	41XX	—
■	13	1	Seat assembly	1045 and Buna-N	J001876-011
				1045 and FKM	J001876-012
				ASTM A351 Gr. CF8M and Buna-N	J001876-081
				ASTM A351 Gr. CF8M and FKM	J001876-082
	14	1	Stem	17-4 PH SS	—
■	15	1	Stem seal assembly	HNBR	X-213640-01
				FKM	X-213640-02
	16	4	Stud (double ended), 3/8-16 UNC x 2.25 (long)	ASTM A320 Gr. L7M	—
	17	8	Stud (double ended), 7/8-9 UNC x 3.25 (long)	ASTM A193 Gr. B7	—

■ Major repair kit J025216-14229 — one each for one year of service.

Major repair kits listed for trim option J0XXXXX-XX991101 (17-4 PH SS with QPQ nitriding, 1045 insert, Buna-N seat, bonnet seal, and HNBR steam seal).

Consult Cameron for other repair kit trim options.

# Series DMA gate valves — 5,000-psi WP — Automated

4-in [100-mm] seat port

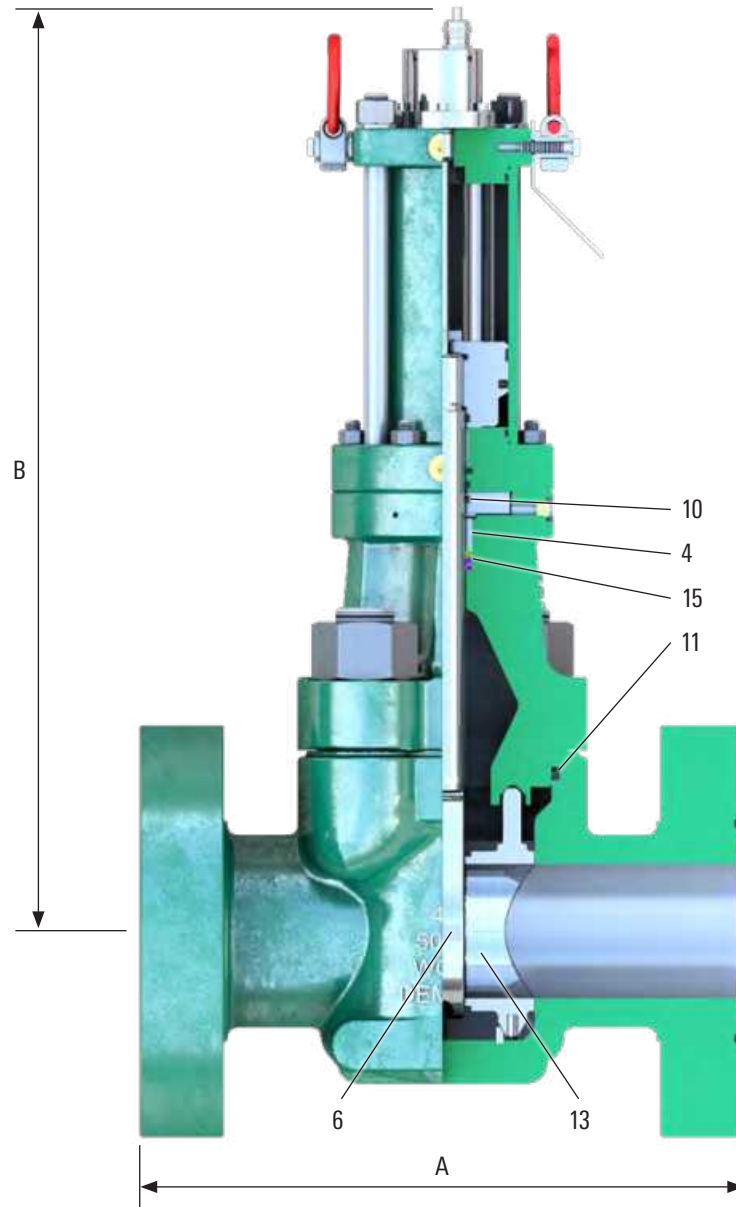

## Dimensional Data and Weights

Dimension	Valve Seat Port Size for for 5,000-psi WP: 4 in [100 mm]		
A, length, in [mm]	Weld end	13.00 [330]	
	Flanged end	18.00 [457]	
	Hammer union end	5 in	22.62 [574]
		4 in	24.62 [625]
For flanged ends	API ring number	R-39	
	Flange ID, in [mm]	4.00 [100]	
	Flange OD, in [mm]	12.25 [311]	
	Flange bolts, amount; in [mm]	8; 1¼ [32]	
Weight, with actuator, lbm [kg]	Weld, and threaded end	272 [123]	
	Flanged end	409 [185]	
	Hammer union end	5 in	368 [167]
		4 in	364 [165]
Cylinder max pressure, psi [MPa]	3,000 [20.7]		
Cylinder inlet/outlet connection	4X ½ NPT		
B, height, center to top, in [mm]	27.11 [689]		

Assembly Part Number Example

**J025297-27998101**

Assembly Base Number  
4 in [100 mm]

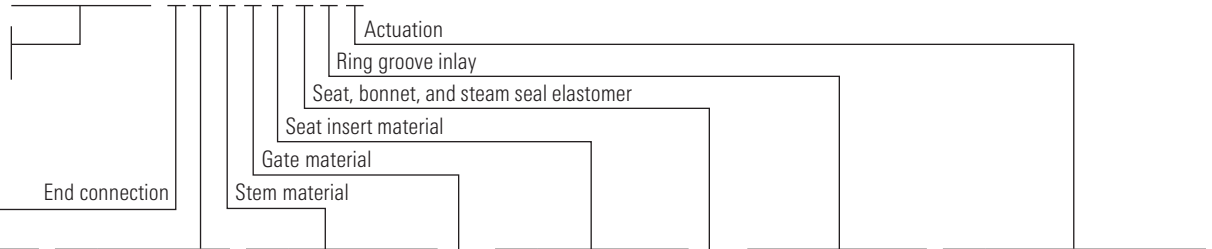

End Connection		Body Configuration		Stem Material		Seat Insert Material		Ring Groove Inlay		Actuation	
No.	Description	No.	Description	No.	Description	No.	Description	No.	Description	No.	Description
<b>Flanged</b>											
2	5000 RTJ	4	Threaded	9	17-4 PH SS	1	1045	0	—	1	With hydraulic Ledeen actuator
<b>Weld</b>											
1	Sch. 80	5	Weld			8	ASTM A351 Gr CF8M	1	316 SS Inlay <sup>†</sup>	2	Bare stem for actuation
2	XXH	7	Flanged					2	625 SS Inlay <sup>†</sup>		
5	Sch. 160	9	Hammer Union								
<b>Threaded</b>											
0	LP										
1	TBS										
<b>Hammer Union</b>											
8	4.00 in [100 mm] XXH 1502 Hammer Union										
9	5.00 in [125 mm] XXH 1502 Hammer Union										

<sup>†</sup> Inlay only available on flanged valves.

Parts List

Repair Kit	Key No.	Qty.	Description	Valve Seat Port Size for 5,000-psi WP: 4 in [100 mm]		Repair Kit Component Part Numbers
				Assembly Base Number — NACE Compliant		
			4-in [100-mm] nominal end—threaded, flanged, weld, and hammer	J025297		
			5-in [125-mm] nominal end—weld and hammer	J025333		
	1	1	Body	ASTM A487 Gr. 4 Class D		—
	2	1	Bonnet	ASTM A487 Gr. 4 Class D		—
	3	1	Breather vent, 1/8 NPT	Steel		—
■	4	1	Bushing	Gar-Fil composite		X-213632-01
	5	4	Capscrew socket head, 7/16 UNC × 0.88 (long)	ASTM A320 Gr. 7		—
■	6	1	Gate	17-4 PH SS with QPQ nitriding		2603247-01
	7	4	Heavy hex nut, 1 1/4 special	ASTM A194 Gr. 2H		—
	8	8	Heavy hex nut, 7/16-14 UNC	ASTM A194 Gr. 7ML		—
	9	1	Ledeen actuator model LHL 100-119 DA	Assembly		—
■	10	1	O-ring, AS-568-220, rod wiper	Buna-N		J005526-220
■	11	1	O-ring, AS-568-439, bonnet seal	Buna-N		J005526-439
				FKM		J005531-439
	12	1	Retainer	41XX		—
■	13	1	Seat assembly	1045 and Buna-N		X-213637-01
				1045 and FKM		X-213637-02
				ASTM A351 Gr. CF8M and Buna-N		J002207-081
				ASTM A351 Gr. CF8M and FKM		J002207-082
	14	1	Stem	17-4 PH SS		—
■	15	1	Stem seal assembly	HNBR		X-213637-01
				FKM		X-213637-02
	16	4	Stud (double ended), 1 1/4 special × 6.00 (long)	ASTM A193 Gr. B7		—
	17	8	Stud (double ended), 7/16-14 UNC × 2.63 (long)	ASTM A320 Gr. L7		—

■ Major repair kit J025216-14229—one each for one year of service.

Major repair kits listed for trim option J0XXXXX-XX991101 (17-4 PH SS with QPQ nitriding, 1045 insert, Buna-N seat, bonnet seal, and HNBR steam seal).

Consult Cameron for other repair kit trim options.

# Series DMA gate valves — 5,000-psi WP — Automated

## 5.12-in [130-mm] seat port

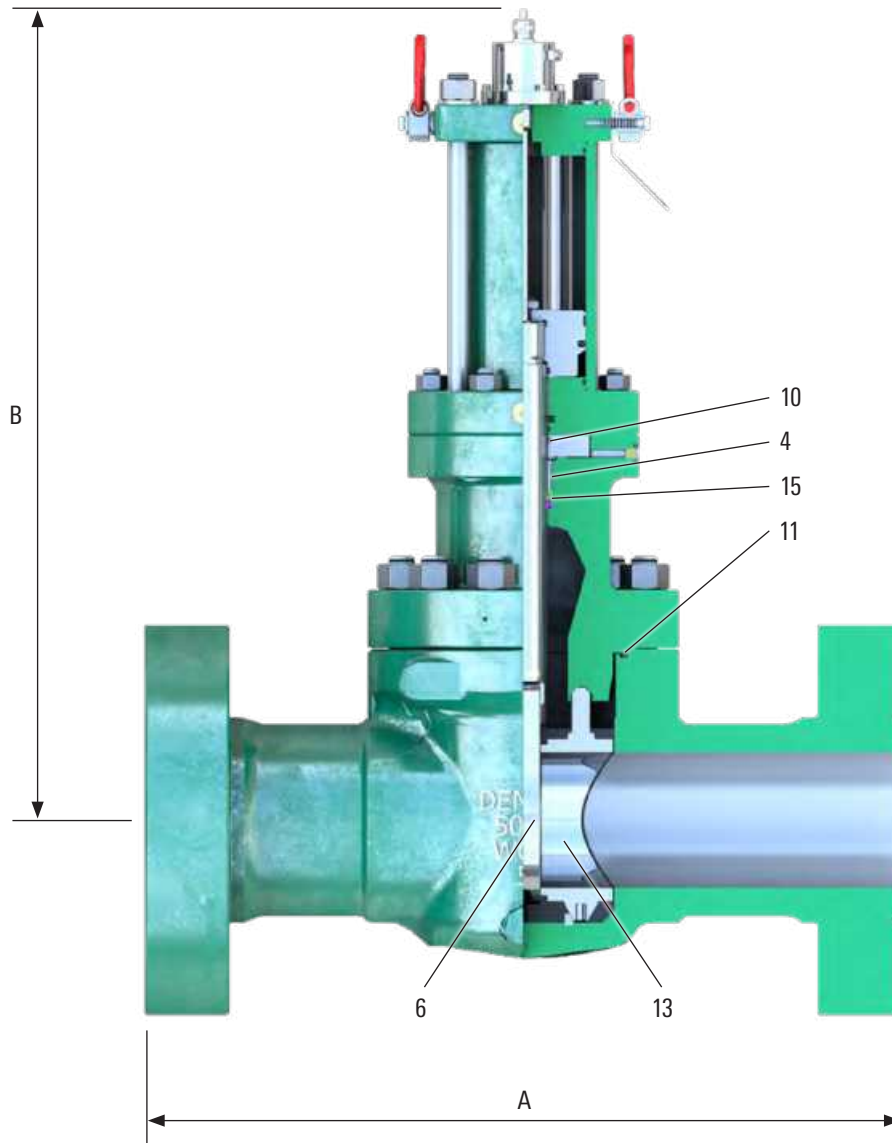

### Dimensional Data and Weights

Dimension	Valve Seat Port Size for for 5,000-psi WP: 5.12 in [130 mm]	
A, length, in [mm]	Weld end	16.00 [406]
	Flanged end	28.62 [727]
For flanged ends	API ring number	R-44
	Flange ID, in [mm]	5.12 [130]
	Flange OD, in [mm]	14.75 [375]
	Flange bolts, amount; in [mm]	8; 1½ [38]
Weight, with actuator, lbm [kg]	Weld, and threaded end	415 [188]
	Flanged end	697 [316]
Cylinder max pressure, psi [MPa]	3,000 [20.7]	
Cylinder inlet/outlet connection	4X ½ NPT	
B, height, center to top, in [mm]	30.25 [768]	



Assembly Part Number Example

**J025325-77992211**

Assembly Base Number  
5.12 in [130 mm]

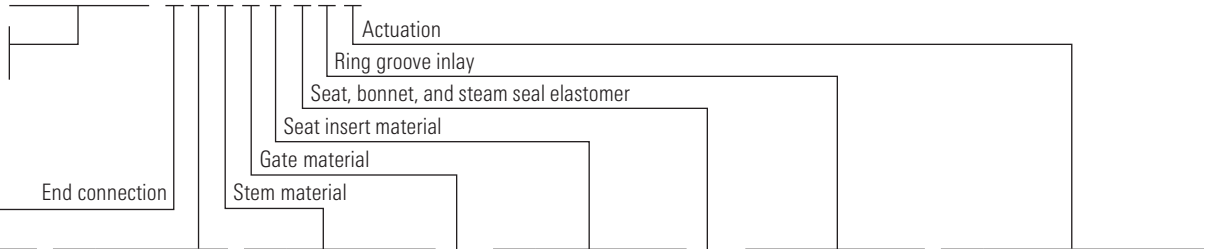

End Connection		Body Configuration		Stem Material		Seat Insert Material		Ring Groove Inlay		Actuation	
No.	Description	No.	Description	No.	Description	No.	Description	No.	Description	No.	Description
<b>Flanged</b>		4	Threaded	9	17-4 PH SS	1	1045	0	—	1	With hydraulic Ledeen actuator
7	5000 RTJ	5	Weld			8	ASTM A351 Gr CF8M	1	316 SS Inlay <sup>†</sup>	2	Bare stem for actuation
<b>Weld</b>		7	Flanged	<b>Gate Material</b>		<b>Seat, Bonnet, and Steam Seal Elastomer</b>		2	625 SS Inlay <sup>†</sup>		
2	XXH			<b>No. Description</b>		<b>No. Description</b>		<sup>†</sup> Inlay only available on flanged valves.			
5	Sch. 160			9	17-4 PH SS	1	Buna-N/HNBR				
<b>Threaded</b>						2	FKM/FKM				
3	LC										

Parts List

Repair Kit	Key No.	Qty.	Description	Valve Seat Port Size for 5,000-psi WP: 5.12 in [130 mm]	Repair Kit Component Part Numbers
			<b>Assembly Base Number — NACE Compliant</b>		
			<b>5-in [125-mm] nominal end—threaded and flanged</b>	<b>J025325</b>	
			<b>6-in [150-mm] nominal end—weld</b>	<b>J025334</b>	
		1	Body	ASTM A487 Gr. 4 Class D	—
		2	Bonnet	ASTM A487 Gr. 4 Class D	—
		3	Breather vent, 1/8 NPT	Steel	—
■		4	Bushing	Gar-Fil composite	X-213631-01
		5	Capscrew socket head, 5/8 UNC × 1.00 (long)	ASTM A320 Gr. L7M	—
■		6	Gate	17-4 PH SS with QPQ nitriding	2603248-01
		7	Heavy hex nut, 1-8 UNC	ASTM A194 Gr. 2H	—
		8	Heavy hex nut, 5/8-11 UNC	ASTM A194 Gr. 7ML	—
		9	Ledeen actuator model LHL 120-148 DA	Assembly	—
■		10	O-ring, AS-568-224, rod wiper	Buna-N	J005526-224
■		11	O-ring, AS-568-367, bonnet seal	Buna-N	J005520-367
				FKM	J005531-367
		12	Retainer	41XX	—
■		13	Seat assembly	1045 and Buna-N	J021948-019
				1045 and FKM	J021948-012
				ASTM A351 Gr. CF8M and Buna-N	J021948-099
				ASTM A351 Gr. CF8M and FKM	J021948-092
		14	Stem	17-4 PH SS	—
■		15	Stem seal assembly	HNBR	X-213636-01
				FKM	X-213636-02
		16	Stud (double ended), 1-8 UNC × 4.50 (long)	ASTM A193 Gr. B7	—
		17	Stud (double ended), 5/8-11 UNC × 3.25 (long)	ASTM A320 Gr. L7M	—

■ Major repair kit J025216-15229 — one each for one year of service.

Major repair kits listed for trim option J0XXXXX-XX991101 (17-4 PH SS with QPQ nitriding, 1045 insert, Buna-N seat, bonnet seal, and HNBR stem seal).

Consult Cameron for other repair kit trim options.

# Gate-Style DEMCO Valves



[products.slb.com/valves](https://products.slb.com/valves)

\*Mark of Schlumberger  
Other company, product, and service names  
are the properties of their respective owners.  
Copyright © 2019 Schlumberger. All rights reserved. 17-VL-362851

