

# AOP Series D Trunnion Mounted Ball Valve

TECHNOLOGY





## Table of Contents

<b>AOP SERIES D TRUNNION MOUNTED BALL VALVE</b>	
General Information.....	2
Features and Benefits.....	3
<b>ASME Class 150-900, 2" through 6" x 4"</b>	
Valve Assembly.....	4
Materials of Construction.....	5
Dimensions and Weights.....	6
Topworks Dimensions.....	8
<b>ASME Class 150-900, 6" through 12"</b>	
Valve Assembly.....	9
Materials of Construction.....	10
Dimensions and Weights.....	11
Topworks Dimensions.....	13
<b>ASME Class 1500, 2" x 2" through 6" x 4"</b>	
Valve Assembly.....	14
Materials of Construction.....	15
Dimensions and Weights.....	16
Topworks Dimensions.....	18
<b>ASME Class 2500 and 5000# MOP, 2" x 2" through 6" x 4"</b>	
Materials of Construction.....	19
Dimensions and Weights.....	20
<b>ASME Class 150-2500, 2" through 12"</b>	
Assembly Codes/Part Numbers.....	21
<b>API 5000, 2-1/16" through 4-1/16"</b>	
Assembly Codes/Part Numbers.....	22
Pressure Temperature Data.....	23
Specifications and Conformance.....	24
Flow Coefficients and Torque Values.....	25

## AOP Series D Trunnion Mounted Ball Valve

### GENERAL INFORMATION

Cameron's AOP™ brand offers a wide range of trunnion ball valves. The designs have been developed based on our customers' requirements.

When you specify an AOP ball valve, you have selected a premier product. With our state-of-the-art manufacturing techniques, our valves are manufactured to the highest standards ensuring superior performance.

All AOP ball valves are manufactured and tested in compliance with the requirements of API 6D specifications. These industry standards dictate end-to-end dimensions, flange configuration, port sizes, materials of construction, quality control procedures and testing requirements.

AOP ball valves are stocked by a network of authorized distributors to service the petroleum producing and refining industries in the US and Canada. AOP products are marketed worldwide by domestic and international representatives. Many of these representatives maintain local inventories for immediate delivery.

In addition to trunnion ball valves, Cameron's AOP brand offers a wide range of threaded-end and flanged-end floating ball valves, threaded and flanged check valves, and needle valves.

Call Cameron, our field representatives or local distributors today for more information on how we can provide solutions for your production needs.

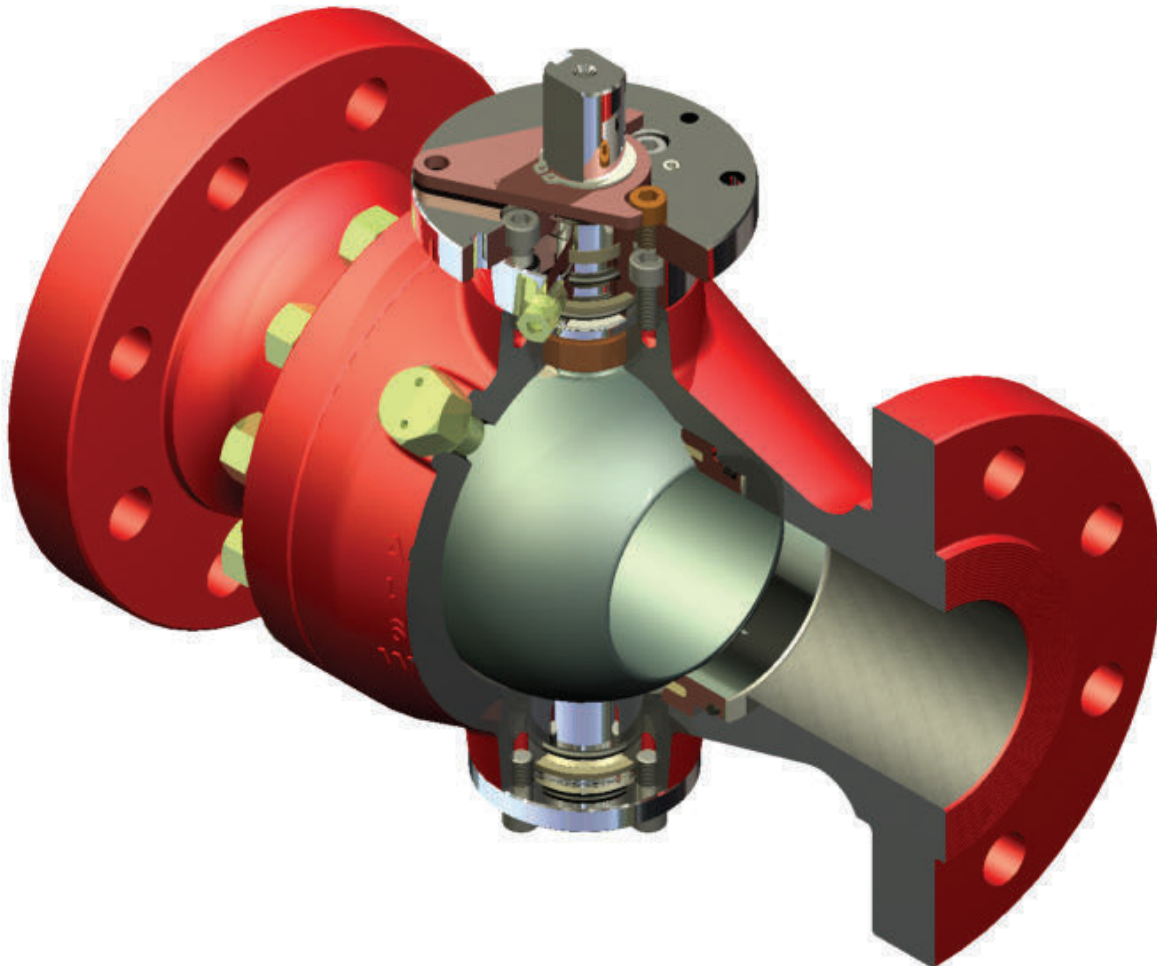

## FEATURES AND BENEFITS

The AOP Series D trunnion mounted ball valves offer a broad range of trim options. These include: stainless steel, low-temperature or high-temperature applications and special graphite seals.

The special graphite seals are provided to effectively prevent external leakage for fire-safe applications (conforms to API specifications 6FA or 607).

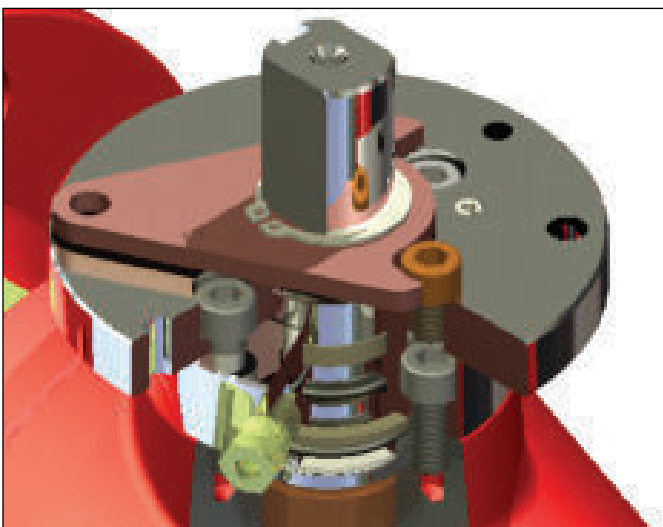
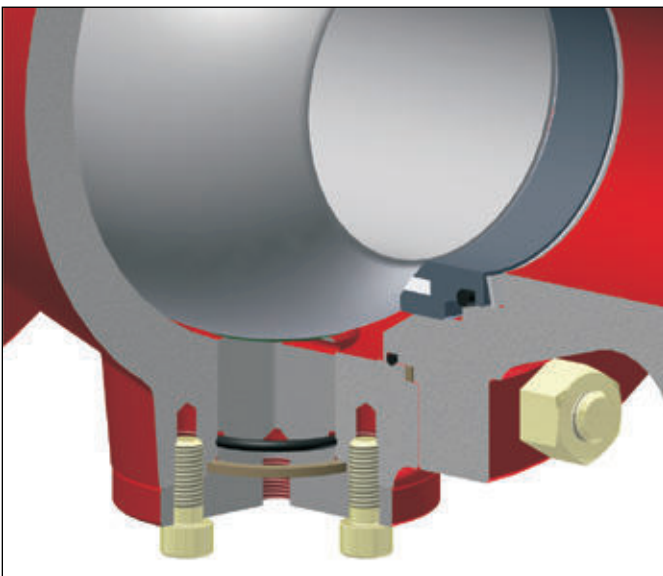

AOP's two-piece, end-entry, trunnion mounted ball valves are available in flanged connections with sizes ranging from 2" to 12" bore to ASME Class 900 and 2", 3" and 4" in API 1500 and 5000 pressure classes.

Operating temperatures range from -50° F to +350° F (-46° C to +175° C).

### Standard Features

- Double barrier stem seals
- Short coupled trunnions to reduce unit bearing loads and operating torque
- Fixed-position external stops
- Stem separate from the ball
- Trunnion mounted ball for ease of operation at high pressures
- NACE MR0175/ISO 15156
- Fire-tested in accordance with API 6FA or API 607
- Plastic polymer insert or elastomer (6" to 12") for seat sealing
- Metal-backed self-lubricating PTFE sleeve bearings and thrust washers reduce torque and extend service life
- Bolted construction permits disassembly on job site for repairs
- Standard valve trim is supplied with electroless nickel coating
- Fire-safe graphite rings for protection against external leakage (2", 3" and 4")
- Self-relieving seats to eliminate cavity pressure lock
- Double block and bleed standard
- Seat injection standard on 6" to 12" valves in ASME Class 150-900 and 2", 3" and 4" valves in ASME Class 1500, 2500 and 5000
- API 6D monogrammed

### Optional Features

- Sealing materials are available for various service conditions

# ASME Class 150-900, 2" through 6" x 4"

## VALVE ASSEMBLY

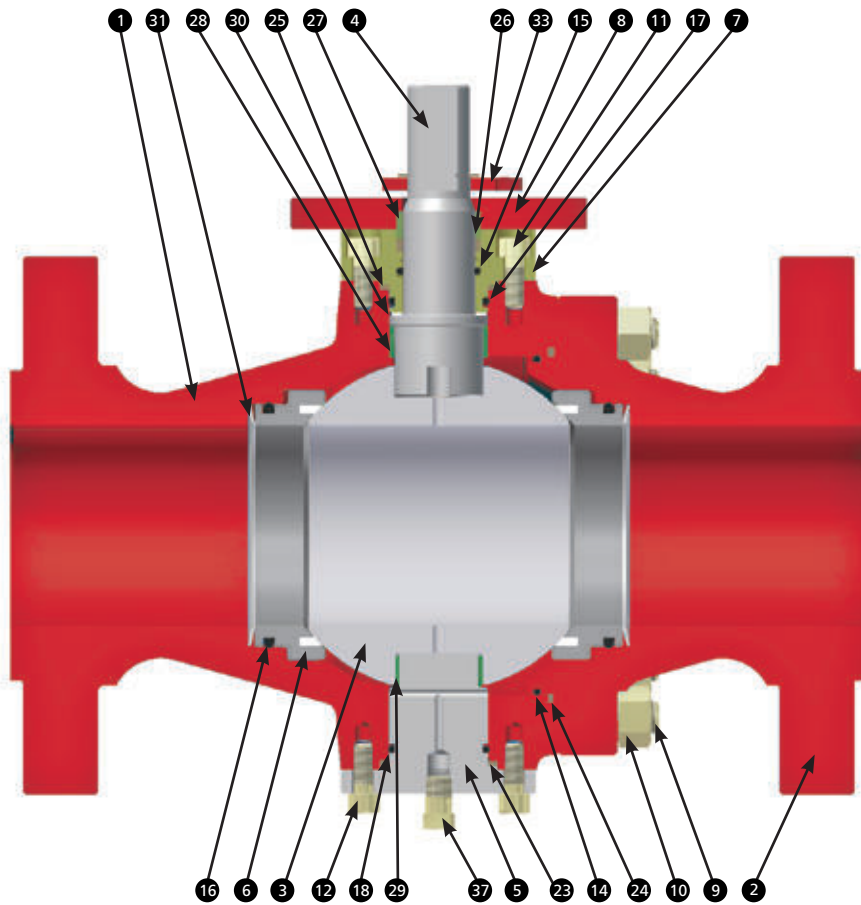
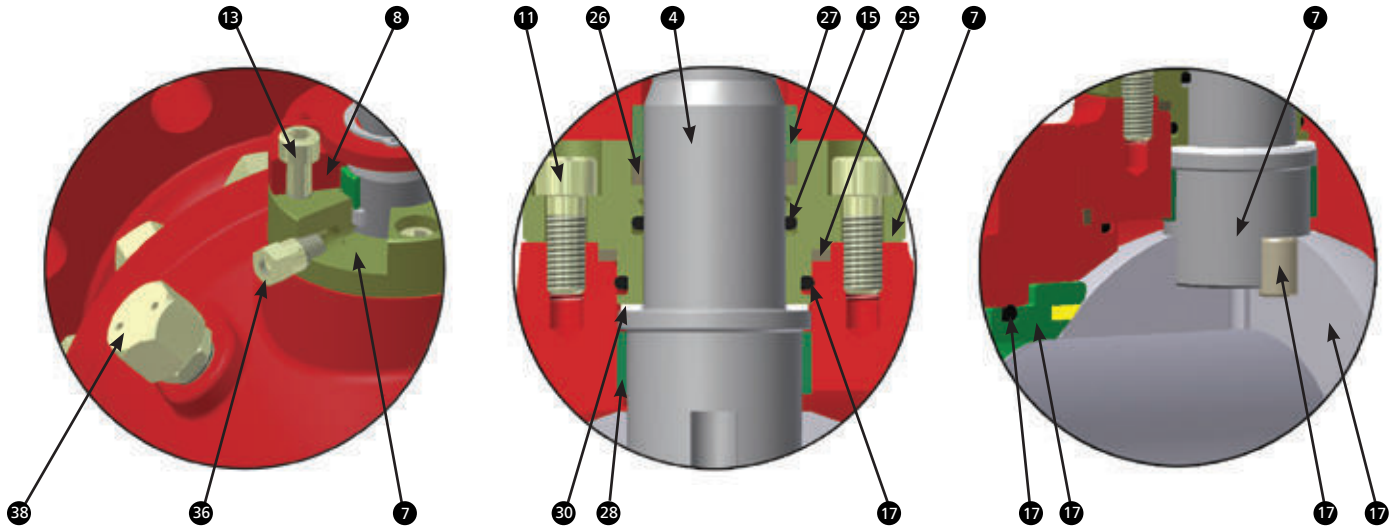

## MATERIALS OF CONSTRUCTION

Item	Part	Carbon Steel NACE	Stainless Steel NACE
1	Body	ASTM A216 WCC	ASTM A216 WCC
2	Closure	ASTM A216 WCC/A350 LF2	ASTM A216 WCC/A350 LF2
3	Ball	ASTM A350 LF2 1MIL ENP	ASTM A351 CF8M
4	Stem	ASTM 4140 1MIL ENP	ASTM A564-630
5	Lower Trunnion	ASTM 4140 1MIL ENP	ASTM A351 CF8M/A564-630
6	Seat Ring	ASTM A350 LF2 1MIL ENP w/insert	ASTM A351 CF8M w/insert
7	Gland Plate	ASTM A350 LF2	ASTM 350 LF2
8	Bearing Housing (Lever Op.)/Adapter Plate	ASTM A36/A350 LF2	ASTM A36/A350 LF2
9	Body Stud	ASTM A193 B7*	ASTM A193 B7*
10	Body Stud Nut	ASTM A194 2H*	ASTM A194 2H*
11	Gland Plate Capscrews	A574M	A574M
12	Lower Trunnion Capscrews	A574M	A574M
13	Bearing Housing (Lever Op.)/ Adapter Plate Capscrews	A574M	A574M
14	Closure O-ring	Fluorocarbon Elastomer	Fluorocarbon Elastomer
15	Stem O-ring	Fluorocarbon Elastomer	Fluorocarbon Elastomer
16	Seat Gasket O-ring	Fluorocarbon Elastomer	Fluorocarbon Elastomer
17	Gland Plate O-ring	Fluorocarbon Elastomer	Fluorocarbon Elastomer
18	Trunnion O-ring	Fluorocarbon Elastomer	Fluorocarbon Elastomer
19	Gland Plate Backup Ring (Class 900/1500 Only, Not Shown)	Nylon	Nylon
20	Stem Backup Ring (Class 900/1500 Only, Not Shown)	Nylon	Nylon
21	Lower Trunnion Backup Ring (Class 900/1500 Only, Not Shown)	Nylon	Nylon
22	Closure Backup Ring (Class 900/1500 Only, Not Shown)	Nylon	Nylon
23	Lower Trunnion Fire Seal	Graphoil	Graphoil
24	Closure Fire Seal	Graphoil	Graphoil
25	Gland Plate Fire Seal	Graphoil	Graphoil
26	Stem Fire Seal	Graphoil	Graphoil
27	Gland Bushing	ASTM A53 1MIL ENP	ASTM A53 1MIL ENP
28	Stem Bearing	Dry Bearing (Steel/Teflon)	Dry Bearing (Steel/Teflon)
29	Trunnion Bearing	Dry Bearing (Steel/Teflon)	Dry Bearing (Steel/Teflon)
30	Upper Thrust Washer	Dry Bearing (Steel/Teflon)	Dry Bearing (Steel/Teflon)
31	Seat Springs	Inconel X-750	Inconel X-750
32	Stem Drive Pins	AISI 4140	ASTM A564-630
33	Stop Plate (Lever Op.)	ASTM A569	ASTM A569
34	Torque Pin (Actuated, Not Shown)	AISI 1075	AISI 1075
35	Stem Key (Actuated)	AISI 1045/AISI 4140	AISI 1045/AISI 4140
36	Stem Fitting	AISI 1018/AISI 4140	ASTM A182 316/A564-630
37	Vent/Drain Fitting	AISI 1018/AISI 4140	ASTM A182 316/A564-630
38	Body Injection Fitting	AISI 1018/AISI 4140	ASTM A182 316/A564-630

- Notes: 1. Materials listed are minimum requirements. Cameron reserves the right to substitute materials listed on this page with alternate materials for the designated service.  
2. Component 8: Adapter plate required in lieu of bearing housing on actuated valves.  
3. Stainless steel locking device available upon request.  
\* Buried NACE bolting available upon request.

## DIMENSIONS AND WEIGHTS

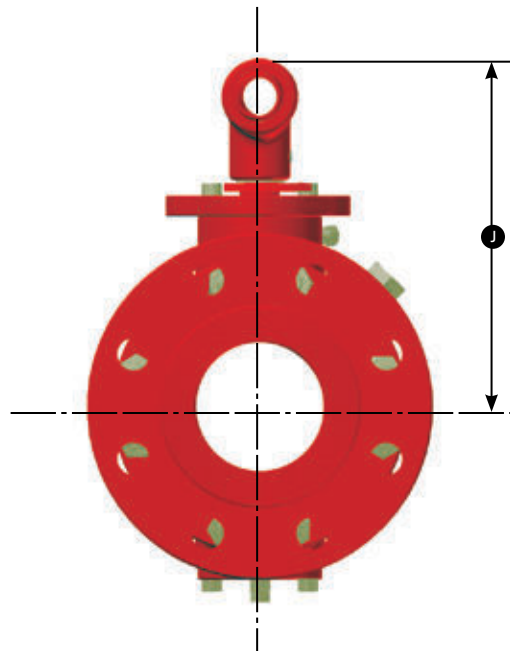
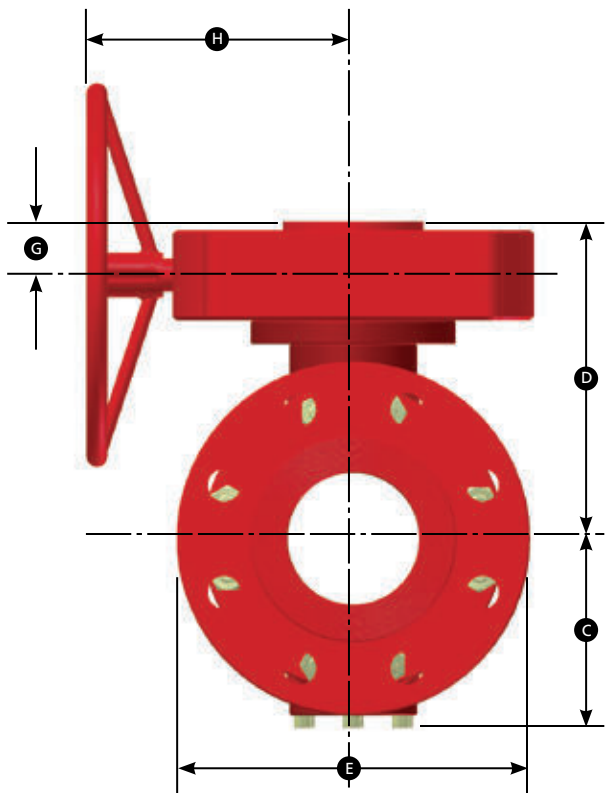
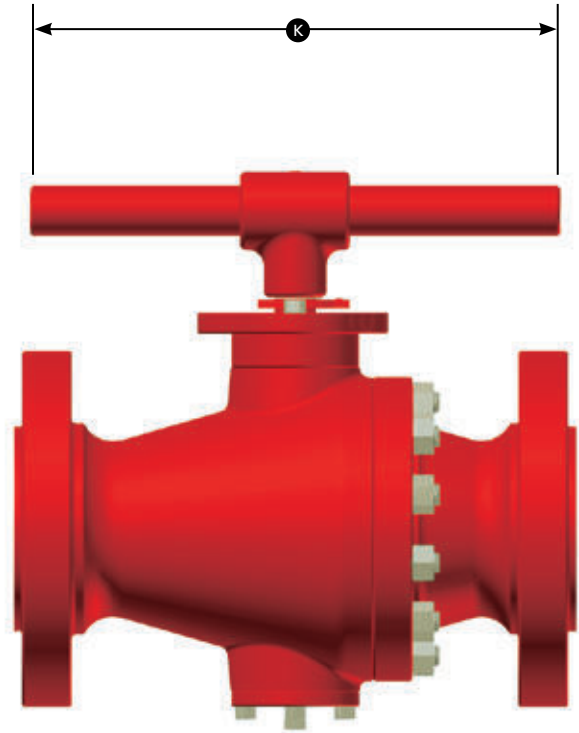
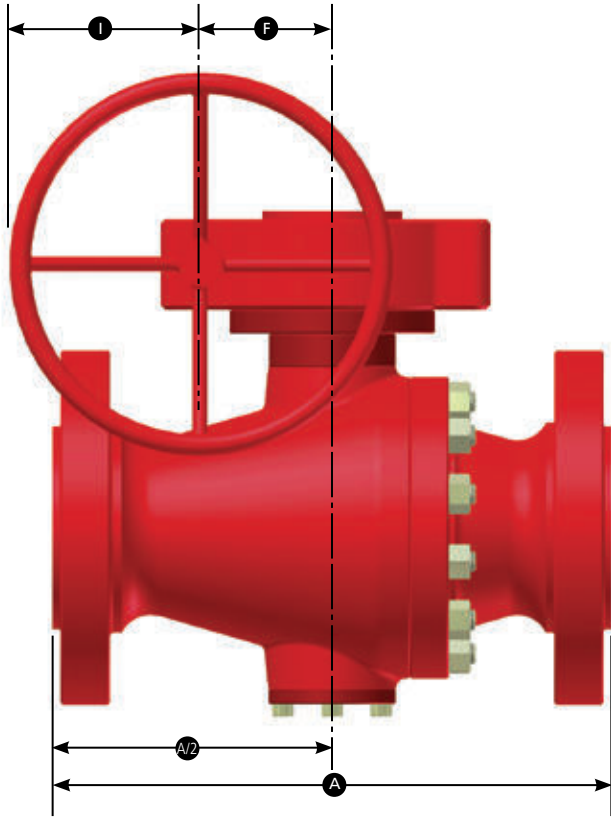

## DIMENSIONS AND WEIGHTS

## ASME CLASS 150

Working pressure – 285 psig (19.7 barg)

SIZE	in. (mm)	B	A (RF)		C	D	E	F	G	H	I	J	K	Weight lb	
														Valve (kg)	Gearbox (kg)
4	4	4	9	6-1/8	10-1/2	9-1/8	2-7/8	2-1/4	7-11/16	4	9-3/16	36	120	20	
	(100)	(102)	(229)	(156)	(267)	(232)	(71)	(57)	(195)	(102)	(233)	(914)	(54)	(9)	
6 x 4 x 6	4	10-1/2	6-1/8	10-1/2	11	2-7/8	2-1/4	7-11/16	4	9-3/16	36	135	20		
(150 x 100 x 150)	(102)	(267)	(156)	(267)	(279)	(71)	(57)	(195)	(102)	(233)	(914)	(61)	(9)		

## ASME CLASS 300

Working pressure – 740 psig (51.0 barg)

SIZE	in. (mm)	B	A (RF)		C	D	E	F	G	H	I	J	K	Weight lb	
														Valve (kg)	Gearbox (kg)
4	4	12	6-1/8	10-1/2	10	2.80	2-1/4	7-11/16	4	9-3/16	36	145	20		
	(100)	(102)	(305)	(156)	(267)	(254)	(71)	(57)	(195)	(102)	(233)	(914)	(66)	(9)	
6 x 4 x 6	4	15-7/8	6-1/4	10-1/2	12-1/2	2.80	2-1/4	7-11/16	4	9-3/16	36	200	20		
(150 x 100 x 150)	(102)	(403)	(159)	(267)	(318)	(71)	(57)	(195)	(102)	(233)	(914)	(91)	(9)		

## ASME CLASS 600

Working pressure – 1480 psig (102 barg)

SIZE	in. (mm)	B	A		C	D	E	F	G	H	I	J	K	Weight lb	
			RF	RTJ										Valve (kg)	Gearbox (kg)
2	2	11-1/2	11-5/8	4-1/8	8-1/2	6-1/2	2.05	2-1/4	8.42	4	6-1/2	24	50	11	
	(50)	(51)	(292)	(295)	(105)	(216)	(165)	(52)	(57)	(215)	(101)	(165)	(610)	(23)	(5)
3 x 2 x 3	2	14	14-1/8	4-1/8	8-1/2	8-1/4	2.05	2-1/4	8.42	4	6-1/2	24	70	11	
(75 x 50 x 75)	(51)	(356)	(359)	(105)	(216)	(210)	(52)	(57)	(215)	(101)	(165)	(610)	(32)	(5)	
3	3	14	14-1/8	5-1/8	9-1/2	8-1/4	2.80	2-1/4	11-3/16	6	8-1/4	36	100	20	
	(75)	(76)	(356)	(359)	(130)	(241)	(210)	(71)	(57)	(284)	(152)	(210)	(914)	(45)	(9)
4 x 3 x 4	3	17	17-1/8	5-7/16	9-1/2	10-3/4	2.80	2-1/4	11-3/16	6	8-1/4	36	155	20	
(100 x 75 x 100)	(76)	(432)	(435)	(138)	(241)	(273)	(71)	(57)	(284)	(152)	(210)	(914)	(70)	(9)	
4	4	17	17-1/8	6-1/8	10-1/2	10-3/4	2.80	2-1/4	11-3/16	6	9-3/16	36	190	20	
	(100)	(102)	(432)	(435)	(156)	(267)	(273)	(71)	(57)	(284)	(152)	(233)	(914)	(86)	(9)
6 x 4 x 6	4	22	22-1/8	7	10-1/2	14	2.80	2-1/4	11-3/16	6	9-3/16	36	295	20	
(150 x 100 x 150)	(102)	(559)	(562)	(178)	(267)	(356)	(71)	(57)	(284)	(152)	(233)	(914)	(134)	(9)	

## ASME CLASS 900

Working pressure – 2220 psig (153.1 barg)

SIZE	in. (mm)	B	A		C	D	E	F	G	H	I	J	K	Weight lb	
			RF	RTJ										Valve (kg)	Gearbox (kg)
2	2	14-1/2	14-5/8	4-7/16	8-3/4	8-1/2	2.80	2-1/4	11-3/16	6	6-7/8	24	100	20	
	(50)	(51)	(368)	(371)	(113)	(222)	(216)	(71)	(57)	(284)	(152)	(175)	(610)	(45)	(9)
3 x 2 x 3	2	15	15-1/8	4-3/4	8-3/4	9-1/2	2.80	2-1/4	11-3/16	6	6-7/8	24	120	20	
(75 x 50 x 75)	(51)	(381)	(384)	(121)	(222)	(241)	(71)	(57)	(284)	(152)	(175)	(610)	(54)	(9)	
3	3	15	15-1/8	5-9/16	10	9-1/2	2.80	2-1/4	11-3/16	6	8-3/4	36	150	20	
	(75)	(76)	(381)	(384)	(141)	(254)	(241)	(71)	(57)	(284)	(152)	(222)	(914)	(68)	(9)
4 x 3 x 4	3	18	18-1/8	5-3/4	10	11-1/2	2.80	2-1/4	11-3/16	6	8-3/4	36	190	20	
(100 x 75 x 100)	(76)	(457)	(460)	(146)	(254)	(292)	(71)	(57)	(284)	(152)	(222)	(914)	(86)	(9)	
4	4	18	18-1/8	6-13/16	11-1/2	11-1/2	3.39	2-1/4	10-3/4	9-7/8	10-1/4	48	260	30	
	(100)	(102)	(457)	(460)	(173)	(292)	(292)	(86)	(57)	(273)	(251)	(260)	(1219)	(118)	(14)
6 x 4 x 6	4	24	24-1/8	7-1/2	11-1/2	15	3.39	2-1/4	10-3/4	9-7/8	10-1/4	48	350	30	
(150 x 100 x 150)	(102)	(610)	(613)	(191)	(292)	(381)	(86)	(57)	(273)	(251)	(260)	(1219)	(159)	(14)	

## TOPWORKS DIMENSIONS

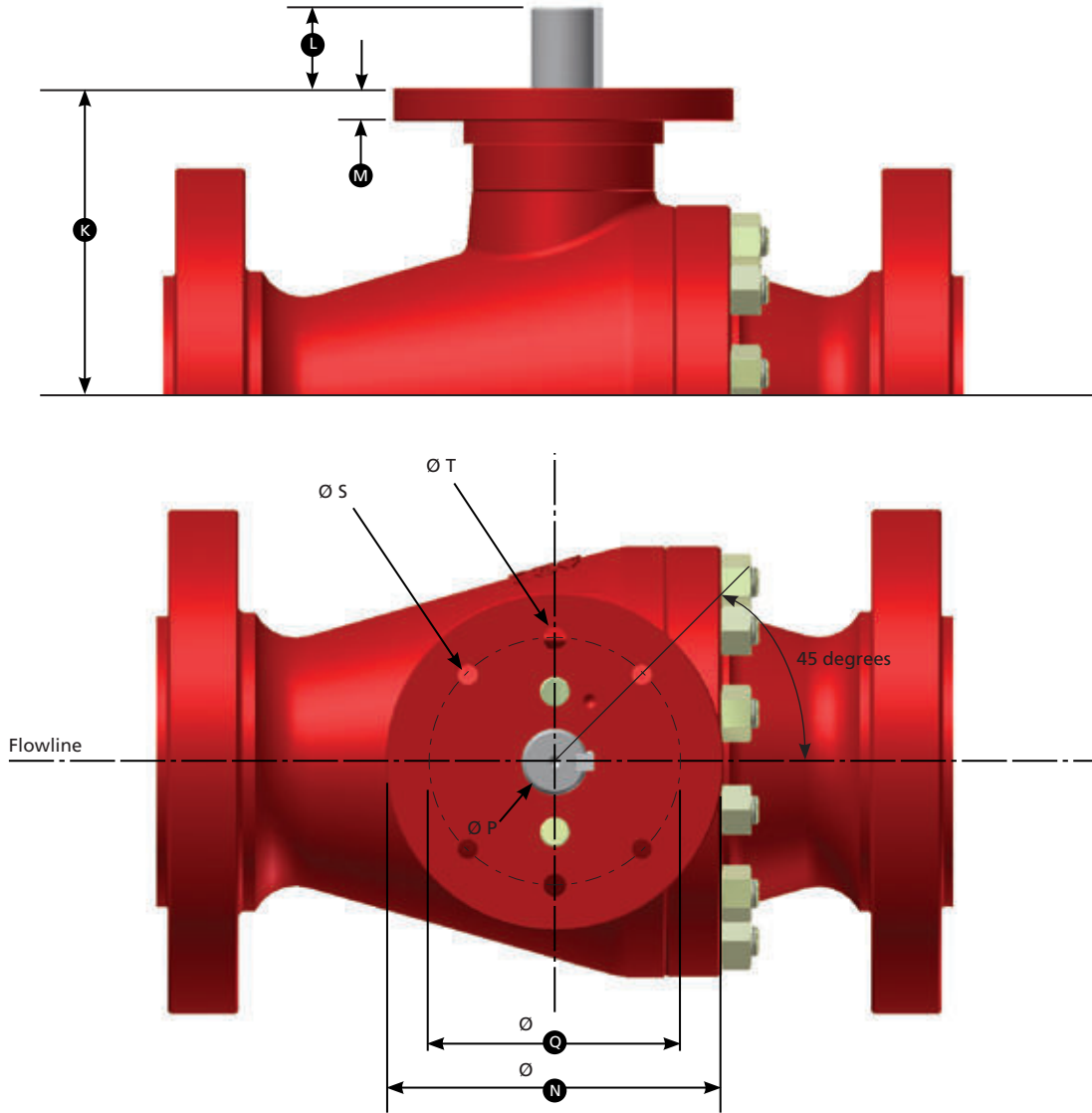

Ball Size	in. (mm)	ASME Class	K	L	M	N	P (+0/-0.003)	Q	Orientation	S	T	Sq. Key Size
2 (50)		150/600	4.65 (118.00)	1.378 (35.00)	0.39 (10.00)	4.75 (120.60)	0.983 (24.97)	4.016 (102.01)	4 Holes	0.35 (9.00)	0.315 (10.00)	8 mm x 40 mm
2 (50)		900/1500	4.93 (125.10)	1.378 (35.00)	0.66 (17.00)	5.50 (139.00)	0.983 (24.97)	4.625 (117.50)	4 Holes	0.44 (11.00)	0.315 (10.00)	8 mm x 40 mm
3 (75)		150/600	5.67 (144.00)	1.969 (50.00)	0.71 (18.00)	5.50 (139.00)	1.180 (29.97)	4.625 (117.50)	4 Holes	0.44 (11.00)	0.315 (10.00)	8 mm x 55 mm
3 (75)		900/1500	6.08 (154.50)	2.165 (55.00)	0.71 (18.00)	5.78 (146.00)	1.377 (34.97)	4.921 (125.00)	4 Holes	0.44 (11.00)	0.315 (10.00)	10 mm x 60 mm
4 (100)		150/600	6.61 (168.00)	2.165 (55.00)	0.71 (18.00)	5.78 (146.00)	1.377 (34.97)	4.921 (125.00)	4 Holes	0.44 (11.00)	0.315 (10.00)	10 mm x 60 mm
4 (100)		900/1500	7.54 (191.50)	2.165 (55.00)	0.79 (20.00)	7.03 (178.60)	1.574 (39.97)	6.00 (152.40)	4 Holes	0.51 (13.00)	0.472 (12.00)	10 mm x 60 mm

ASME Class 150-900, 6" through 12"

VALVE ASSEMBLY

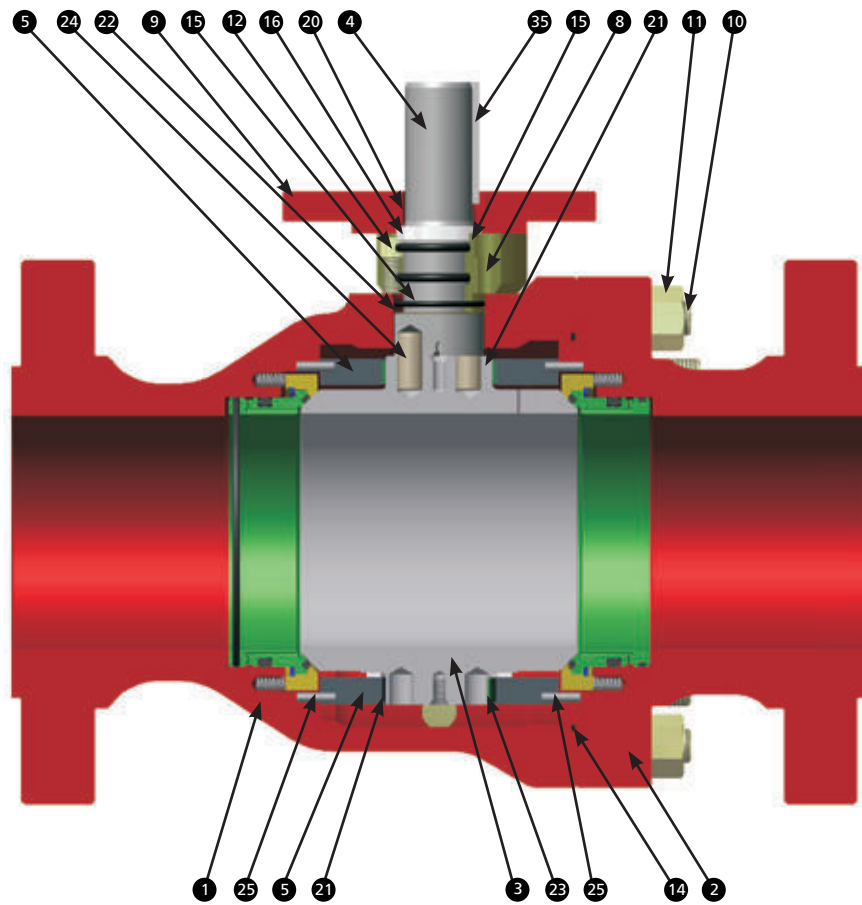
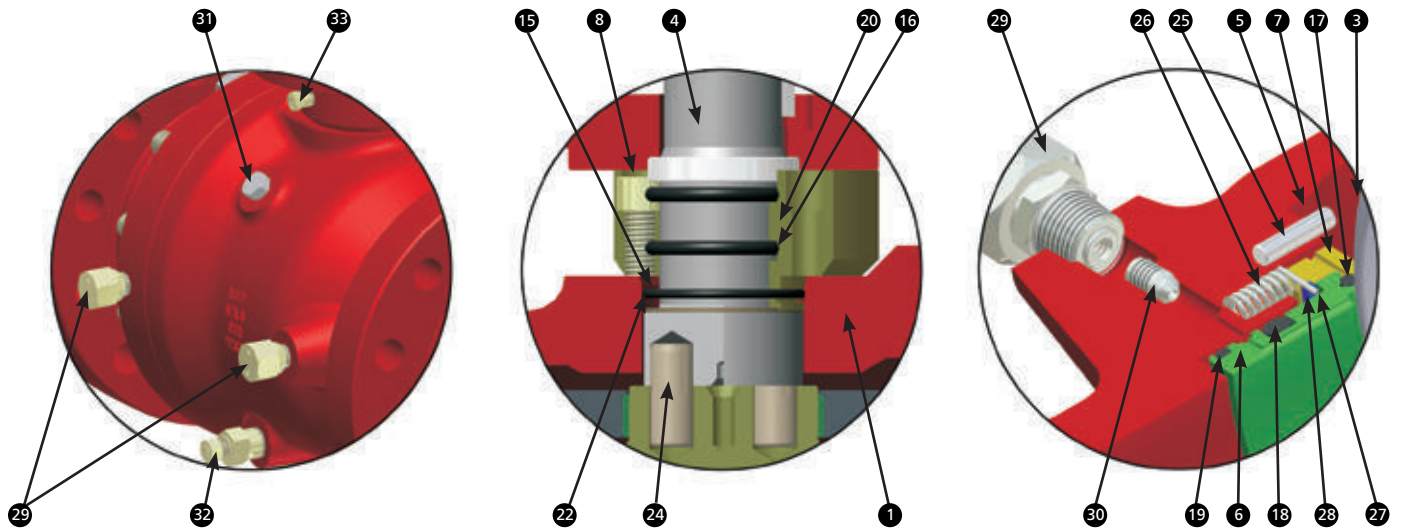

## MATERIALS OF CONSTRUCTION

Item	Part	Carbon Steel NACE	Stainless Steel NACE
1	Body	ASTM A216 WCC	ASTM A216 WCC
2	Closure	ASTM A216 WCC	ASTM A216 WCC
3	Ball	ASTM A350 LF2 1MIL ENP	ASTM A351 CF8M 1MIL ENP
4	Stem	AISI 4140 1MIL ENP	ASTM A564-630
5	Bearing Retainer	ASTM A36/A350 LF2	ASTM A36/A350 LF2
6	Inner Seat Ring	ASTM A350 LF2 1MIL ENP	ASTM A351 CF8M 1MIL ENP
7	Outer Seat Ring	ASTM A350 LF2 1MIL ENP	ASTM A351 CF8M
8	Gland Plate	ASTM A350 LF2	ASTM A350 LF2
9	Adapter Plate	ASTM A36/A350 LF2	ASTM A36/A350 LF2
10	Body Stud	ASTM A193 B7*	ASTM A193 B7*
11	Body Stud Nut	ASTM A194 2H*	ASTM A194 2H*
12	Gland Plate Capscrew	A574M	A574M
13	Adapter Plate Capscrew (Not Shown)	A574M	A574M
14	Closure O-ring	Fluorocarbon Elastomer	Fluorocarbon Elastomer
15	Gland Plate O-ring	Fluorocarbon Elastomer	Fluorocarbon Elastomer
16	Stem O-ring	Fluorocarbon Elastomer	Fluorocarbon Elastomer
17	Seat Seal O-ring	Fluorocarbon Elastomer	Fluorocarbon Elastomer
18	Seat Gasket O-ring	Fluorocarbon Elastomer	Fluorocarbon Elastomer
19	Grease Seal O-ring	Fluorocarbon Elastomer	Fluorocarbon Elastomer
20	Gland Bushing	ASTM A53 1MIL ENP	ASTM A53 1MIL ENP
21	Stem Trunnion Bearing	Dry Bearing (Steel/Teflon)	Dry Bearing (Steel/Teflon)
22	Upper Thrust Washer	Dry Bearing (Steel/Teflon)	Dry Bearing (Steel/Teflon)
23	Lower Thrust Washer	Dry Bearing (Steel/Teflon)	Dry Bearing (Steel/Teflon)
24	Stem Drive Pin	AISI 4140	ASTM A564-630
25	Bearing Retaining Pin	AISI 4140	AISI 4140
26	Seat Spring	Inconel X-750	Inconel X-750
27	Seat Lock Ring Spring Pin	Stainless Steel	Stainless Steel
28	Seat Lock Ring	304 SS	304 SS
29	Seat Injection Fitting	AISI 1018/AISI 4140	ASTM A182 316/A564-630
30	Internal Check Valve	ASTM A182 316/K-Monel	ASTM A182 316/K-Monel
31	Vent Plug	ASTM A105	ASTM A182 316
32	Drain Fitting	AISI 1018/AISI 4140	ASTM A182 316/A564-630
33	Stem Fitting	AISI 1018/AISI 4140	ASTM A182 316/A564-630
34	Lifting Lug (Not Shown)	A36	A36
35	Stem Key	AISI 1045/AISI 4140	AISI 1045/AISI 4140
36	Torque Pin (Not Shown)	AISI 1075	AISI 1075

- Notes: 1. Materials listed are minimum requirements. Cameron reserves the right to substitute materials listed on this page with alternate materials for the designated service.  
 2. Alternate seal materials are available for special applications.  
 \* Buried NACE bolting available upon request.

## DIMENSIONS AND WEIGHTS

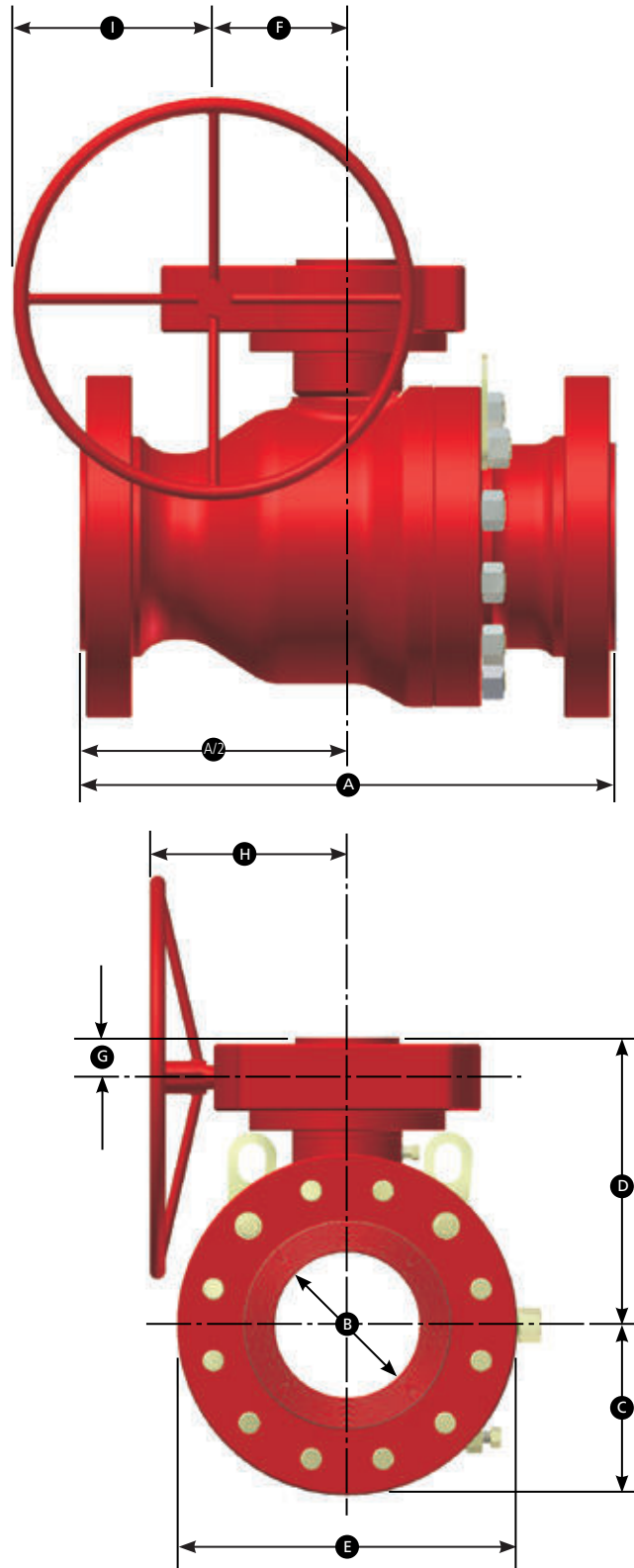

## DIMENSIONS AND WEIGHTS

### ASME CLASS 150

Working pressure – 285 psig (19.7 barg)

SIZE	in. (mm)	B	A		C	D	E	F	G	H	I	Weight lb	
			RF	RTJ								Valve (kg)	Gearbox (kg)
6	6.00	6.00	15.50	6.31	12.75	11.00	3.38	2.25	10.75	6.00	230	30	
(150)	(152)	(152)	(394)	(160)	(324)	(279)	(86)	(57)	(273)	(152)	(104)	(14)	
8 x 6 x 8	6.00	18.00	6.75	12.75	13.50	3.38	2.25	10.75	6.00	330	30		
(200 x 150 x 200)	(152)	(457)	(171)	(324)	(343)	(86)	(57)	(273)	(152)	(150)	(14)		
8	8.00	18.00	8.13	14.50	13.50	4.75	3.00	15.00	8.00	480	70		
(200)	(203)	(457)	(206)	(368)	(343)	(121)	(76)	(381)	(203)	(218)	(32)		
10 x 8 x 10	8.00	21.00	8.13	14.50	16.00	4.75	3.00	15.00	8.00	580	70		
(250 x 200 x 250)	(203)	(533)	(206)	(368)	(406)	(121)	(76)	(381)	(203)	(263)	(32)		
10	10.00	21.00	9.69	16.25	16.00	4.75	3.00	15.00	8.00	785	70		
(250)	(254)	(533)	(246)	(413)	(406)	(121)	(76)	(381)	(203)	(356)	(32)		
12 x 10 x 12	10.00	24.00	9.69	16.25	19.00	4.75	3.00	15.00	8.00	815	70		
(300 x 250 x 300)	(254)	(610)	(246)	(413)	(483)	(121)	(76)	(381)	(203)	(370)	(32)		
12	12.00	24.00	11.44	17.88	19.00	4.75	3.00	15.00	12.00	1115	70		
(300)	(305)	(610)	(291)	(454)	(483)	(121)	(76)	(381)	(305)	(506)	(32)		

### ASME CLASS 300

Working pressure – 740 psig (51.0 barg)

6	6.00	15.88	6.31	12.75	12.50	3.38	2.25	10.75	6.00	275	30
(150)	(152)	(403)	(160)	(324)	(318)	(86)	(57)	(273)	(152)	(125)	(14)
8 x 6 x 8	6.00	19.75	7.50	12.75	15.00	3.38	2.25	10.75	6.00	395	30
(200 x 150 x 200)	(152)	(502)	(191)	(324)	(381)	(86)	(57)	(273)	(152)	(179)	(14)
8	8.00	19.75	8.13	14.50	15.00	4.75	3.00	15.00	8.00	605	70
(200)	(203)	(502)	(206)	(368)	(381)	(121)	(76)	(381)	(203)	(274)	(32)
10 x 8 x 10	8.00	22.38	8.75	14.50	17.50	4.75	3.00	15.00	8.00	655	70
(250 x 200 x 250)	(203)	(568)	(222)	(368)	(445)	(121)	(76)	(381)	(203)	(297)	(32)
10	10.00	22.38	9.69	16.25	17.50	4.75	3.00	15.00	8.00	915	70
(250)	(254)	(568)	(246)	(413)	(445)	(121)	(76)	(381)	(203)	(415)	(32)
12 x 10 x 12	10.00	25.50	10.25	16.25	20.50	4.75	3.00	15.00	8.00	1315	70
(300 x 250 x 300)	(254)	(648)	(260)	(413)	(521)	(121)	(76)	(381)	(203)	(596)	(32)
12	12.00	25.50	11.44	17.88	20.50	4.75	3.00	15.00	12.00	1390	70
(300)	(305)	(648)	(291)	(454)	(521)	(121)	(76)	(381)	(305)	(630)	(32)

### ASME CLASS 600

Working pressure – 1480 psig (102 barg)

SIZE	in. (mm)	B	A		C	D	E	F	G	H	I	Weight lb	
			RF	RTJ								Valve (kg)	Gearbox (kg)
6 x 6	6.00	6.00	22.00	22.13	7.00	12.75	14.00	3.38	2.25	12.00	10.00	440	30
(150 x 150)	(152)	(152)	(559)	(562)	(178)	(324)	(356)	(86)	(57)	(305)	(254)	(200)	(14)
8 x 6	6.00	26.00	26.13	8.25	12.75	16.50	3.38	2.25	12.00	10.00	545	30	
(200 x 150)	(152)	(660)	(664)	(210)	(324)	(419)	(86)	(57)	(305)	(254)	(247)	(14)	
8 x 8	8.00	26.00	26.13	8.25	15.75	16.50	4.75	3.00	15.25	12.00	730	70	
(200 x 200)	(203)	(660)	(664)	(210)	(400)	(419)	(121)	(76)	(387)	(305)	(331)	(32)	
10 x 8	8.00	31.00	31.13	10.00	15.75	20.00	4.75	3.00	15.25	12.00	880	70	
(250 x 200)	(203)	(787)	(791)	(254)	(400)	(508)	(121)	(76)	(387)	(305)	(399)	(32)	
10 x 10	10.00	31.00	31.13	10.00	17.38	20.00	4.75	3.00	15.25	12.00	1240	70	
(250 x 250)	(254)	(787)	(791)	(254)	(441)	(508)	(121)	(76)	(387)	(305)	(562)	(32)	
12 x 10	10.00	33.00	33.13	11.00	17.38	22.00	4.75	3.00	15.25	12.00	1280	70	
(300 x 250)	(254)	(838)	(841)	(279)	(441)	(559)	(121)	(76)	(387)	(305)	(581)	(32)	
12 x 12	12.00	33.00	33.13	11.50	19.00	22.00	4.75	3.00	17.56	12.00	1675	88	
(300 x 300)	(305)	(838)	(841)	(292)	(483)	(559)	(121)	(76)	(446)	(305)	(760)	(40)	

### ASME CLASS 900

Working pressure – 2220 psig (153.1 barg)

6	6.00	24.00	24.13	7.50	14.50	15.00	5.13	3.00	15.25	10.00	555	70
(150)	(152)	(610)	(613)	(191)	(368)	(381)	(130)	(76)	(387)	(254)	(252)	(32)
8 x 6 x 8	6.00	29.00	29.13	9.25	14.50	18.50	5.13	3.00	15.25	10.00	755	70
(200 x 150 x 200)	(152)	(737)	(740)	(235)	(368)	(470)	(130)	(76)	(387)	(254)	(342)	(32)
8	8.00	29.00	29.13	9.25	15.63	18.50	5.13	3.00	15.25	12.00	1150	70
(200)	(203)	(737)	(740)	(235)	(397)	(470)	(130)	(76)	(387)	(305)	(522)	(32)
10 x 8 x 10	8.00	33.00	33.13	10.75	15.63	21.50	5.13	3.00	15.25	12.00	1200	70
(250 x 200 x 250)	(203)	(838)	(841)	(273)	(397)	(546)	(130)	(76)	(387)	(305)	(544)	(32)
10	10.00	33.00	33.13	10.75	17.38	21.50	8.31	3.00	17.56	12.00	1355	88
(250)	(254)	(838)	(841)	(273)	(441)	(546)	(211)	(76)	(446)	(305)	(615)	(40)
12 x 10 x 12	10.00	38.00	38.13	12.00	17.38	24.00	8.31	3.00	17.56	12.00	1705	88
(300 x 250 x 300)	(254)	(965)	(968)	(305)	(441)	(610)	(211)	(76)	(446)	(305)	(773)	(40)
12	12.00	38.00	38.13	12.00	19.00	24.00	8.31	3.00	17.56	12.00	2175	88
(300)	(305)	(965)	(968)	(305)	(483)	(610)	(211)	(76)	(446)	(305)	(987)	(40)

TOPWORKS DIMENSIONS

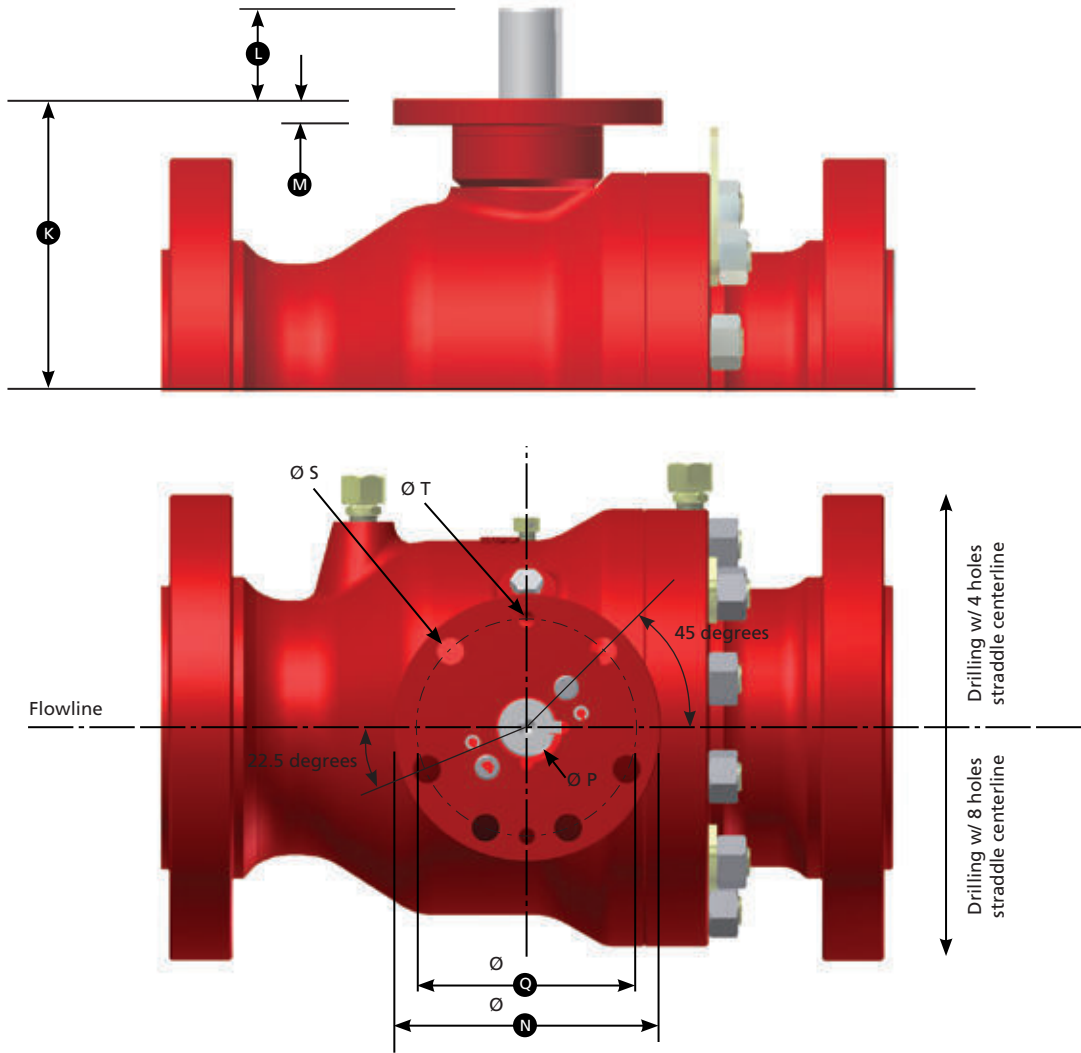

Ball Size	in. (mm)	ASME Class	K	L	M	N	P (+0/-0.003)	Q	Orientation	S	T	Sq. Key Size
6	(150)	150/600	8.76 (222.60)	2.717 (69.00)	13/16 (21.00)	8-1/16 (205.00)	1.748 (44.00)	6.50 (165.00)	4 Holes	13/16 (21.00)	0.472 (12.00)	3/8" x 3-1/4"
6	(150)	900	9.31 (236.50)	3.543 (90.00)	13/16 (21.00)	9-1/16 (230.00)	2.374 (60.30)	7.75 (197.00)	8 Holes	9/16 (14.00)	0.629 (16.00)	5/8" x 4"
8	(200)	150/900	10.50 (266.60)	3.543 (90.00)	13/16 (21.00)	9-1/16 (230.00)	2.374 (60.30)	7.75 (197.00)	8 Holes	9/16 (14.00)	0.629 (16.00)	5/8" x 4"
10	(250)	150/600	12.25 (311.10)	3.543 (90.00)	13/16 (21.00)	9-1/16 (230.00)	2.374 (60.30)	7.75 (197.00)	8 Holes	9/16 (14.00)	0.629 (16.00)	5/8" x 4"
10	(250)	900	12.25 (311.10)	3.740 (95.00)	13/16 (21.00)	9-1/16 (230.00)	2.374 (60.30)	7.75 (197.00)	8 Holes	9/16 (14.00)	0.629 (16.00)	5/8" x 4-3/8"
12	(300)	150/600	13.88 (352.40)	3.740 (95.00)	13/16 (21.00)	10-3/4 (273.00)	2.374 (60.30)	9.00 (228.60)	4 Holes	13/16 (21.00)	0.629 (16.00)	5/8" x 4-3/8"
12	(300)	900	13.88 (352.40)	3.740 (95.00)	13/16 (21.00)	10-3/4 (273.00)	2.874 (73.00)	9.00 (228.60)	4 Holes	13/16 (21.00)	0.629 (16.00)	3/4" x 4-5/16"

ASME Class 1500, 2" x 2" through 6" x 4"

VALVE ASSEMBLY

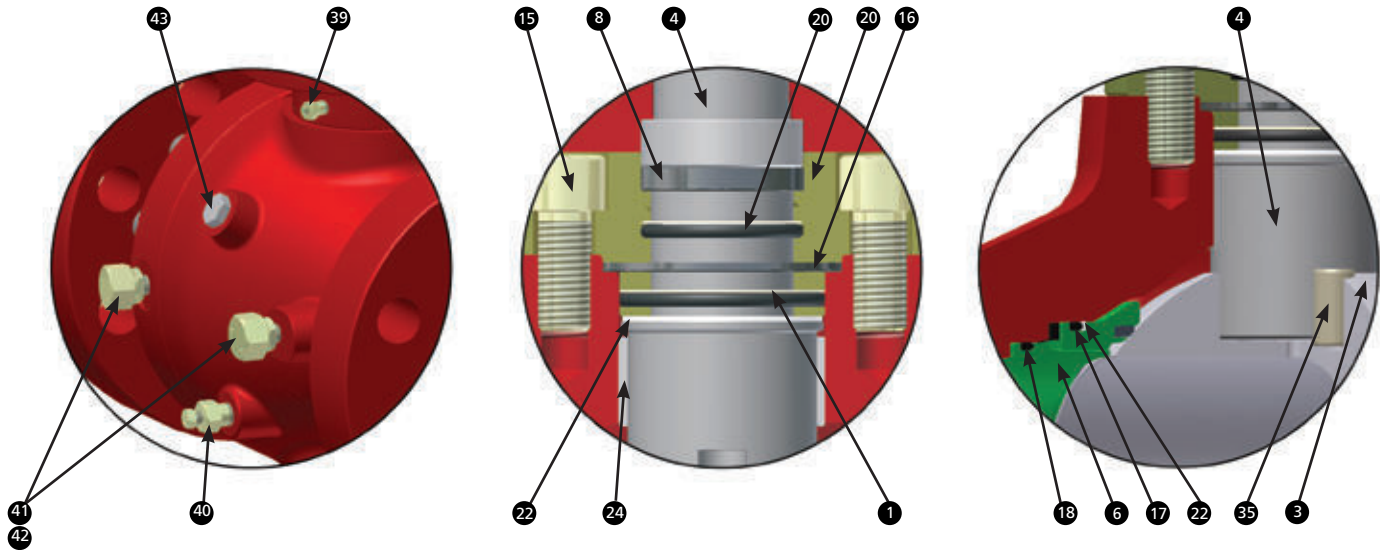

BARE STEM OPTION

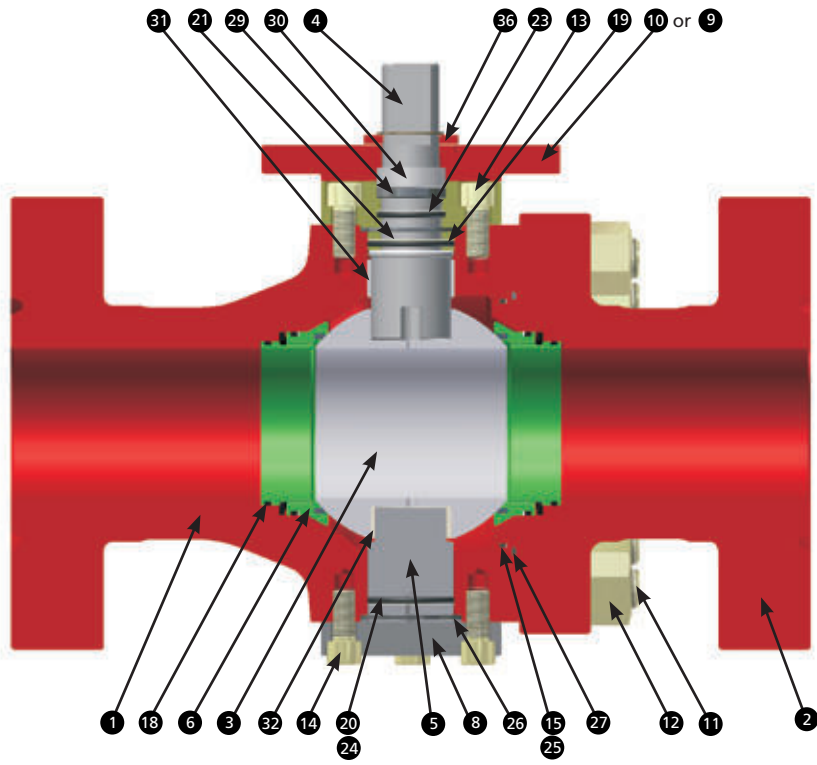
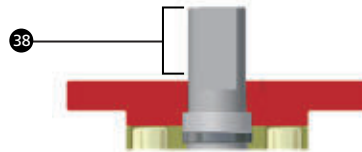

## MATERIALS OF CONSTRUCTION

Item	Part	Carbon Steel NACE	Stainless Steel NACE
1	Body	ASTM A216 WCC	ASTM A216 WCC
2	Closure-Adapter	ASTM A216 WCC	ASTM A216 WCC
3	Ball	AISI 4140/4130 1MIL ENP	ASTM A564-630
4	Stem	AISI 4140/4130 1MIL ENP	ASTM A564-630
5	Lower Trunnion	AISI 4140/4130 1MIL ENP	ASTM A564-630
6	Seat Ring	AISI 4140/4130 1MIL ENP with insert	ASTM A564-630 with insert
7	Gland Plate-Bonnet	ASTM A350 LF2	ASTM A350 LF2
8	Trunnion Cover	AISI 4130/4140	AISI 4130/4140
9	Bearing Housing (Lever Op.)	ASTM A36/A350 LF2	ASTM A36/A360 LF2
10	Adapter Plate (Actuated Valve)	ASTM A36/A350 LF2	ASTM A36/A360 LF2
11	Body Stud	ASTM A193 B7*	ASTM A193 B7*
12	Body Nut	ASTM A194 2H*	ASTM A194 2H*
13	Gland Plate Capscrews	A574M	A574M
14	Trunnion Cover Capscrews	A574M	A574M
15	Closure O-ring	Fluorocarbon Elastomer	Fluorocarbon Elastomer
16	Stem O-ring	Fluorocarbon Elastomer	Fluorocarbon Elastomer
17	Seat Gasket O-ring	Fluorocarbon Elastomer	Fluorocarbon Elastomer
18	Seat Secondary O-ring	Fluorocarbon Elastomer	Fluorocarbon Elastomer
19	Gland Plate O-ring	Fluorocarbon Elastomer	Fluorocarbon Elastomer
20	Trunnion O-ring	Fluorocarbon Elastomer	Fluorocarbon Elastomer
21	Gland Plate Backup Ring	Nylon	Nylon
22	Seat Gasket Backup Ring	Nylon	Nylon
23	Stem Backup Ring	Nylon	Nylon
24	Lower Trunnion Backup Ring	Nylon	Nylon
25	Closure Backup Ring	Nylon	Nylon
26	Lower Trunnion Fire Seal	Graphoil	Graphoil
27	Closure Fire Seal	Graphoil	Graphoil
28	Gland Plate Fire Seal	Graphoil	Graphoil
29	Stem Fire Seal	Graphoil	Graphoil
30	Gland Bushing	ASTM A53 1MIL ENP	ASTM A53 1MIL ENP
31	Stem Bearing	Dry Bearing (Steel/Teflon)	Dry Bearing (Steel/Teflon)
32	Trunnion Bearing	Dry Bearing (Steel/Teflon)	Dry Bearing (Steel/Teflon)
33	Stem Thrust Washer	Dry Bearing (Steel/Teflon)	Dry Bearing (Steel/Teflon)
34	Seat Wave Springs	Inconel X-750	Inconel X-750
35	Stem Drive Pins	AISI 4140	ASTM A564-630
36	Stop Plate (Lever Op.)	ASTM A569	ASTM A569
37	Torque Pin (Actuated, Not Shown)	AISI 1075	AISI 1075
38	Stem Key (Actuated)	AISI 1045/AISI 4140	AISI 1045/AISI 4140
39	Stem Fitting	AISI 1018/AISI 4140	ASTM A182 316/A564-630
40	Body Vent/Drain Fitting	AISI 1018/AISI 4140	ASTM A182 316/A564-630
41	Seat Injection Fitting	AISI 1018/AISI 4140	ASTM A182 316/A564-630
42	Internal Check Valve	AISI 4140/K-Monel	ASTM A182 316/K-Monel
43	Body Vent Plug	ASTM A105	ASTM A182 316

Notes: 1. Materials listed are minimum requirements. Cameron reserves the right to substitute materials listed on this page with alternate materials for the designated service.

2. Alternate seat, seal and ring materials are available for special applications.

3. Stainless steel locking device available upon request.

\* Buried NACE bolting available upon request.

## DIMENSIONS AND WEIGHTS

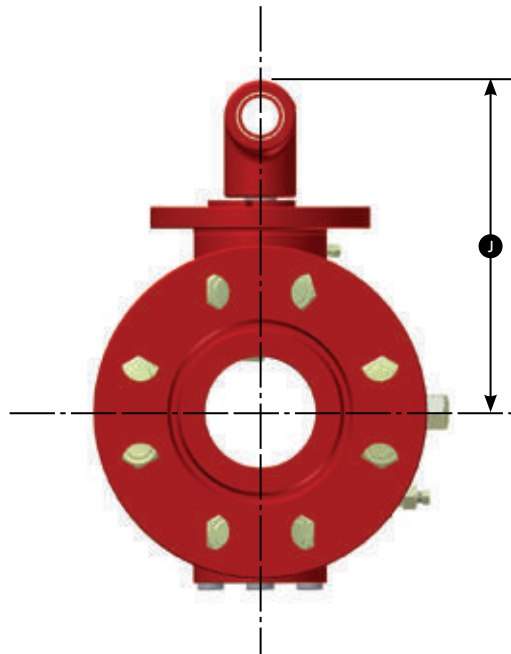
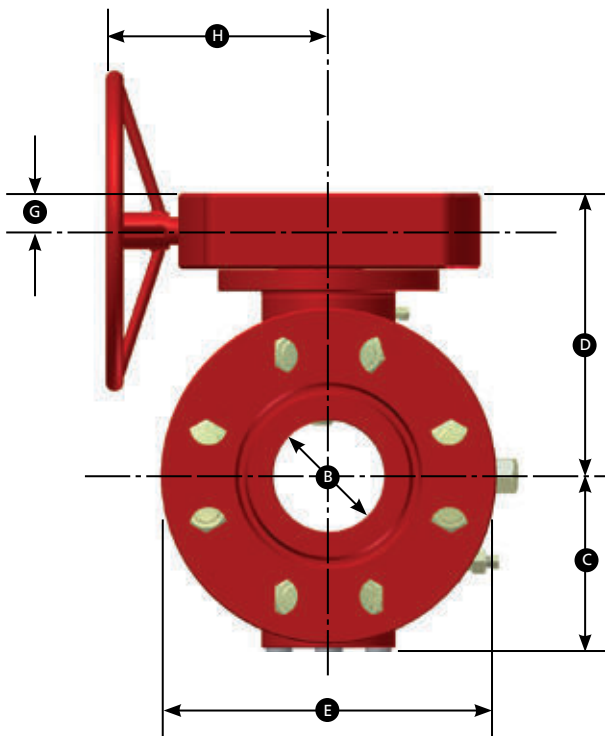
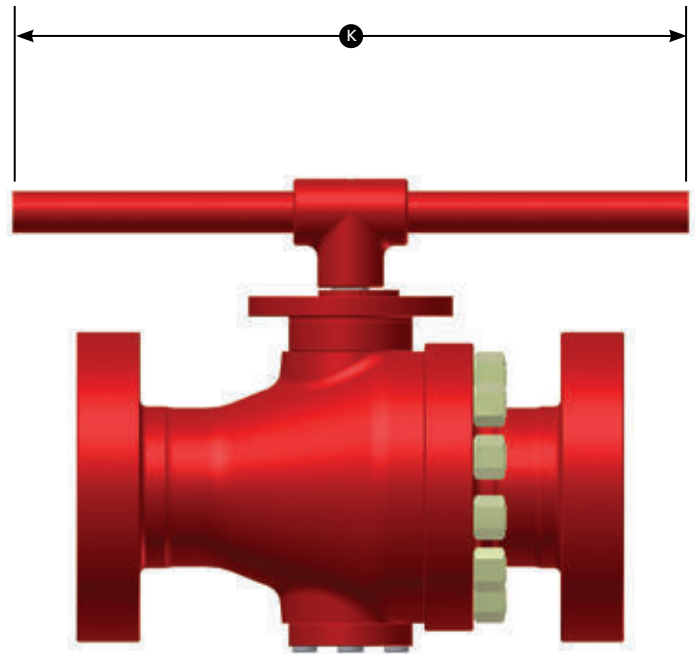
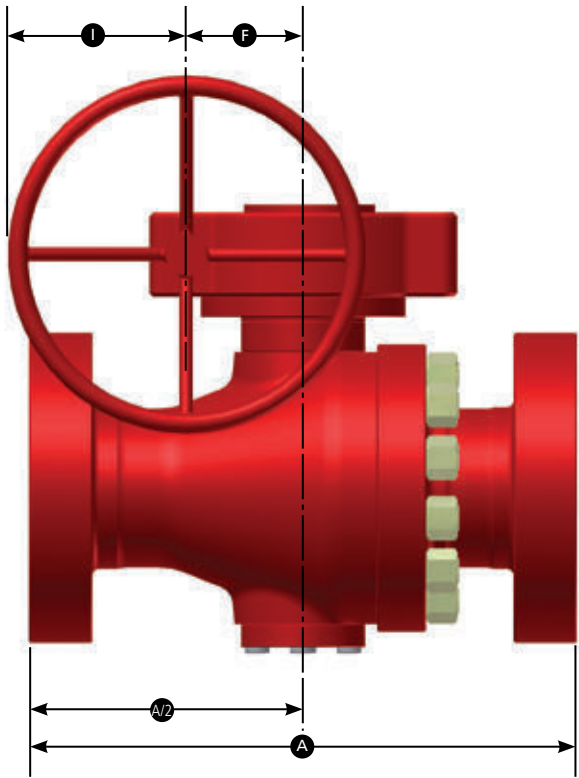

## DIMENSIONS AND WEIGHTS

## API 6D CLASS 1500

Size	in. (mm)	B	A		C	D	E	F	G	H	I	J	K	Weight lb	
			RF	RTJ										Valve (kg)	Gearbox (kg)
2 x 2 (50 x 50)	2.06 (52)	2.06 (52)	14.50 (368)	14.63 (372)	4.06 (103)	6.53 (166)	8.50 (216)	2.80 (71)	1.86 (47)	11.17 (284)	5.90 (150)	8.06 (205)	24.00 (610)	100 (45)	21 (9.5)
3 x 2 (80 x 50)	2.06 (52)	2.06 (52)	18.50 (470)	18.63 (473)	4.06 (103)	6.53 (166)	10.50 (267)	2.80 (71)	1.86 (47)	11.17 (284)	5.90 (150)	8.06 (205)	24.00 (610)	170 (77)	21 (9.5)
3 x 3 (80 x 80)	3.13 (79.5)	3.13 (79.5)	18.50 (470)	18.63 (473)	5.29 (134)	7.72 (196)	10.50 (267)	2.80 (71)	1.86 (47)	11.17 (284)	5.90 (150)	10.24 (260)	36.00 (914)	197 (89)	21 (9.5)
4 x 3 (100 x 80)	3.13 (79.5)	3.13 (79.5)	21.50 (546)	21.62 (549)	5.29 (134)	7.72 (196)	12.25 (311)	2.80 (71)	1.86 (47)	11.17 (284)	5.90 (150)	10.24 (260)	36.00 (914)	240 (109)	21 (9.5)
4 x 4 (100 x 100)	4.06 (103)	4.06 (103)	21.50 (546)	21.62 (549)	6.52 (166)	9.21 (234)	12.25 (311)	3.39 (86)	1.97 (50)	10.75 (273)	9.80 (249)	12.19 (310)	48.00 (1219)	360 (163)	30 (13.5)
6 x 4 (150 x 100)	4.06 (103)	4.06 (103)	27.75 (705)	28.00 (711)	6.52 (166)	9.21 (234)	15.50 (394)	3.39 (86)	1.97 (50)	10.75 (273)	9.80 (249)	12.19 (310)	48.00 (1219)	405 (184)	30 (13.5)

## TOPWORKS DIMENSIONS

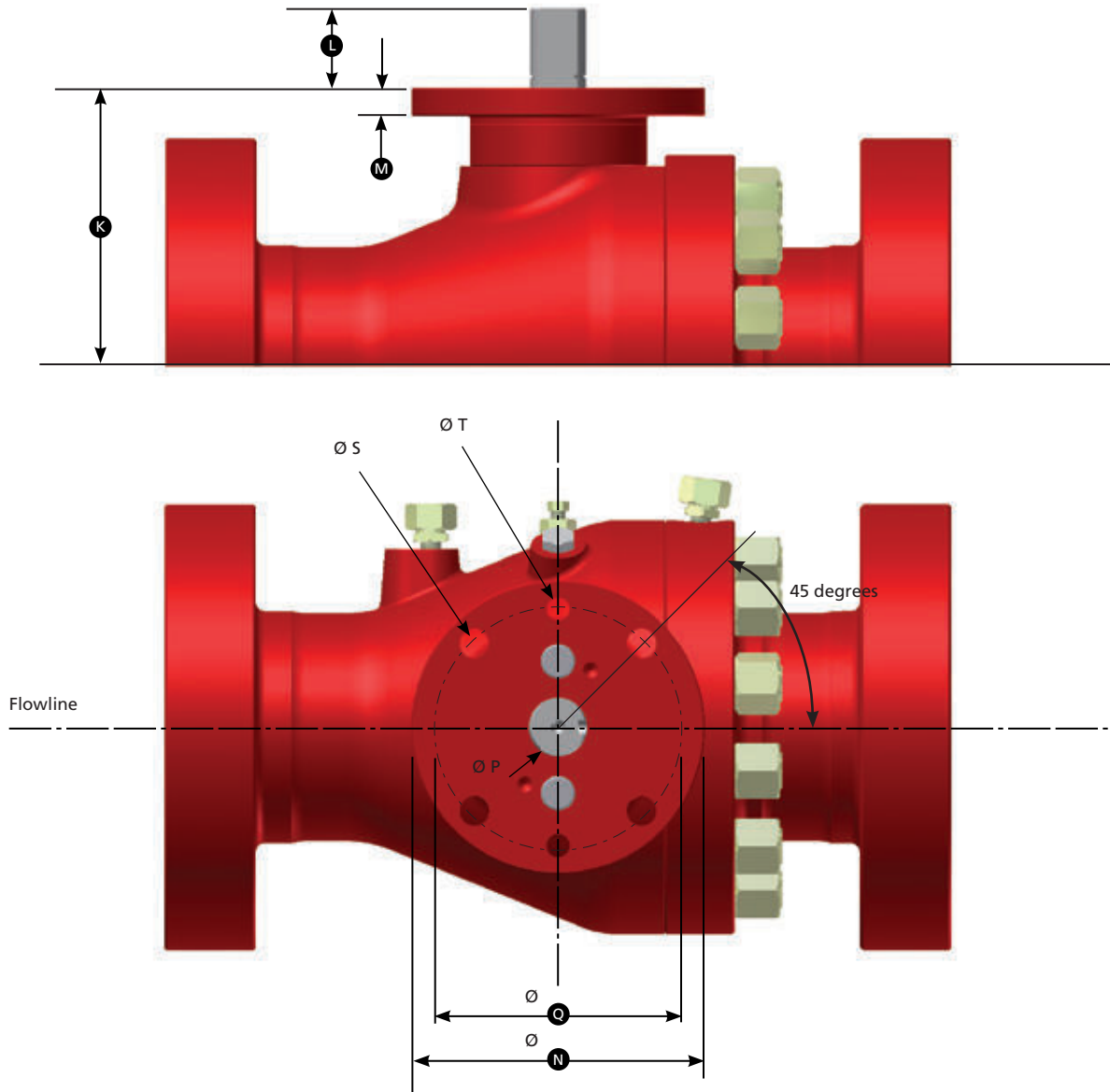

Size	in. (mm)	K	L	M	N	P (+0/-0.003)	Q	Orientation	S	T	Sq. Key Size
2 x 2 (50 x 50)		4.93 (125)	1.38 (35)	0.66 (17)	5.50 (139)	0.983 (24.97)	4.625 (117.50)	4 Holes	0.44 (11)	0.315 (10)	0.315 x 1.57 (8 x 40)
3 x 3 (80 x 80)		6.13 (156)	2.17 (55)	0.71 (18)	5.78 (146)	1.377 (34.97)	4.921 (125)	4 Holes	0.44 (11)	0.315 (10)	0.393 x 2.36 (10 x 60)
4 x 4 (100 x 100)		7.56 (192)	2.17 (55)	0.79 (21)	7.03 (178.60)	1.574 (39.97)	6.00 (152.40)	4 Holes	0.51 (13)	0.472 (12)	0.393 x 2.36 (10 x 60)

## ASME Class 2500 and 5000# MOP, 2" x 2" to 6" x 4"

### MATERIALS OF CONSTRUCTION

Part	Carbon Steel NACE	Stainless Steel NACE Trim
Body Class 2500	A216 Gr. WCC/A105	A216 Gr. WCC/A105
Body 5000# MOP	A487 Gr. 4	A487 Gr. 4
Tailpiece Class 2500	A216 Gr. WCC/A105	A216 Gr. WCC/A105
Tailpiece 5000# MOP	A487 Gr. 4	A487 Gr. 4
Studs	A193 Gr. B7M	A193 Gr. B7M Zinc Plate
Nuts	A194 Gr. 2HM	A194 Gr. 2HM Zinc Plate
Capscrews	A574M	A574M
Stem Stop	CS Zinc Plate	CS Zinc Plate
Stem Bearing	CS/Filled PTFE	SS/Filled PTFE
Trunnion Bearing	CS/Filled PTFE	SS/Filled PTFE
Stop Plate	Carbon Steel	Carbon Steel
Lever Handle	Ductile Iron	Ductile Iron
Lower Cover Plate	Carbon Steel	316 SS
Ball Class 2500	4130/4140 ENP	A564 Type 630 SS
Ball 5000# MOP	4130/4140 ENP	A564 Type 630 SS
Stem	4130/4140 ENP	A564 Type 630 SS ENP
Trunnion	4130/4140 ENP	A564 Type 630 SS ENP
Seat Rings Class 1500, 2500 and 5000# MOP	4130	A564 Type 630 SS
Seat Springs	B637 X-750	B637 X-750
Grounding Spring	Stainless Steel	Stainless Steel
Seat Face Seals Class 2500 and 5000# MOP	Nylon/PK	Nylon/PK
Stem Seal Class 2500 and 5000# MOP	PK	PK
Stem O-rings	HNBR/FKM	HNBR/FKM
Body/Tailpiece O-ring	HNBR/FKM	HNBR/FKM
Seat O-rings	HNBR/FKM	HNBR/FKM
Trunnion O-ring	HNBR/FKM	HNBR/FKM
O-ring Backup Ring Class 2500 and 5000# MOP	PK	PK

## DIMENSIONS AND WEIGHTS

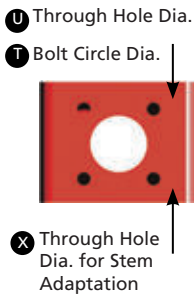
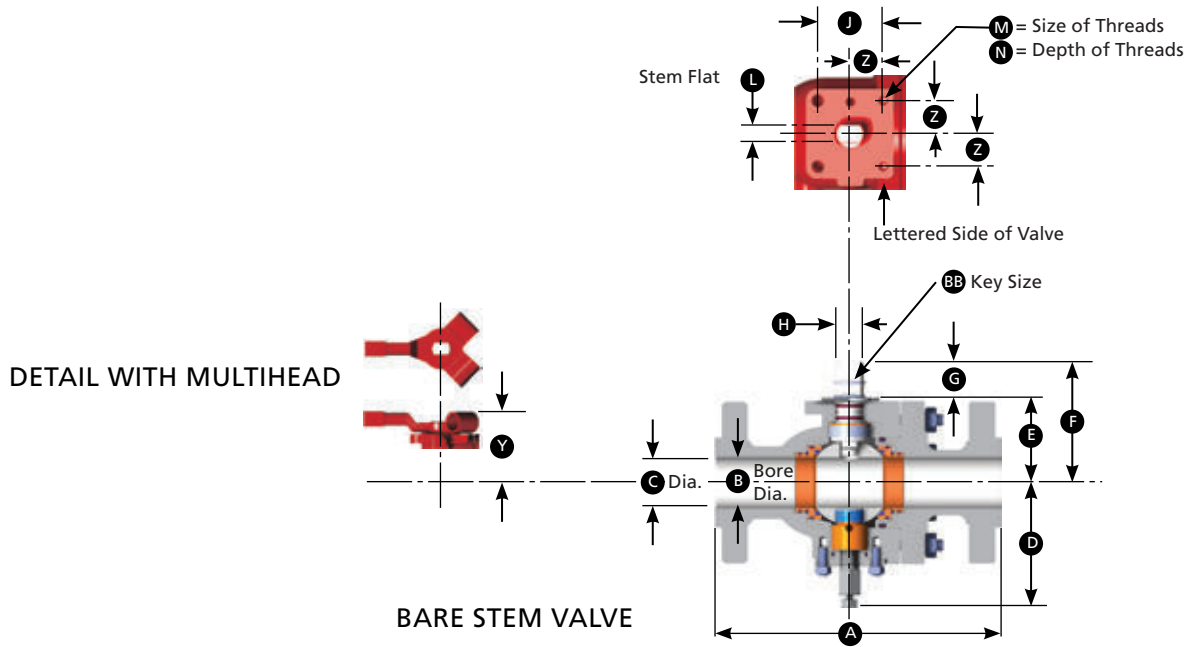

MOUNTING BRACKET  
TOP VIEW

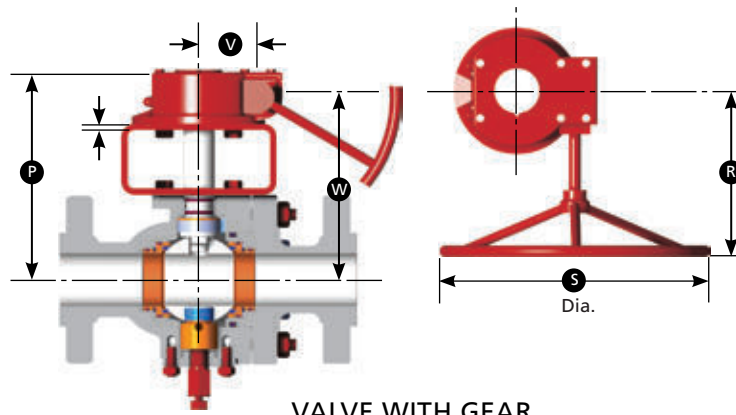

VALVE WITH GEAR

### FULL PORT API 5000# MOP

Size in. (mm)	A																			BB				
	RF	RJ	B	C	D	E	F	G	H	J	L	M	N	P	R	S	T	U	V		W	X	Y	Z
2-1/16 (52)	14.50 (368)	14.62 (371)	2.00 (51)	2.00 (51)	6.29 (160)	4.06 (103)	5.58 (142)	1.52 (39)	1.118 (28.40)	2.656 (67)	0.690 (17.53)	1/2-13UNC	0.50 (13)	10.34 (263)	8.12 (206)	10.00 (254)	4.92 (125)	0.56 (14)	2.80 (71)	8.75 (222)	3.00 (76)	6.40 (163)	1.328 (34)	-
3-1/8 (79)	18.50 (470)	18.62 (473)	3.00 (76)	3.00 (76)	7.29 (185)	4.75 (121)	6.96 (177)	2.21 (56)	1.496 (38.00)	3.375 (86)	0.994 (25.25)	1/2-13UNC	0.50 (13)	12.03 (306)	8.82 (224)	16.00 (406)	4.92 (125)	0.56 (14)	2.80 (71)	10.44 (265)	3.00 (76)	7.47 (190)	2.030 (52)	-
4-1/16 (103)	21.50 (546)	21.63 (549)	4.00 (102)	4.00 (102)	8.47 (215)	6.68 (184)	8.72 (221)	2.04 (52)	1.496 (38.00)	4.500 (114)	-	5/8-11UNC	0.63 (16)	14.12 (359)	9.73 (247)	16.00 (406)	6.50 (165)	0.56 (14)	3.39 (86)	12.47 (317)	3.00 (76)	9.44 (240)	2.250 (57)	0.375 (9.53)

### ASME CLASS 2500

2 (50)	17.75 (451)	17.88 (454)	1.78 (45)	1.78 (45)	6.29 (160)	4.06 (103)	5.68 (144)	1.62 (41)	0.995 (25.27)	3.500 (89)	-	1/2-13UNC	0.50 (13)	10.34 (263)	8.12 (206)	10.00 (254)	4.92 (125)	0.56 (14)	2.80 (71)	8.75 (222)	3.00 (76)	6.70 (170)	1.750 (44)	0.250 (6.35)
3 (75)	22.75 (578)	23.00 (584)	2.56 (65)	2.56 (65)	7.72 (196)	6.31 (160)	8.30 (211)	2.00 (51)	1.496 (38.00)	4.000 (102)	-	1/2-13UNC	0.50 (13)	13.75 (349)	9.73 (247)	16.00 (406)	5.51 (140)	0.56 (14)	3.39 (86)	12.10 (307)	3.00 (76)	9.07 (230)	2.030 (52)	0.375 (9.53)
4 (100)	26.50 (673)	26.88 (683)	3.53 (90)	3.53 (90)	8.47 (215)	7.25 (184)	10.05 (255)	2.80 (71)	1.683 (42.75)	4.625 (117)	-	5/8-11UNC	0.63 (16)	15.09 (383)	13.64 (346)	20.00 (508)	4.92 (125)	0.56 (14)	4.11 (104)	13.20 (335)	3.00 (76)	-	2.312 (59)	0.375 (9.53)
6 x 4 (150 x 100)	36.00 (914)	36.50 (927)	3.53 (90)	5.31 (135)	8.90 (226)	7.25 (184)	10.05 (255)	2.80 (71)	1.683 (42.75)	4.625 (117)	-	5/8-11UNC	0.63 (16)	15.09 (383)	13.64 (346)	20.00 (508)	4.92 (125)	0.56 (14)	4.11 (104)	13.20 (335)	3.00 (76)	-	2.312 (59)	0.375 (9.53)

# ASME Class 150-2500, 2" through 12"

## ASSEMBLY CODES / PART NUMBERS

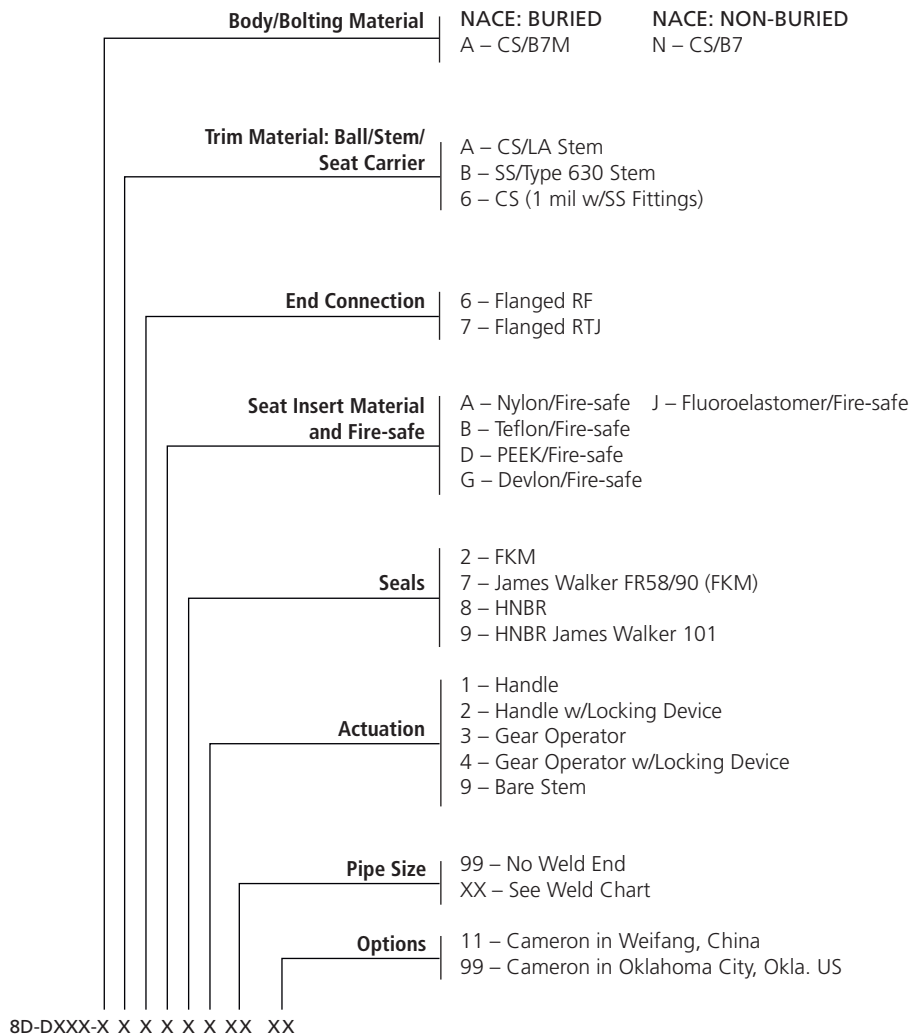

Size (in.)	2 FP	3 RP	3 FP	4 RP	4 FP	6 RP	6 FP	8 RP	8FP	10 RP	10 FP	12 RP	12 FP
150	-	-	-	-	D1N8	D1N9	D110	D111	D112	D113	D114	D115	D116
300	-	-	-	-	D3N8	D3N9	D310	D311	D312	D313	D314	D315	D316
600	D6N3	D6N5	D6N6	D6N7	D6N8	D6N9	D610	D611	D612	D613	D614	D615	D616
900	D9N3	D9N5	D9N6	D9N7	D9N8	D9N9	D910	D911	D912	D913	D914	D915	D916
1500	D8N3	D8N5	D8N6	D8N7	D8N8	D8N9	-	-	-	-	-	-	-
2500	D503	-	D506	-	D508	D509	-	-	-	-	-	-	-

# API 5000, 2-1/16" through 4-1/16"

## ASSEMBLY CODES / PART NUMBERS

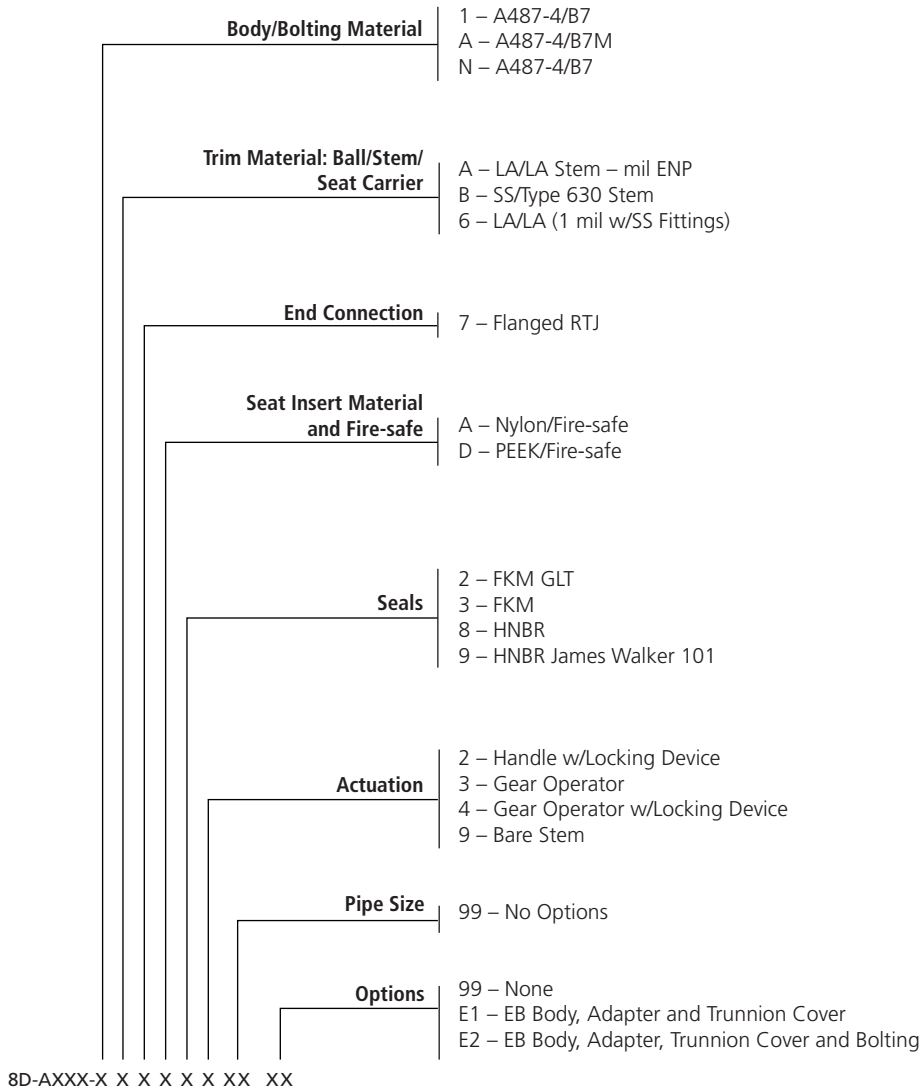

### BASE NUMBERS

Size (in.)	2-1/16 FP	3-1/8 FP	4-1/16 FP
API 5000	A2A5	A3A5	A4A5

PRESSURE TEMPERATURE DATA

PRESSURE TEMPERATURE CHART API 6D

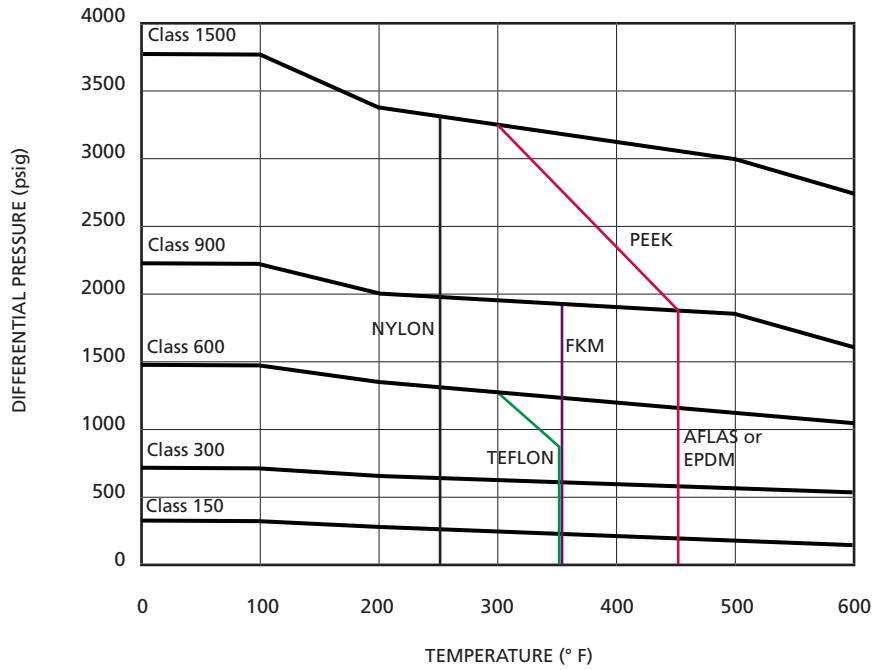

PRESSURE TEMPERATURE CHART API 5000

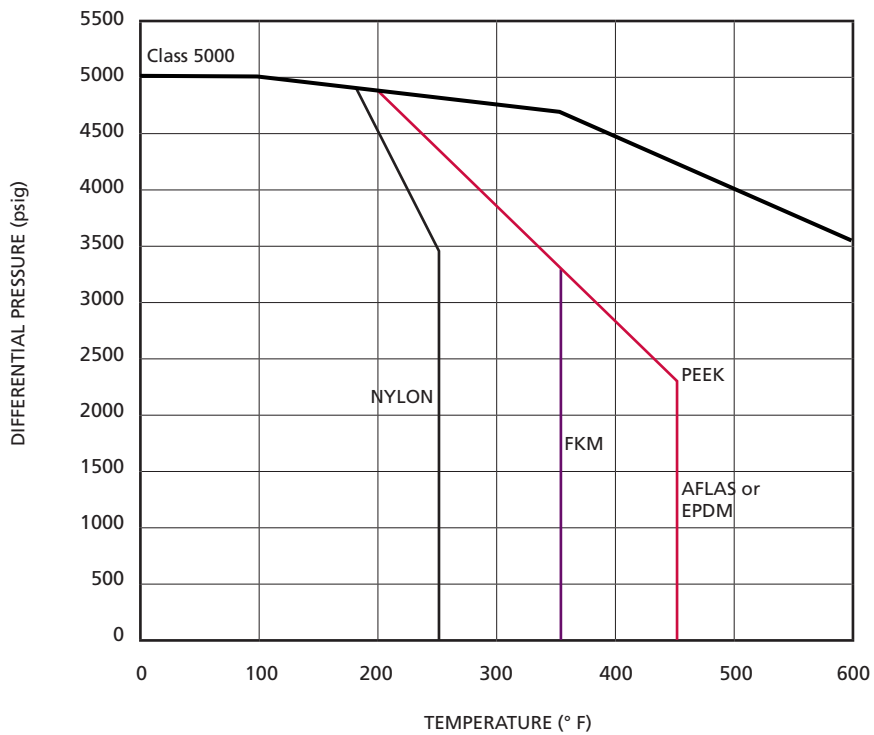

Information provided for general information only; consult factory for certified data.

## AOP Series D Trunnion Mounted Ball Valve

### SPECIFICATIONS AND CONFORMANCE

AOP trunnion mounted ball valves are designed, manufactured and tested in accordance with the following industry standards. Additional end-user or industry standards can be produced upon request.

#### ASME/ANSI – American Society of Mechanical Engineers/American National Standard Institute

B16.5	Steel pipe flanges
B16.10	Face-to-face and end-to-end dimensions of ferrous valve
B16.25	Butt welding ends
B16.34	Wall thickness
VIII, Div. 1	Bolting design

#### NACE – National Association of Corrosion Engineers

MR0175	Sulfide stress cracking resistant metallic materials for oilfield equipment
--------	---

#### API – American Petroleum Institute

Spec. 6D	Specification for pipeline valves
Spec. 6FA	Specification for fire testing of valves
Spec. Q1	Quality program

#### MSS – Manufacturers Standardization Society

SP - 6	Standard finishes for contact faces of pipe flanges and connecting end flanges of valves and fittings
SP - 25	Standard marking system for valves, fittings, flanges and unions

#### SERIES D – VALVE $C_v$

Size (in.)	2 FP	3 RP	3 FP	4 RP	4 FP	6 RP	6 FP	8 RP	8FP	10 RP	10 FP	12 RP	12 FP
Class 150	-	-	-	-	2377	740	5074	2020	10,103	4320	17,037	8820	26,163
Class 300	-	-	-	-	2067	755	5074	2010	10,103	4430	17,037	8900	26,163
Class 600	359	248	924	660	1773	785	4577	2030	8950	4210	14,324	7600	22,729
Class 900	321	184	892	625	1723	825	4383	2010	8476	4180	13,884	8750	21,186
Class 1500	325	223	815	618	1595	858	-	-	-	-	-	-	-
Class 2500	207	-	490	-	1014	-	-	-	-	-	-	-	-
API 5000	328	-	818	-	1598	858	-	-	-	-	-	-	-

The flow coefficient  $C_v$  of a valve is the flow rate of water (gallons/minute at 60° F) through a fully opened valve, with a pressure drop of 1 psi across the valve. To find the flow of a liquid or gas through a valve from the  $C_v$ , use the following formulas.

## FLOW COEFFICIENTS AND TORQUE VALUES

### FLOW EQUATIONS

Liquid Flow

QL = Flow rate of liquid (gallons/minute)

ΔP = Differential pressure across the valve (psig)

G = Specific gravity of liquid

$$QL = C_v \times \sqrt{\Delta P \div G}$$

Gas Flow (for non-critical flow)

Qg = Flow rate of gas (CFH)

ΔP = Differential pressure across the valve (psig)

P2 = Outlet pressure (psia)

G = Specific gravity of gas (air = 1)

$$Qg = 61 \times C_v \times \sqrt{(P_2 \times \Delta P) \div G}$$

### VALVE TORQUES AT MAX RATED PRESSURE at 100° F (in-lbs)

Size (in.)	2 FP	3 RP	3 FP	4 RP	4 FP	6 RP	6 FP	8 RP	8FP	10 RP	10 FP	12 RP	12 FP
Class 150	-	-	-	-	1099	1099	3864	3684	6408	6408	10,320	10,320	12,804
Class 300	-	-	-	-	1410	1410	5308	5308	10,634	10,634	14,733	14,733	19,421
Class 600	1128	1178	2064	2064	2628	2628	7956	7956	15,722	15,722	21,543	21,543	27,909
Class 900	1344	1344	2448	2448	4308	4308	11,076	11,076	20,322	20,322	31,372	31,372	38,032
Class 1500	1644	1644	3408	3408	6084	6084	-	-	-	-	-	-	-
Class 2500	3853	-	7972	-	13,224	-	-	-	-	-	-	-	-
API 5000	3163	-	6533	-	10,872	-	-	-	-	-	-	-	-
5000 psi													

Information provided for general information only; consult factory for certified data.

845 SE 29th Street  
Oklahoma, OK 73129  
USA

PO Box 94700  
Oklahoma, OK 73143  
USA

Tel 405.912.4446  
Fax 405.912.4440  
sales@aopind.com

Learn more about AOP at:

[www.c-a-m.com](http://www.c-a-m.com)  
[www.aopind.com](http://www.aopind.com)



**HSE Policy Statement**

At Cameron, we are committed ethically, financially and personally to a working environment where no one gets hurt, nothing gets harmed.

Cameron strives for continuous improvement in all aspects of our business. Cameron reserves the right to modify designs and specifications without notice or obligation. Nothing contained in this brochure is intended to extend any type of warranty, expressed or implied.