

# GROVE Valves

Durable, dependable technology in severe service conditions

# Contents

History .....	2
GROVE IST* Integrated Seat Technology Ball Valves .....	3
B4 Valve .....	4
B5 Valve .....	5
B7 Valve .....	6
B8 Valve .....	7
BT Valve .....	8
Actuation .....	9
Quality Management System .....	10
Qualification and Testing .....	11
Services for Valves and Actuation .....	12

Cameron is a leading provider of valves, valve automation, and measurement systems to the oil and gas industry. Rigorously tested, field-proven, and backed by our services team, Cameron GROVE\* valves are among the best known in the world.

### **GROVE valve legacy**

Established in 1934 by Marvin H. Grove, the Grove Regulator Co. became a prolific contributor to the global valve industry. Over a six-decade period, Grove Regulator registered and patented hundreds of valve and regulator designs and serviced a wide range of projects—from World War II submarines and NASA space launches to rocket engine development and deepsea transmission lines.

Early successes in providing valves to the gas transmission industry set the foundation for the brand's permanent presence in the oil and gas market. Cameron added the GROVE valve offering to its portfolio in 2005.

### **Ball valve portfolio**

The Cameron GROVE valve models include

- GROVE IST\* integrated seat technology ball valves
- side-entry ball valve models B4, B5, B7, and B8
- top-entry BT valves.

### **Market segments and applications**

GROVE valves meet the frequent-cycling, high- and low-temperature, corrosive demands of gas processing applications with increased safety and operational efficiency.

- Onshore operations—separation, wastewater disposal, tank battery, recovery, SAGD, and oil sands applications
- Pipeline operations—transmission, emergency shutdown, pigging, and pump and compressor station applications
- Liquid tank storage—tank storage isolation, custody transfer, metering skids, and loading and unloading applications
- Offshore operations—production, separation, processing and compression, and storage, metering, and exporting
- Subsea operations—fluid control and isolation for manifolds, flowlines, and risers



*To ensure that GROVE valves are manufactured to the highest standards, Cameron employs a stringent quality assurance program that encompasses the entire operation—from order entry to final inspection and field service.*

# GROVE IST Integrated Seat Technology Ball Valves

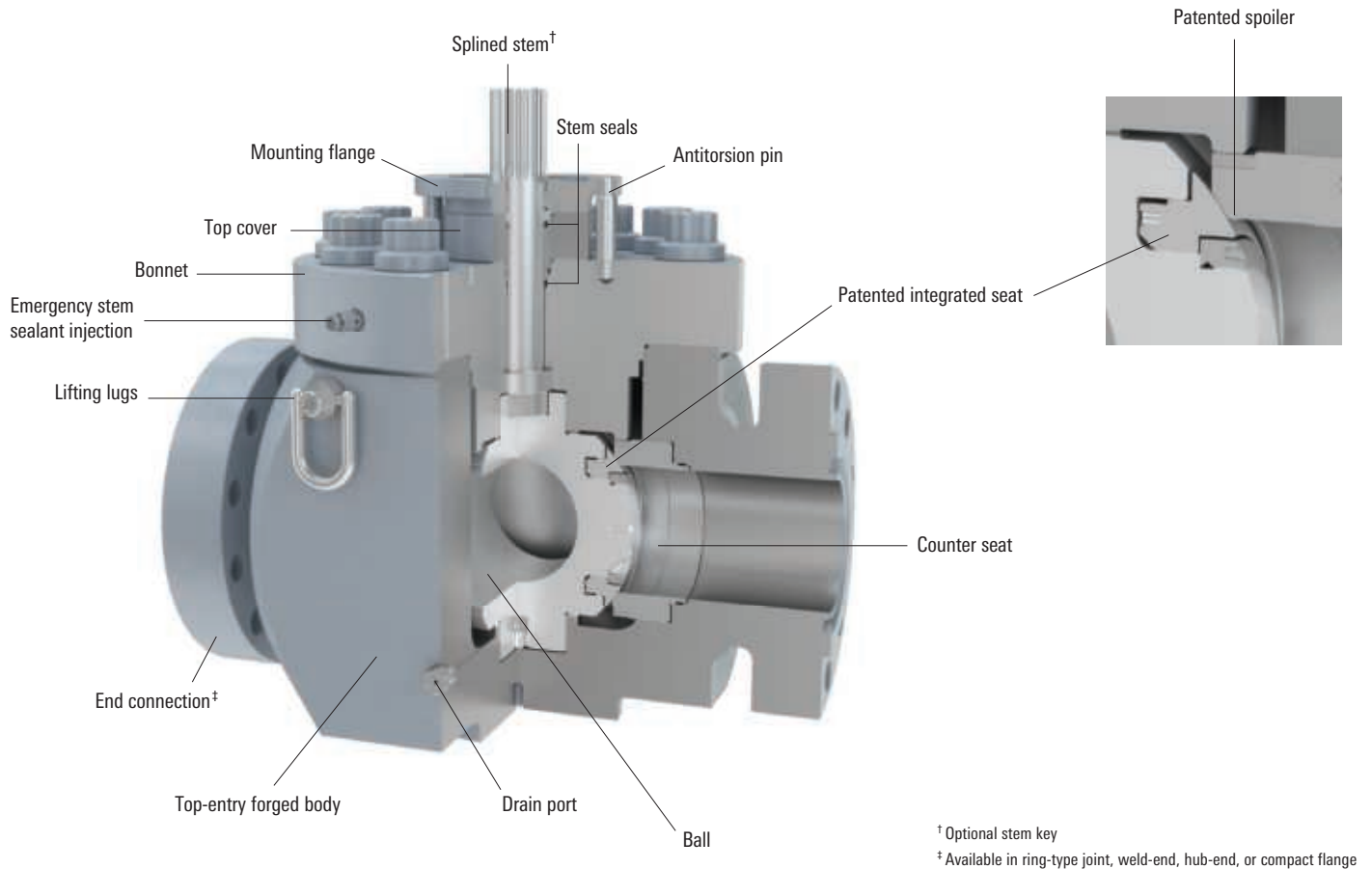

The GROVE IST integrated seat technology ball valve meets and exceeds customer needs in critical applications—longer life span, small and lightweight footprint, high efficiency, and lower total cost of ownership.

The next evolution in trunnion-mounted ball valve design, the GROVE IST ball valve features a patented seat design that decouples ball flex and deformation from sealing performance. When pressure is applied to the valve, its integrated seat is energized, generating a reliable seal independent of ball deflection. While the valve is open, the patented spoiler in the counter seat diverts fluid and debris away from critical sealing areas, further increasing reliability. The GROVE IST ball valve also features a top-entry design for streamlined, simplified inline maintenance that reduces overall downtime.

**Size**  
4 to 12 in

**Pressure class**  
ANSI 1500 to 2500

## Features

- Optimized valve and compact actuator assembly that overcomes ball flexing and deformation up to 10,000 psi [68.9 MPa]
- Patented flow-diversion spoiler to protect primary sealing elements
- Enhanced sealing capability compared with conventional metal-seated ball valves
- Optimized design using finite-element analysis (FEA) and computational fluid dynamics (CFD)
- Pressure-balanced design for quick closing
- Top-entry body configuration with simplified inline maintenance
- Rigorous testing beyond industry requirements

## Options

- Variety of automation options, from gear operators to pneumatic, hydraulic, or electric LEDEEN\* actuators

# B4 Valve

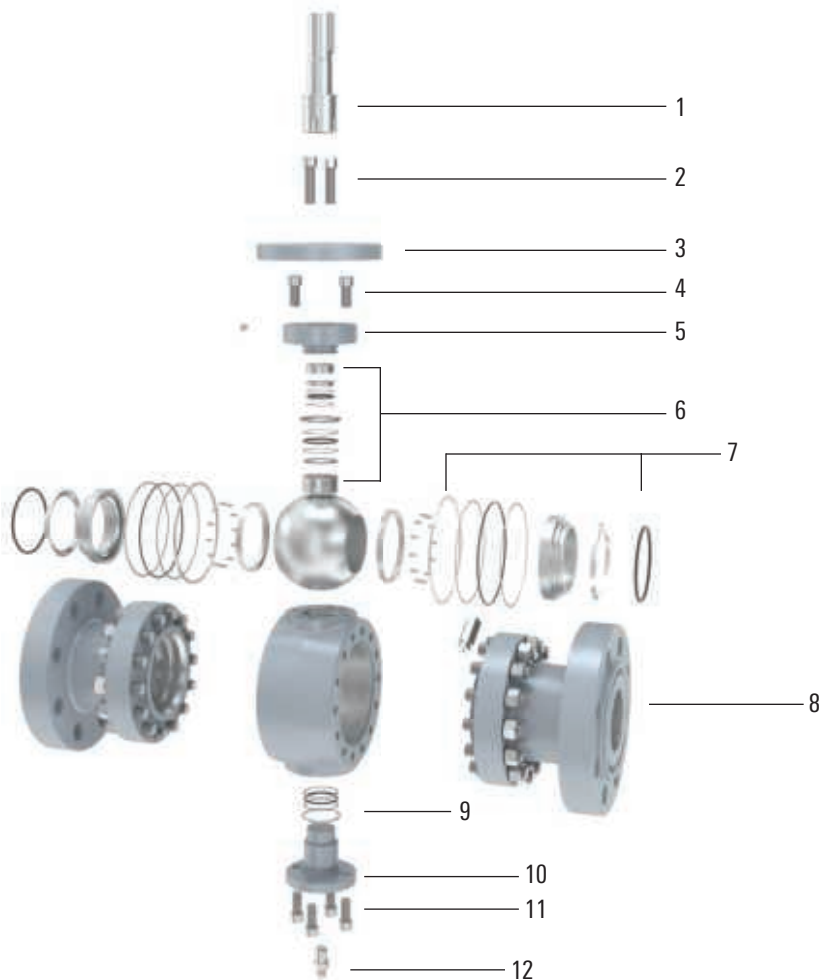

1	Stem
2	Adapter plate bolting
3	Adapter plate
4	Top cover bolting
5	Top cover
6	Stem and ball bearings, stem seals, and upper thrust washer
7	Seat assembly with seals
8	Closure
9	Lower trunnion seals and lower thrust washer
10	Lower trunnion
11	Lower trunnion bolting
12	Drain valve

## Valve construction

The B4 valve is constructed of forged components bolted together in a side-entry design. The standard designs are ideal for transmission and standard production operations. This design also allows for specialty configurations required in applications such as subsea installation and LNG plants.

### Features

- Double-barrier stem seals, the upper of which can be replaced with the valve in line, under pressure, and with the ball in the closed position
- Factory-positioned external stops
- Fire-safe graphite rings for protection against external leakage
- Metal-backed, self-lubricating PTFE sleeve bearing and thrust washers that reduce torque and extend service life
- Nickel plating for trim parts
- Plastic polymer insert for seat sealing
- Self-relieving seats qualified for ASME Classes 150 and 300
- Short coupled trunnions that reduce unit bearing loads and operating torque
- Stem that is separated from the ball, delivering an antiblowout design

### Options

- Antistatic device
- Double block-and-bleed capabilities
- Double-sealing barrier in both directions for ASME Classes 600, 900, and 1500; body relief valve for overpressure due to liquid thermal expansion
- Explosive decompression-resistant seal
- Metal-to-metal seats
- Various grades of PTFE for stem and seat sealing

### Size

1½ to 4 in

### Pressure class

ANSI 150 to 1500

# B5 Valve

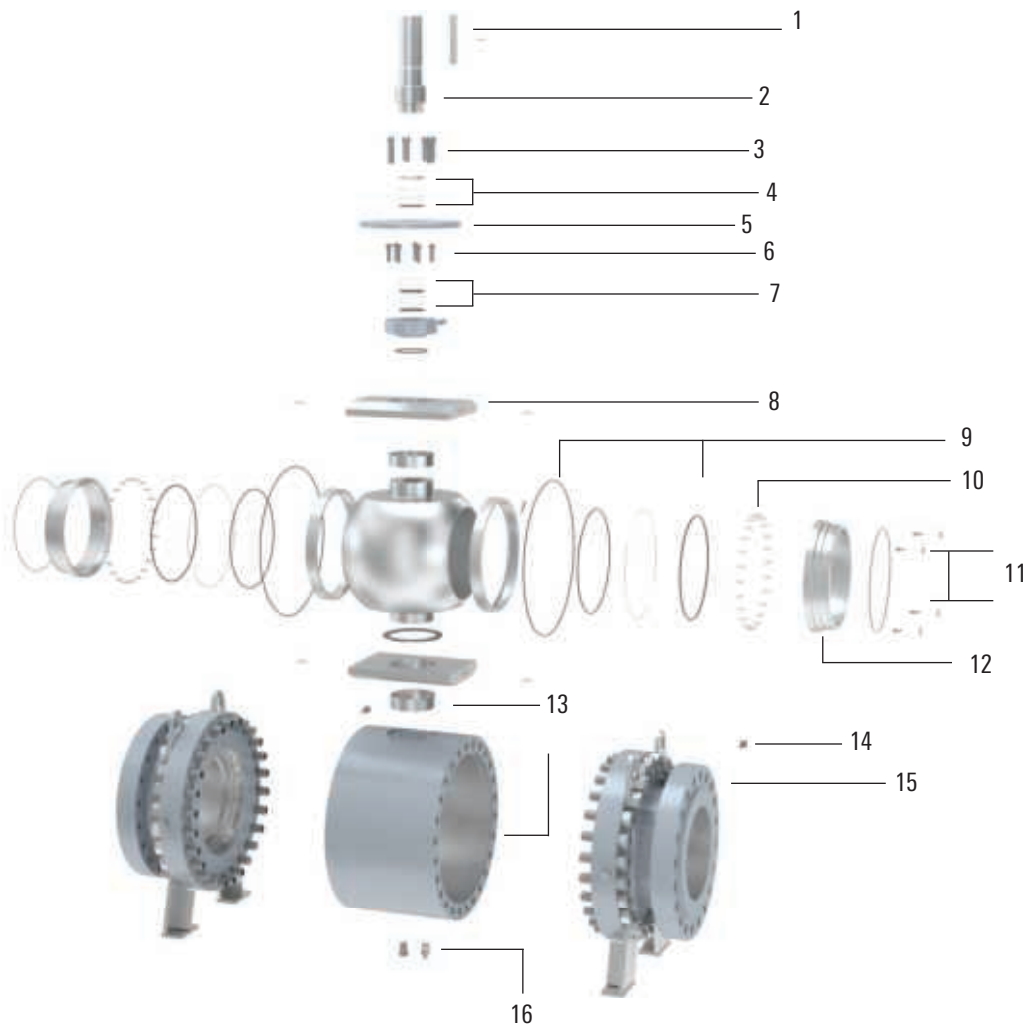

1	Stem key
2	Stem
3	Adapter plate bolting
4	Stem bearing and spacers
5	Adapter plate
6	Top cover bolting
7	Stem seals
8	Bearing retainer
9	Seat seals
10	Seat springs
11	Seat bolting
12	Seat ring
13	Bearing
14	Grease fitting
15	Closure
16	Drain valve

## Valve construction

The B5 valve is constructed of forged components bolted together in a side-entry design. The standard designs are ideal for transmission and standard production operations. This design also allows for specialty configurations required in applications such as subsea installation and LNG plants.

### Features

- Antistatic device
- Bearing blocks that absorb the pressure load on the ball
- Body relief valve for overpressure due to liquid thermal expansion
- Bolted construction that permits disassembly in the field for repairs
- Built-in sealant injection system for emergency seat seal
- Double-barrier stem seals
- Double-sealing barrier in both directions
- Integral stop in the adapter plate for a permanent reference to open and closed position
- Large-diameter, short coupled trunnions that reduce unit bearing loads and operating torque
- Metal-backed, self-lubricating PTFE sleeve bearing and thrust washers that reduce torque and extend service life
- Nickel plating for trim parts
- Primary metal-to-metal seal and secondary protected synthetic O-ring seal
- Stem that is separated from the ball, delivering an antiblowout design
- Trunnion-mounted ball for ease of operation at high pressure

### Options

- Double block-and-bleed capabilities
- Emergency grease fitting for stem
- Plastic polymer O-ring or insert for primary seat sealing
- Self-relieving seats
- Triple-barrier stem seals
- Various grades of PTFE for stem and seat sealing

### Size

6 to 60 in

### Pressure class

ANSI 150 to 1500

# B7 Valve

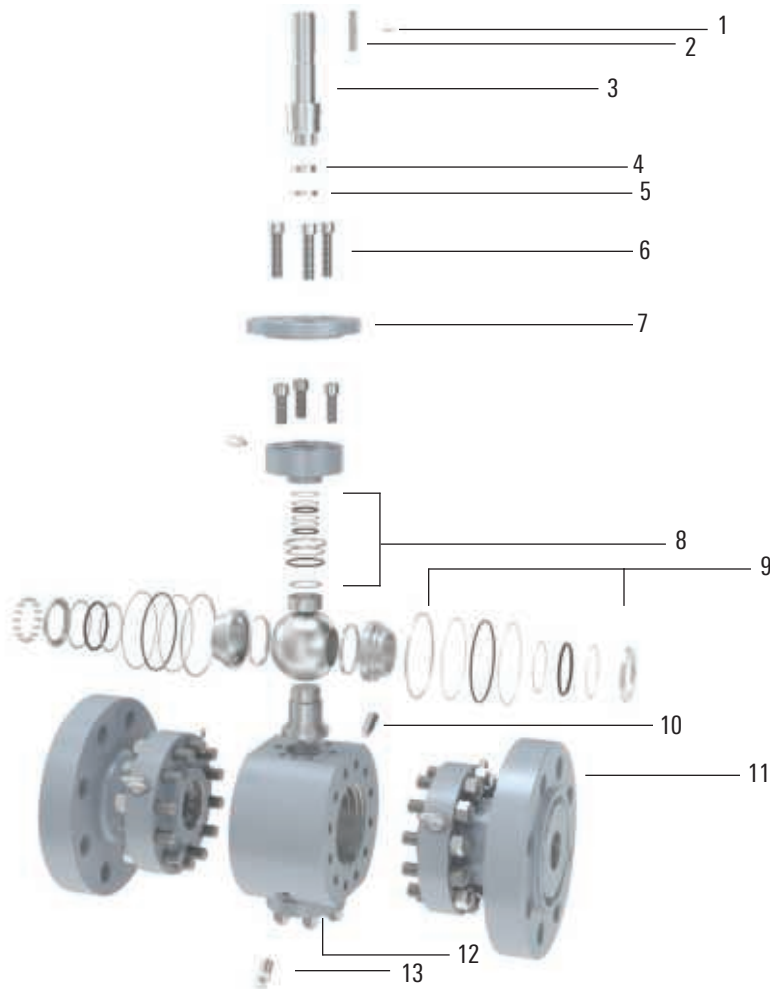

1	Stem key screw
2	Stem key
3	Stem
4	Stem bearing
5	Gland bushing
6	Adapter plate bolting
7	Adapter plate
8	Stem and ball bearings, stem seals, and upper thrust washer
9	Seat seals
10	Relief valve
11	Closure
12	Lower trunnion plate
13	Drain valve

## Valve construction

The B7 valve identifies the side-entry ball valve ASME Class 2500. Because of the high pressure and strong force involved, material selection is carried out by paying particular attention to the antiextrusion features of the gaskets and to the resistance of the ball and stem materials.

### Features

- Antistatic device
- Ball load on the bearing blocks
- Body relief valve for overpressure
- Emergency grease fitting for stem
- Factory-positioned external stops
- Fire-safe graphite rings
- Metal-backed, self-lubricating bearings and washers
- Nickel plating for trim parts
- Plastic polymer insert for seat sealing
- Sealant injection system for emergency seal
- Self-relieving seats
- Stem separated from the ball; antiblowout design
- Triple-barrier stem seals
- Trunnion-mounted ball

### Options

- PTFE, various grades of reinforced gaskets, and spring energizing for stem and seat sealing
- Metal-to-metal seats
- Double piston effect (DPE) double-barrier sealing in both directions
- Body relief valve for overpressure
- Double block-and-bleed capabilities

### Size

1½ to 20 in

### Pressure class

ANSI 2500

# B8 Valve

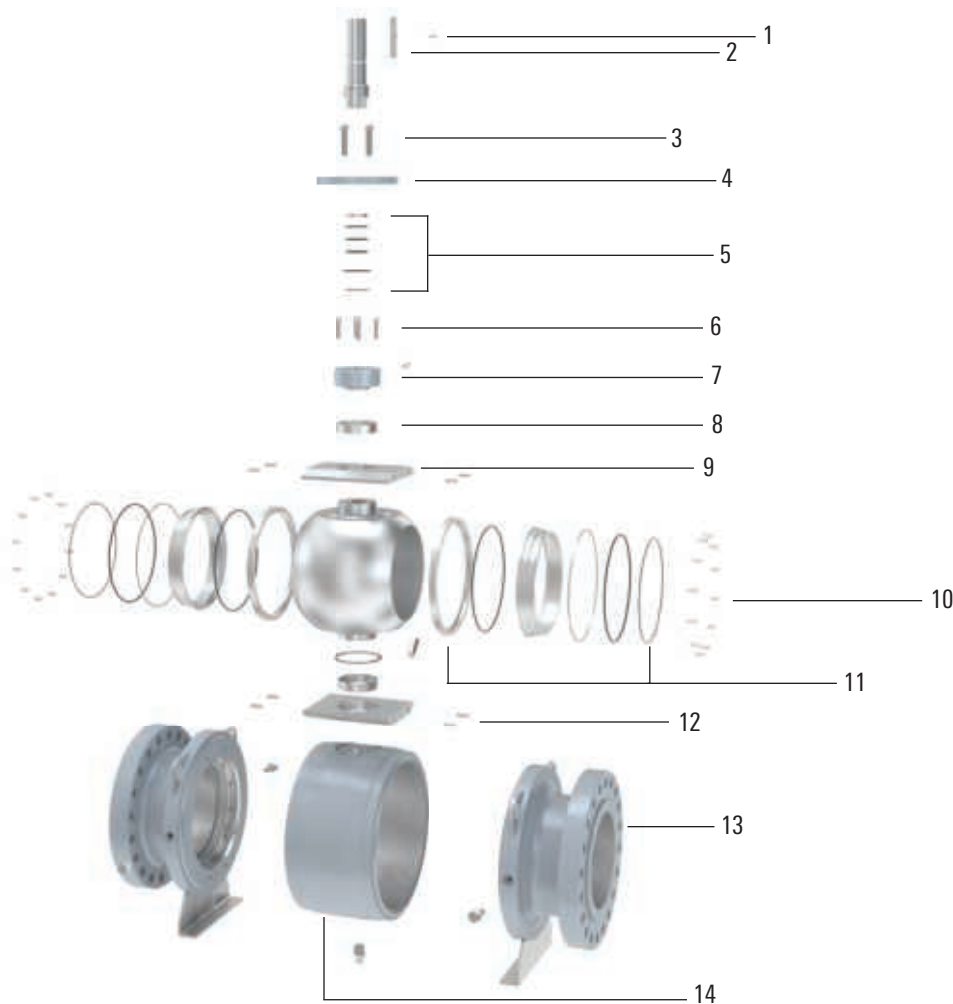

1	Stem key screw
2	Stem key
3	Adapter plate bolting
4	Adapter plate
5	Stem seals and gland bushing
6	Top cover bolting
7	Top cover
8	Ball bearing
9	Bearing retainer
10	Seat springs
11	Seat assembly with seals
12	Pins
13	Closure
14	Body

## Valve construction

The B8 valve is constructed of a forged components welded together in a side-entry design. The all-welded configuration is ideal for installations such as buried service.

### Features

- Antiblowout stem design
- Block-and-bleed and double block-and-bleed design
- Electroless nickel plating (ENP) on pressure-controlling parts and stem
- Factory-positioned external stops
- Forged body and all-welded construction
- Integral stop in the adapter plate for a permanent reference to open and closed positions
- Low-friction, metal-backed, self-lubricating PTFE sleeve bearings and thrust washers
- Stem and seat sealant injection system
- Stem that is separate from ball

- Triple-barrier stem seals

- Trunnion-mounted ball

### Options

- Antistatic device
- Cavity-relief valve for overpressure caused by liquid thermal expansion
- Fully welded bonnet
- Metal-to-metal seat sealing
- Self-relieving seat rings
- Soft seats (polymer inserts)
- Spring-energized gaskets made of PTFE with various grades of fillers for stem and seats (lip seals for DPE seats)

- Stainless or INCONEL® overlay in critical sealing areas

- Stem extensions

- Transition pieces

### Size

2 to 60 in

### Pressure class

ANSI 150 to 2500

# BT Valves

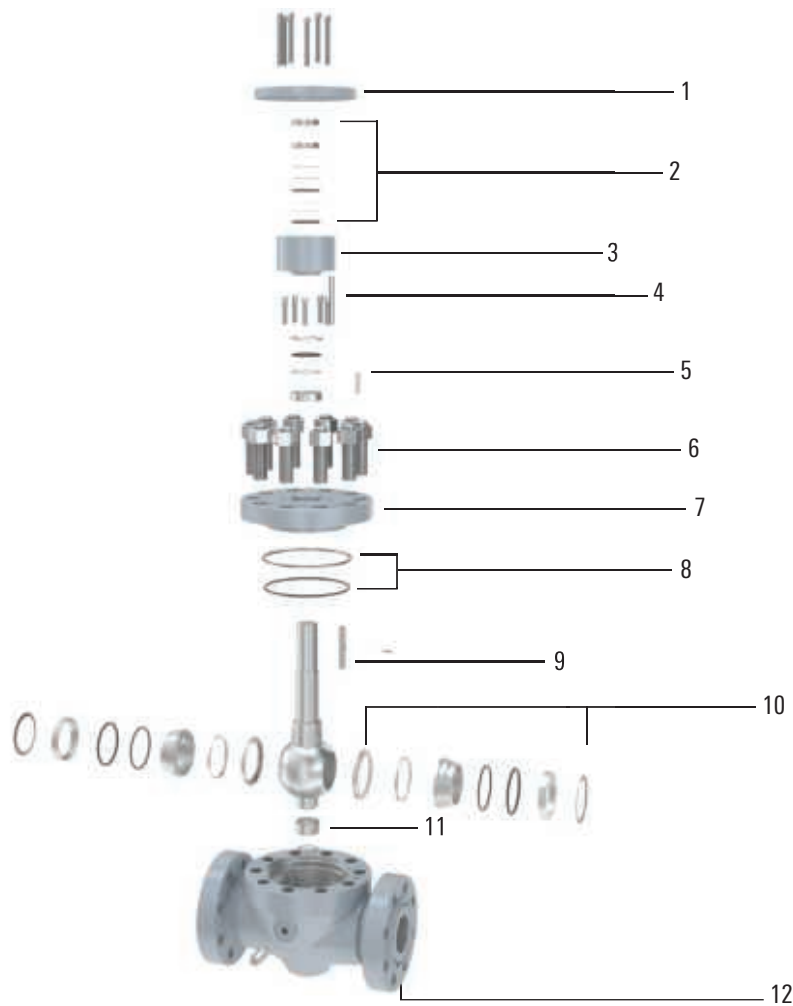

1	Adapter plate
2	Stem seals and gland bushing
3	Top cover
4	Top cover bolting
5	Pin
6	Bonnet bolting
7	Bonnet
8	Body and bonnet seals
9	Stem key
10	Seat assembly with seals
11	Ball bearing
12	Body

## Valve construction

The BT valve is a top-entry design composed of a cast body and other forged components. This design is ideal for applications in which scheduled service work can be done without having to remove the valve from the pipeline.

### Features

- Adapter plate with integral position indicator
- Antiblowout stem design
- API Spec 6FA fire-safe design
- Body thickness in accordance with ASME Standard B16.34
- DPE seats
- End flange dimensions in accordance with API Standard 6D
- Inline maintainability
- Low-friction, metal-backed, self-lubricating design
- Nickel plating on pressure-controlling parts and stem in function of the trim material

- PTFE sleeve bearing and thrust washers
- Standard design as per API Spec 6D
- Stem emergency grease fitting
- Triple-barrier stem seals
- Trunnion-mounted ball

### Options

- AISI 316 and INCONEL 625 overlay on all sealing and wetted areas
- Antistatic device
- Double block-and-bleed functionality
- Explosive-decompression-resistant seals
- Features for vertical pipe installation
- Lubricated seats

- Metal-to-metal seat sealing
- NACE MR0175/ISO 15156 qualification
- PTFE spring-energized lip seals for sealing
- Self-relieving seats and dual-seat design
- Special face-to-face and bore sizes
- Special flanges or end connections

### Size

1½ to 60 in

### Pressure class

ANSI 150 to 2500

# Actuation



A variety of automation options are available, from gear operators to pneumatic, hydraulic, or electric actuators. Coupling the GROVE IST ball valve with our compact LEDEEN actuator technology offers further opportunity to reduce space and weight.

Compact HS and CP actuator models in the LEDEEN actuator portfolio are some of the smallest actuators available on the market, saving valuable space on a production platform or FPSO vessel when installing automated valve packages within the piping system.

Two different torque mechanisms are used in the compact actuators, enabling the most appropriate mechanism to be used for maximum efficiency.

- For high-pressure hydraulic applications, a small helical spline mechanism is used with a small piston diameter to generate high torque outputs.
- For low-pressure pneumatic applications, the larger helical slot mechanism is combined with a larger piston diameter to generate an equivalent torque output.

## Cameron actuation portfolio

- Compact actuators and controls
- Direct gas actuator and controls
- Gas-over-oil actuator and controls
- Hydraulic actuators and controls
- Pneumatic actuators and controls
- Self-contained control systems
- Electric actuators
- Subsea actuators and controls

# Quality Management System (QMS)

Cameron runs a high-level quality control program to ensure all products are manufactured to the highest standards using the latest technology. The quality assurance program encompasses the entire operation, from order entry to final inspection and field service.

All valves are designed in accordance with the most stringent industry procedures and standards and are built according to the European Directives Pressure Equipment Directive (PED) and ATEX upon request.

Cameron is an authorized licensee to use the API monogram for specifications 6D and 6A. Our QMS program conforms to

- API Spec 6A
- API Spec 6D (license 001)
- API Spec 6DSS (license 003)
- API Spec Q1
- ATEX Directive 94/9/EC
- Canadian registration number
- EN 729-2—welding quality
- ISO 14001
- ISO 15848-1—fugitive emissions
- ISO 3834—quality of fusion welding of metallic materials
- ISO 9001
- OHSAS 18001—health and safety
- PED Directive 97/23/EC
- SIL to IEC 61508—functional safety of electrical, electronic, and programmable electronic safety-related systems
- Technical Regulation Custom Union
- Major customer approvals

## Inspection

Inspection is done per the quality system requirements based on ISO 9001:2015 and API Spec Q1.

Cameron verifies all processes from material receipt to final customer inspection, including the liaison with third-party inspection and certifying authorities.

All products can be supplied with certified test reports, which include pressure testing, nondestructive testing, and chemical and physical analysis, along with any other specified special test requirements.

The material certification of the valve parts can be furnished in accordance with DIN 50049 EN 10204.



*Because Cameron is the OEM, we are best equipped to quickly and efficiently deliver total support and services to GROVE valves.*



# Qualification and Testing

## High-pressure gas testing

Customer specifications may require more detailed testing in addition to conventional hydrostatic testing. Cameron is fully equipped to carry out enhanced gas testing at ambient, low, or high temperatures using in-house, specially equipped, state-of-the-art test bunkers. External leakage rates, if any, are detected by means of a mass spectrometer. Leakage through the seats, if any, is measured by means of calibrated flowmeters. For low- or high-temperature service, gas testing can be performed to customer-specified critical conditions.

## Inspection and testing

All products are supplied with certified test reports, which include hydrostatic pressure test reports as well as chemical and physical analyses of pressure-containing components. Nondestructive and other specified examinations are included in the final certification if requested. All valves are hydrostatically pressure tested in accordance with ISO 14313/API Spec 6D. A complete range of equipment and instrumentation is available to perform both standard and special test requirements.

## Research and development laboratory

GROVE valves are designed in accordance with the applicable or requested codes and are subjected to full in-house qualification testing. Our in-house testing facilities, with the participation of the major oil and gas companies' R&D programs, enable Cameron to supply high-quality products. Testing

for hydraulic and gas sealing, functionality, cycling, and torque are all carried out on prototype valves. These test procedures ensure that the design safety factors, maximum allowable leakage rates, and expected valve service life are achieved.

## Structural verification

Cameron's engineering department operates an advanced 3D computer-aided design system and conducts finite element analysis to simulate various load conditions to determine a component's suitability for the intended service.

## Fire-safe tests and certifications

Cameron conducts in-house fire-safe testing, and its GROVE valves are certified in compliance with API Specs 6FA and BS 6755 Part 2 fire-safe standards. A complete reference list of qualified and certified valves is available upon request.

## Cycle testing under flow conditions

Through its in-house flow facility, Cameron verifies the behavior of valves subjected to cycle testing under dynamic flow conditions with the presence of abrasive particles. This test loop can test valves up to 6-in nominal bore with a maximum service pressure of 2,900 psi [200 bar]. The main test parameters are entered into and recorded in a PC for future design reference.



*All GROVE valves are subjected to comprehensive in-house qualification testing to ensure that the design specifications are achieved in the field.*

## Services for Valves and Actuation

### Global network and local support

Cameron is well positioned to quickly and efficiently deliver total support with unmatched OEM expertise. Our highly skilled engineers and technicians are available 24/7/365 to respond to customer queries, troubleshoot problems, and offer reliable solutions.

### Easily accessible parts and spare valves

- OEM spare valves, actuators, and parts (including non-Cameron brands)
- Handling, storage, packaging, and delivery
- Dedicated stocking program

### Comprehensive services portfolio

- Parts and spare valves
- Repair
- Field services
- Preventive maintenance
- Equipment testing and diagnostics
- Remanufacturing
- Asset preservation
- Customer property management
- Training and recertification services
- Warranty

### Customized total valve care programs

We offer customized asset management plans that optimize uptime, availability, and service.

- Engineering consultancy
- Site management
- Flange management
- Startup and commissioning
- Spare parts and asset management
- Operational support

# GROVE Valves



[products.slb.com/grove](https://products.slb.com/grove)

\*Mark of Schlumberger  
Other company, product, and service names  
are the properties of their respective owners.  
Copyright © 2018 Schlumberger. All rights reserved. 18-VL-387371

 **CAMERON**  
A Schlumberger Company