

# Nutron 320F3/B3

Forged floating ball valves



# Contents

## Nutron 320F3 and 320B3 Forged Floating Ball Valves

- Features and Benefits . . . . . 3
- Specifications . . . . . 5
- How to Order 320F3 . . . . . 6
- How to Order 320B3 . . . . . 7
- Materials List . . . . . 8
- Actuator Trim Codes . . . . . 8
- Dimensional Data—1/2-in Full Port Through 8-in × 6-in Reduced Port 320F3 . . . . . 9
- Dimensions 320F3 . . . . . 10
- Dimensional Data—1/2-in Full Port Through 4-in × 3-in Reduced Port 320B3 . . . . . 12
- Dimensions 320B3 . . . . . 13
- Torque Estimation and MAST . . . . . 15
- Weights 320F3 . . . . . 16
- Weights 320B3 . . . . . 17

# Features and Benefits

The handle can be correctly installed only in alignment with the ball port. The valve is open when the handle is aligned with piping and is closed when the handle is perpendicular to piping.

## ASME Classes 600 through 2500

1/2-in full port through 8-in reduce port

NACE MR0175/ISO 15156

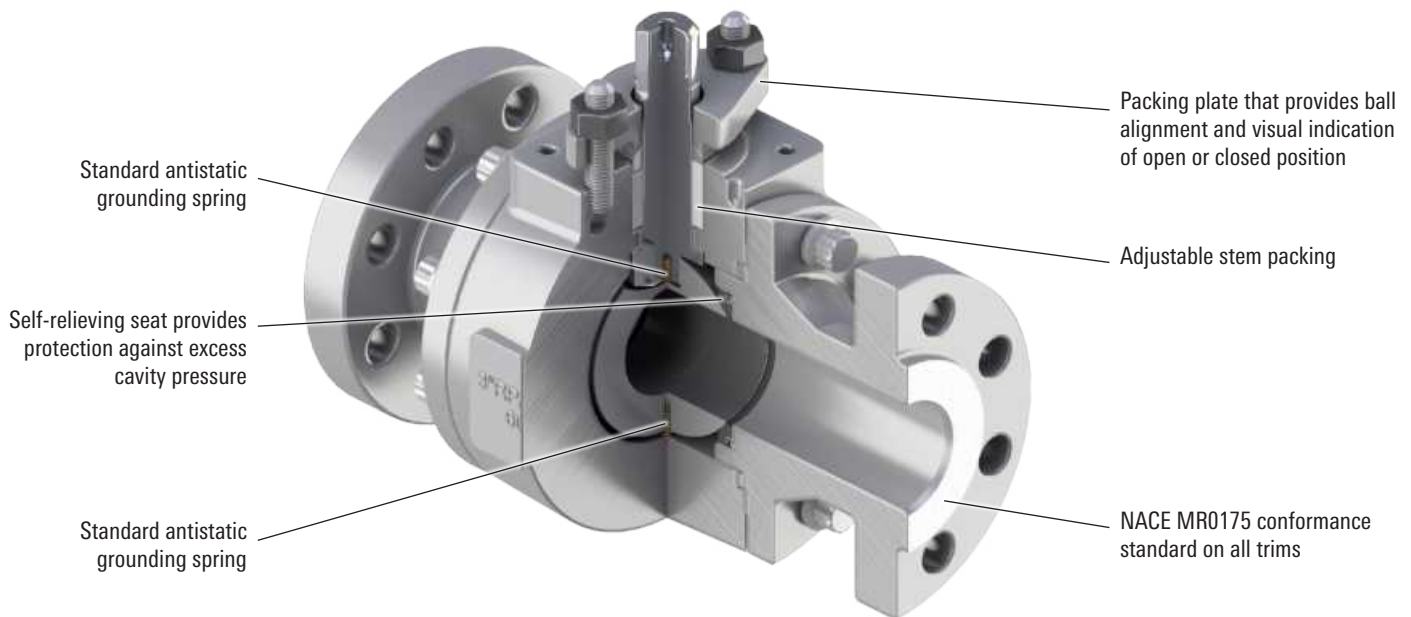

Nutron 320F3/B3\* forged ball valves satisfy a wide range of applications. Available in a variety of standard and optional materials, the valves are engineered for heavy-duty, maintenance-free performance and serve a variety of applications in virtually any industry.

### Low-temperature service

Standard trims accommodate temperatures to  $-20$  degF [ $-29$  degC], and temperature trims are available to  $-50$  degF [ $-46$  degC].

### Maintenance-free performance

Under most conditions, the Nutron 320F3/B3 ball valve will provide years of trouble-free service with no maintenance required. In some severe applications, such as handling extremely abrasive slurries at high temperature, it may be necessary to replace the seats occasionally. Seat and seal kits are available, and replacement can be done easily with ordinary tools.

### Sour oil and gas service

Nutron valves have served for years in gathering lines, manifolds, and field processing units in sour oil and gas fields. All trim combinations conform with NACE MR0175/ISO 15156.

# Features and Benefits

## Self-relieving seats

A patent-pending seat design provides automatic cavity relief without requiring a vented ball or external relief valve. API Spec 6D monogram is available upon request.

## Actuation friendly

A variety of actuator types, including pneumatic, hydraulic, diaphragm, vane, electromechanical, and electrohydraulic, can be easily installed.

## Fire tested for safety

All Nutron 320F3/B3 ball valves are qualified under API Standard 607 7th Ed. The seat and locked-in stem design contributes to its fire-tested characteristics. Should the soft seats be destroyed by fire, the ball floats downstream, providing a tight metal-to-metal seal against the lip of the seat pocket. If the tailpiece seals are destroyed, the metal-to-metal tailpiece-to-body connection retards external leakage.

## Adjustable, replaceable packing

The inline valve stem packing options consist of PTFE and graphite. The packing is field adjustable and virtually never requires lubrication.

## Fugitive emissions

Nutron 320F3/B3 ball valves can be supplied and certified to meet the requirements of fugitive emissions (FE) as regulated by ISO and API.

## Positively retained stem

The stem is positively retained and cannot be removed with the valve in service.

## Tight-sealing floating ball design

The ground, polished ball is free to float and mates perfectly with the conical seats for a positive, leak-proof seal. Self-cleaning and self-adjusting, the ball also is pressure activated—the higher the line pressure, the tighter the seal.

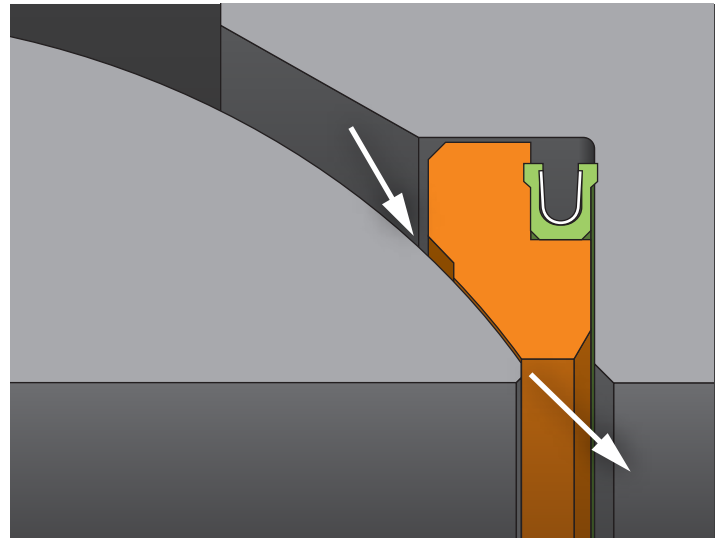

*Seat that relieves excess cavity pressure to the upstream side of the valve.*

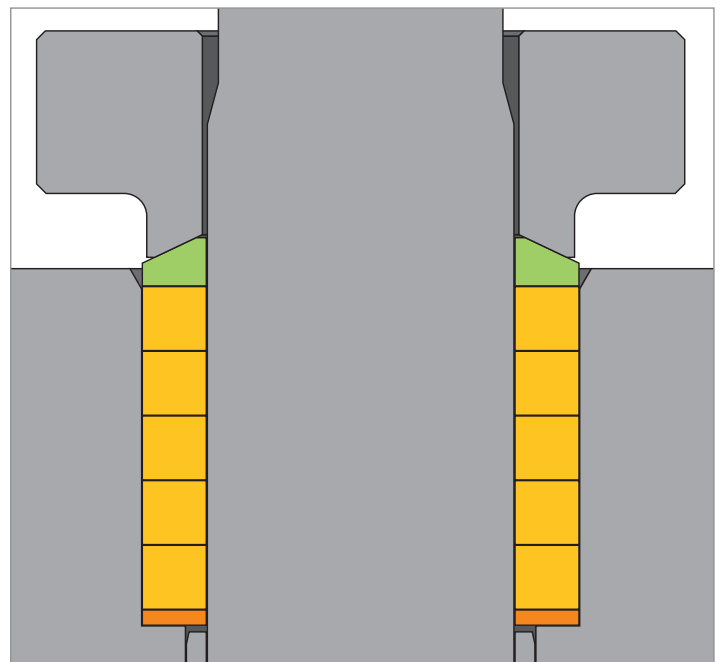

*Fugitive-emissions packing arrangement.*

# Specifications

## ASME Classes 600 through 2500

### Operating temperatures

- From -50 to 500 degF [-46 to 260 degC]

### Standard material

- Body
  - Carbon steel and stainless steel
- Ball and stem
  - Stainless steel
  - Optional materials available upon request

### Industry compliance

- American Society of Mechanical Engineers (ASME) Standards B16.5 and B16.34
- Manufacturers Standardization Society Specifications MSS SP-25, 55, and 72
- API Spec 607 7th Ed. fire-test specification
- Canadian Registration Number (CRN)
- API Spec 608
- NACE MR0175
- ANSI Standard B16.34
- API Spec 6D upon request
- ISO or API fugitive emissions upon request
- European Pressure Equipment Directive (PED/CE)

### Bill of Materials

Part No.	Quantity	Description
101	1	Body
102	2	Tailpiece
152	— <sup>†</sup>	Body bolt
190	2	Spiral-wound (SW) gasket, body to tail
211	1	Ball
222	2	Seat
223	2	Seat lip seal
241	1	Stem
261	1	Packing set (PTFE or graphite)
301	2	Stem thrust washer
302	1	Stem bearing
311	1	Packing compression ring
312	1	Packing plate
313	2	Packing stud
314	2	Packing nut
331 <sup>†</sup>	1	Lever
352 <sup>†</sup>	1	Ground spring, stem to ball
353	1	Grounding plunger, ball to body

<sup>†</sup>Quantities depend on size and pressure class.

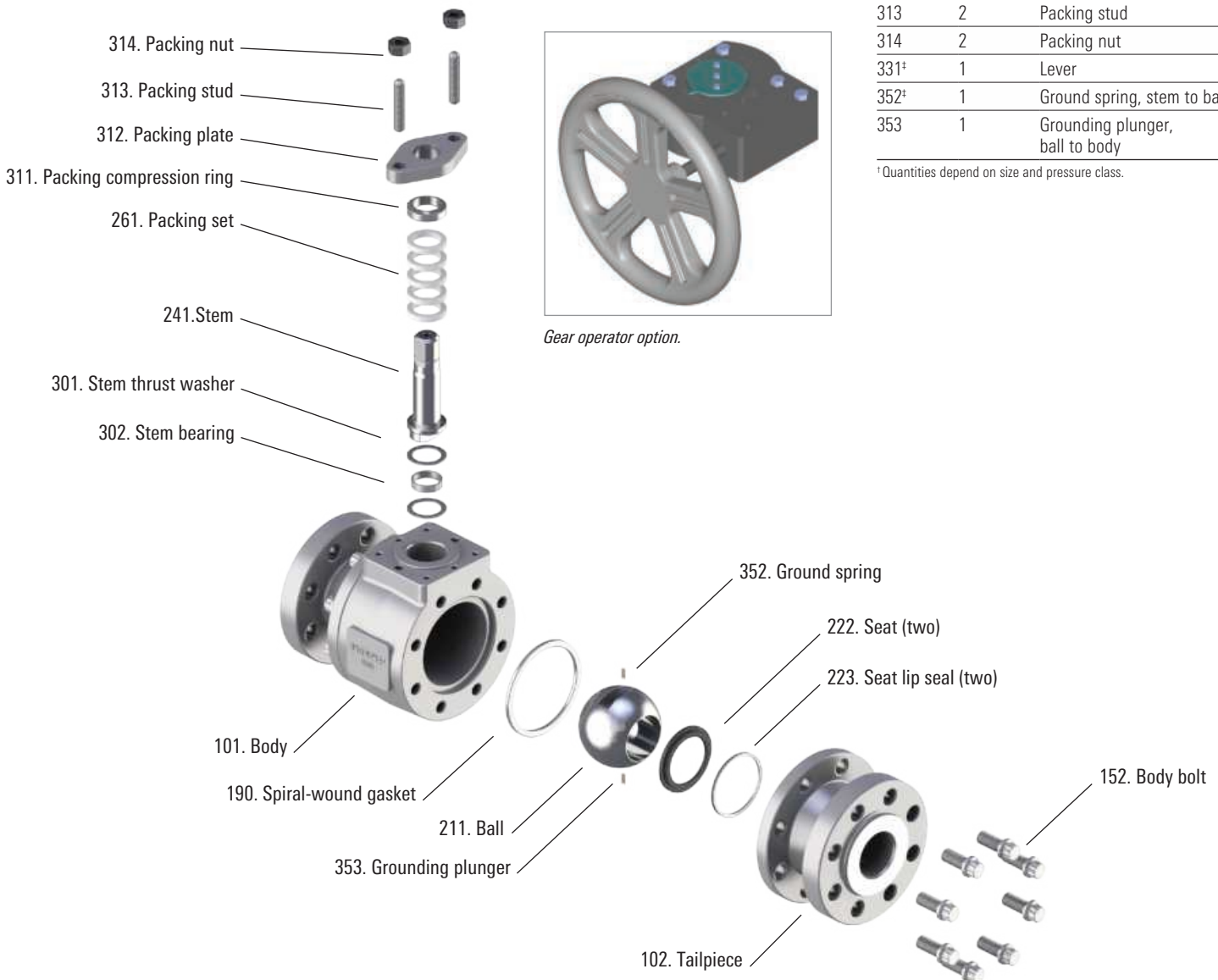

# How to Order 320F3

## 320F3 Forged Assembly Parts Number Sorting Code (three-piece forged)

### Example

**2424764 4 1 2 1 1 2 3**

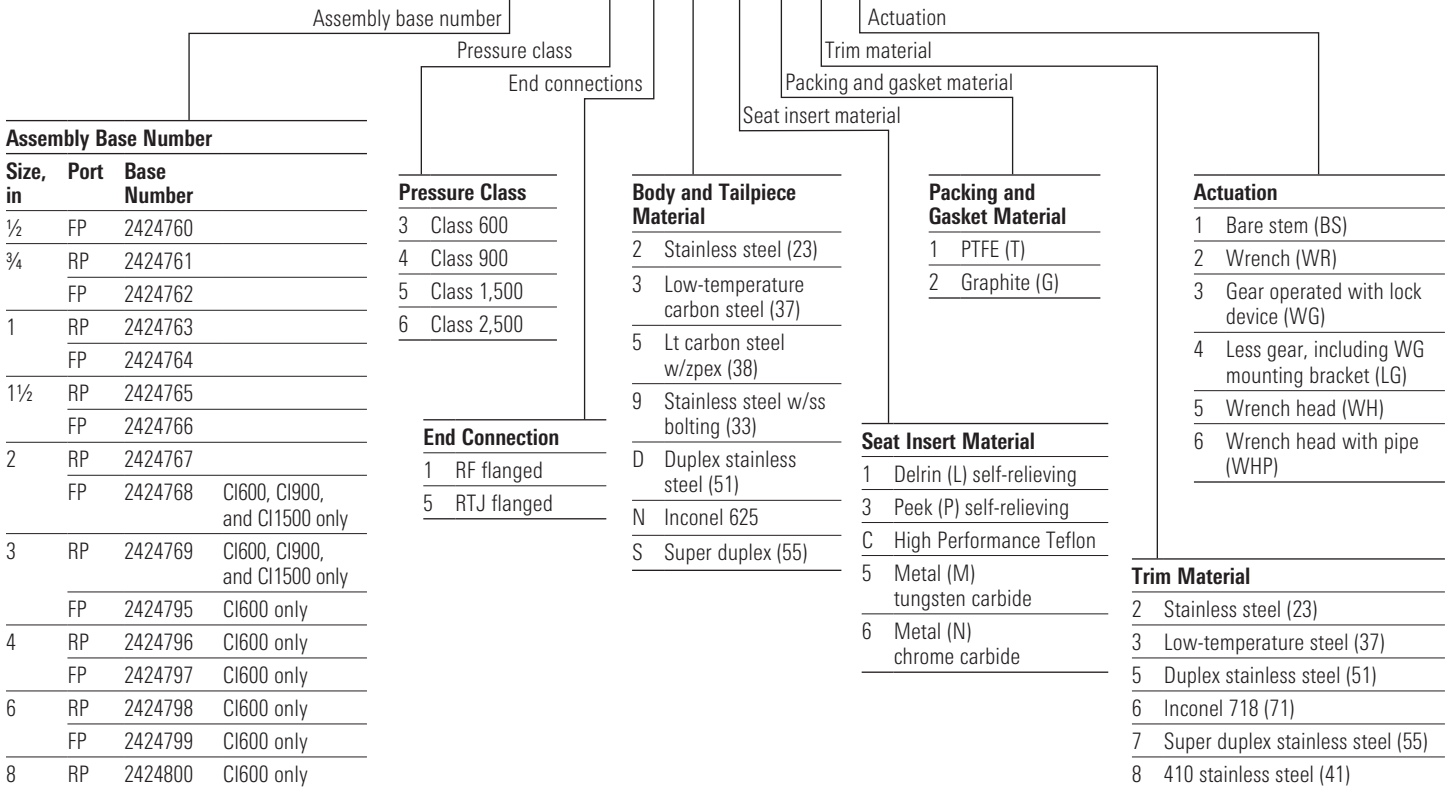

## Trim Codes

### Example

**2 320F3 600 RF × RF 37 P G F 23 LG**

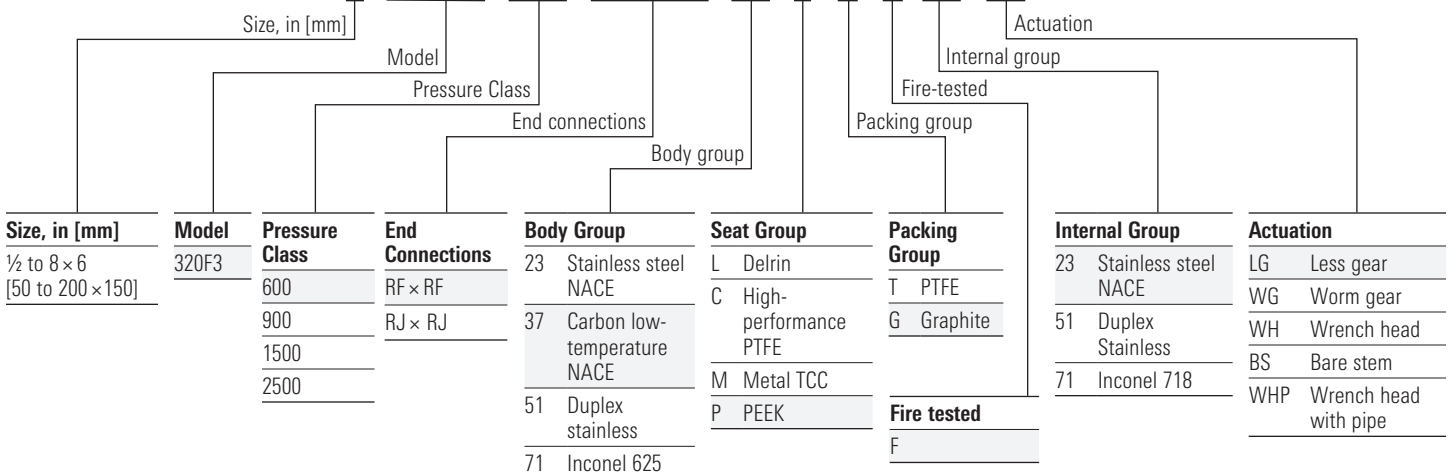

Note: Delrin and High Performance Teflon seat options - CI600 only.

# How to Order 320B3

## 320B3 Forged Assembly Parts Number Sorting Code (three-piece forged)

### Example

**2464774 4 1 2 1 1 2 3**

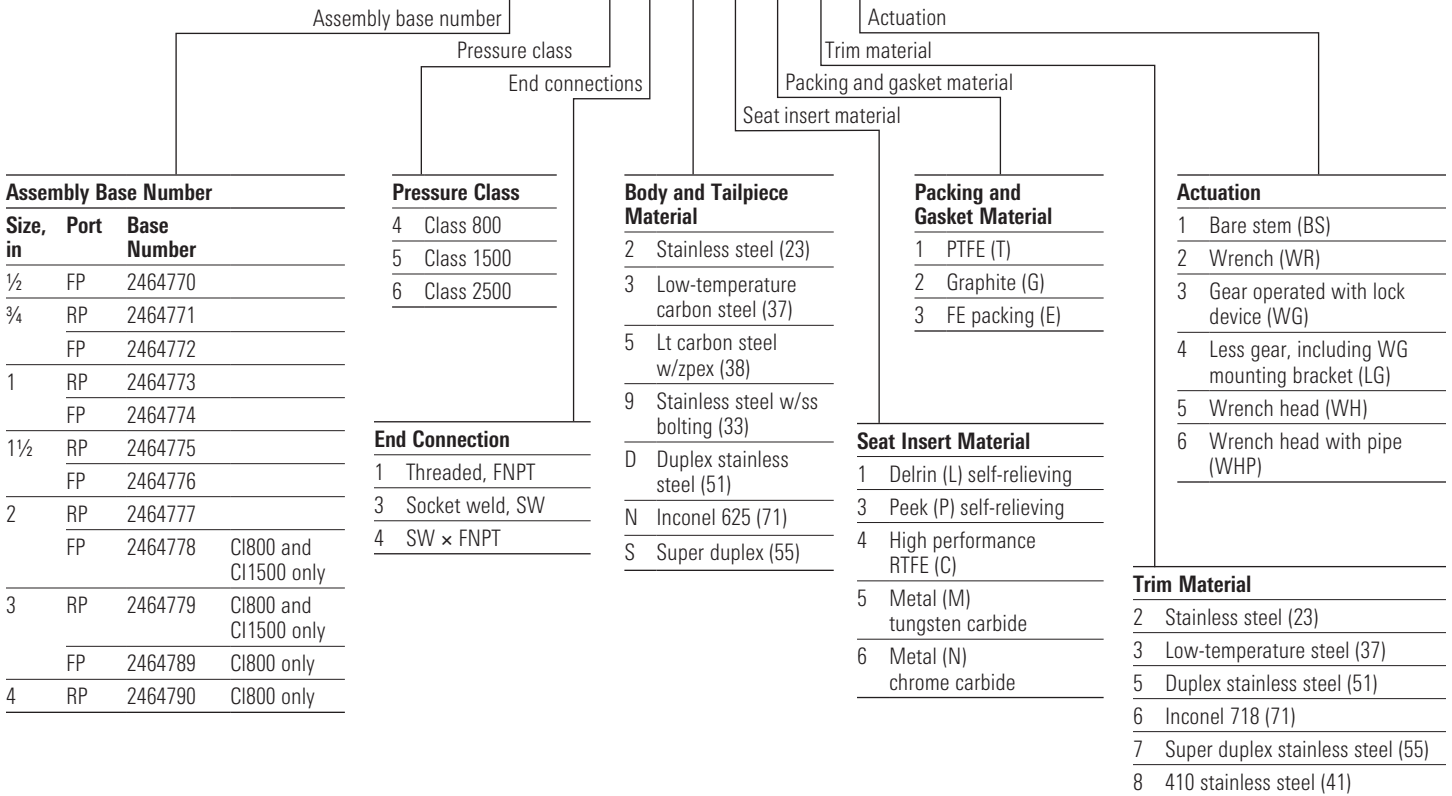

# Trim Codes

### Example

**2 320B3 800 NPT x NPT 37 P G F 23 LG**

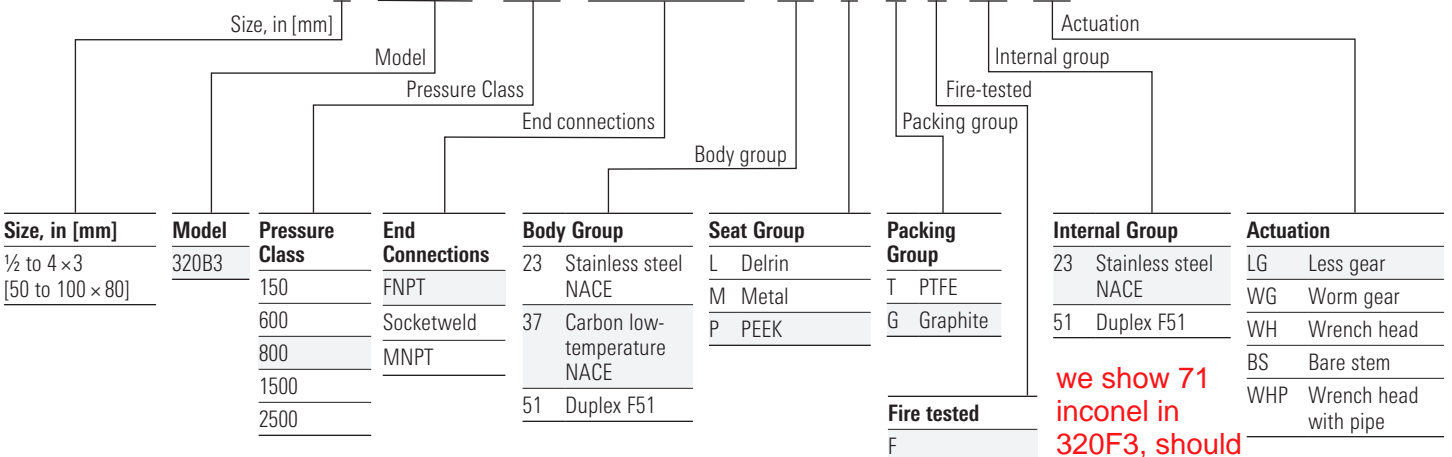

# Materials List

## Body Group Trim Number

Part	Carbon Steel Low Temperature with Coating (NACE) 37	Stainless Steel (NACE) 23	Carbon Steel Low Temperature with Coating (NACE) 38
Body	A350 - LF2 low-temperature	A182 Grade 316	A350 - LF2 low temperature, ZPEX® coating
Tailpiece	A350 - LF2 low-temperature	A182 Grade 316	A350 - LF2 low temperature, ZPEX® coating
Bonnet cap	Low alloy CS zinc plated	Low alloy CS zinc plated	Low alloy CS zinc plated
Cap screws	A320 Grade L7M zinc plated	A320 Grade L7M zinc plated	A320 Grade L7M zinc plated†
Packing studs	A320 Grade L7M zinc plated	A320 Grade L7M zinc plated	A320 Grade L7M zinc plated
Packing nuts	A194 Grade 7M zinc plated	A194 Grade 7M zinc plated	A194 Grade 7M zinc plated

NACE indicates compliance with NACE MR0175/ISO 15156.

† ZPEX coating on studs and nuts available on request.

## Internal Group Trim Number

Ball	—†	A351 CF8M or 316 SS	—
Stem	—†	316 stainless steel (SS)	—
Ground spring	—†	INCONEL	—
Compression ring	—†	316 SS	—
Thrust washer	—†	SS and TFE	—

† 320F3/B3 model requires 23 stainless internal group.

## Seal Group Trim Code

Part	LTF	TTF	CGF	PGF
Temperature limits	–20 to 220 degF [–29 to 104 degC]	–50 to 300 degF [–46 to 149 degC]	–50 to 500 degF [–46 to 260 degC]	–50 to 500 degF [–46 to 260 degC]
Seat	Delrin® material	Filled PTFE	High-performance PTFE	PEEK
Packing	PTFE	PTFE	Graphite	Graphite
Body seal	Spiral-wound gasket Grafoil® and SS	Spiral-wound gasket Grafoil and SS	Spiral-wound gasket Grafoil and SS	Spiral-wound gasket Grafoil and SS

# Actuator Trim Codes

## Actuator Codes

Part (Body)	Worm Gear—For All Body Material Codes
Mounting bracket	Carbon steel
Bolting	Carbon steel
Set screw	Carbon steel
Stem adapter	Carbon steel
Actuator	As selected
Handwheel	Carbon steel

## Actuator Codes (Wrenches)

Part (Body)	Wrench—For All Body Material Codes
Wrench head	Carbon steel
Wrench handle	Carbon steel
Wrench handle pin	Carbon steel
Capscrew	Alloy steel
Stop plate	Carbon steel

# Dimensional Data— $\frac{1}{2}$ -in Full Port Through 8-in $\times$ 6-in Reduced Port 320F3

$\frac{1}{2}$ -in full port through 8-in  $\times$  6-in reduced port ASME Classes 600 through 2500

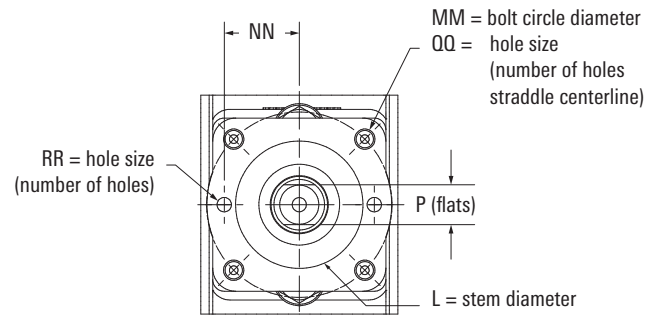
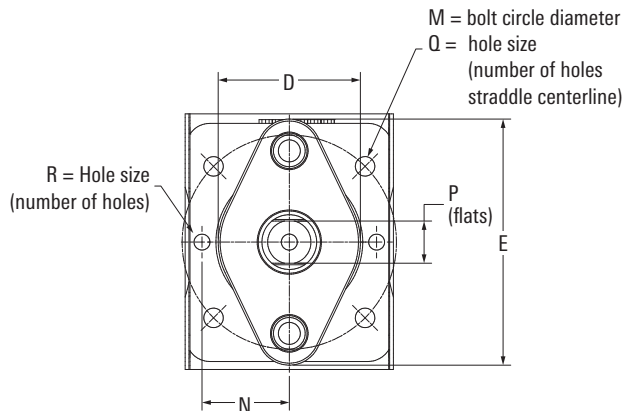

1.5-in 2500 above with bracket.

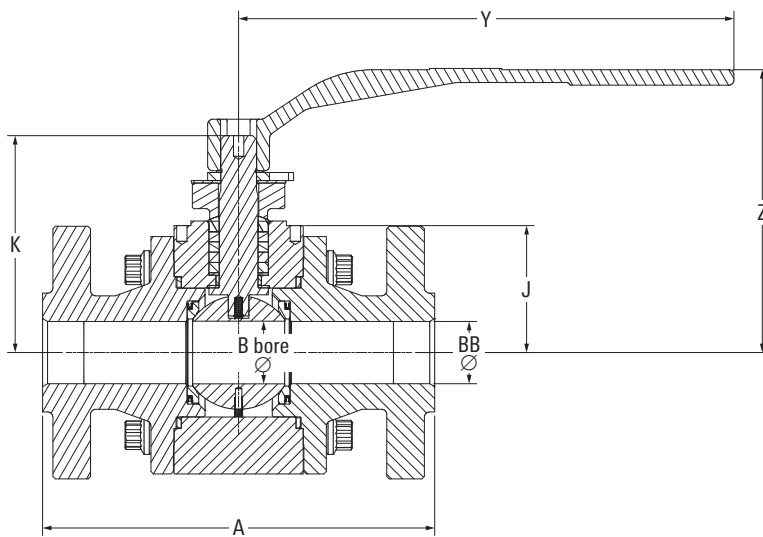

Valve with wrench (lever).

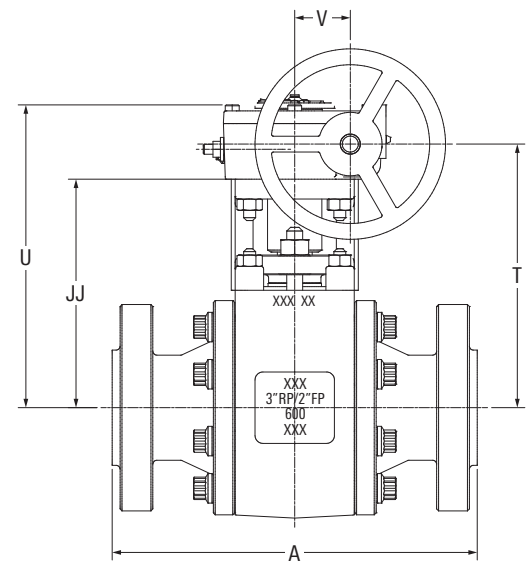

Valve with gear.

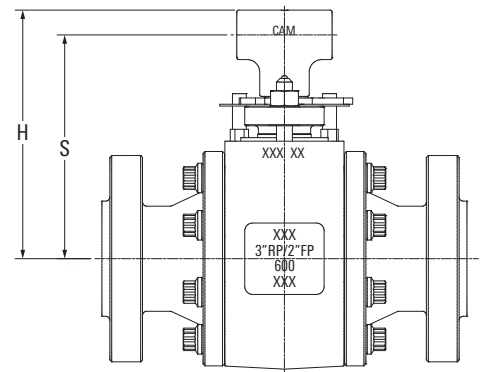
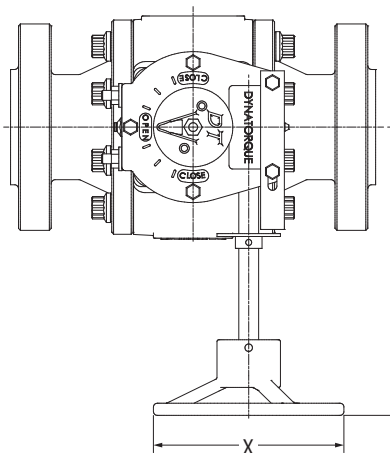
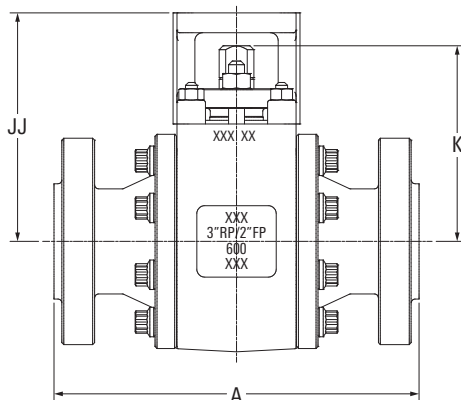

Valve with wrench hand.

# Dimensions 320F3

## NUTRON 320F3 Valve Class 600 Dimensions

Size, in [mm]	A		B	BB	D	E	J	JJ	K	ØL	ØM	MM	N	NN	P	ØQ	ØQQ	ØR	ØRR	S	T	U	V	W	ØX	Y	Z	
	RF	RJ																										
½ [13]	6.5 [165.1]	6.5 [165.1]	0.51 [13]	0.51 [13]	1.12 [28.4]	2.35 [59.7]	1.51 [38.4]	—	2.66 [67.6]	0.47 [11.9]	1.88 [47.6]	—	0.69 [17.5]	—	0.35 [8.9]	10-24 unc (4) 0.38 dp	—	0.13-(2) 0.19 dp	—	—	—	—	—	—	—	—	6 [152]	3.53 [89.7]
¾ × ½ [19 × 13]	7.5 [190.5]	7.5 [190.5]	0.51 [13]	0.76 [19.3]	1.12 [28.4]	2.35 [59.7]	1.51 [38.4]	—	2.66 [67.6]	0.47 [11.9]	1.88 [47.6]	—	0.69 [17.5]	—	0.35 [8.9]	10-24 unc (4) 0.38 dp	—	0.13-(2) 0.19 dp	—	—	—	—	—	—	—	—	6 [152]	3.53 [89.7]
¾ × ¾ [19 × 19]	7.5 [190.5]	7.5 [190.5]	0.76 [19.3]	0.76 [19.3]	1.25 [31.8]	2.66 [67.6]	1.8 [45.7]	—	3.34 [84.8]	0.55 [13.9]	2.13 [54.1]	—	0.81 [20.6]	—	0.43 [10.9]	0.25-20 unc (4) 0.44 dp	—	0.19-(2) 0.31 dp	—	—	—	—	—	—	—	—	8 [203]	4.45 [113]
1 × ¾ [25 × 19]	8.5 [215.9]	8.5 [215.9]	0.76 [19.3]	1.01 [25.7]	1.25 [31.8]	2.66 [67.6]	1.8 [45.7]	—	3.34 [84.8]	0.55 [13.9]	2.13 [54.1]	—	0.81 [20.6]	—	0.43 [10.9]	0.25-20 unc (4) 0.44 dp	—	0.19-(2) 0.31 dp	—	—	—	—	—	—	—	—	8 [203]	4.45 [113]
1 [25]	8.5 [215.9]	8.5 [215.9]	1.01 [25.7]	1.01 [25.7]	1.76 [44.7]	3.37 [85.6]	2.39 [60.7]	—	4.1 [104.1]	0.71 [17.9]	2.76 [70.1]	—	1.21 [20.6]	—	0.55 [13.9]	0.25-20 unc (4) 0.44 dp	—	0.19-(2) 0.31 dp	—	—	—	—	—	—	—	—	10 [254]	5.48 [139]
1½ [38]	9.5 [241.3]	9.5 [241.3]	1.51 [38.4]	1.51 [38.4]	2.24 [56.9]	3.88 [98.6]	3.08 [78.1]	—	5.26 [133.6]	0.86 [21.9]	3.38 [85.9]	—	1.38 [30.7]	—	0.67 [16.9]	0.38-16 unc (4) 0.63 dp	—	0.25-(2) 0.38 dp	—	—	—	—	—	—	—	—	12 [305]	6.85 [174]
2 × 1½ [50 × 38]	11.5 [292.4]	11.63 [295.4]	1.51 [38.4]	2.03 [51.6]	2.24 [56.9]	3.88 [98.6]	3.08 [78.1]	—	5.26 [133.6]	0.86 [21.9]	3.38 [85.9]	—	1.38 [34.9]	—	0.67 [16.9]	0.38-16 unc (4) 0.63 dp	—	0.25-(2) 0.38 dp	—	—	—	—	—	—	—	—	12 [305]	6.85 [174]
2 [50]	11.5 [292.1]	11.62 [295.1]	2.03 [51.6]	2.03 [51.6]	2.5 [63.5]	4.38 [111.3]	3.7 [94]	7.2 [182.9]	6.16 [156.5]	1.1 [27.9]	4.02 [102.1]	4.02 [102.1]	1.63 [41.3]	1.63 [41.3]	0.86 [21.9]	0.38-16 unc (4) 0.63 dp	0.44-(4) thru	0.31-(2) 0.53 dp	0.31-(2) 0.53 dp	8 [211]	9.54 [242]	1.75 [44]	9.08 [231]	6 [152]	16 [406]	7.56 [192]		
3 × 2 [80 × 50]	14 [355.6]	14.13 [358.9]	2.03 [51.6]	3.03 [77]	2.5 [63.5]	4.38 [111.3]	3.7 [94]	—	6.16 [156.5]	1.1 [27.9]	4.02 [102.1]	—	1.63 [41.3]	—	0.86 [21.9]	0.38-16 unc (4) 0.63 dp	—	0.31-(2) 0.38 dp	—	—	—	—	—	—	—	—	7.56 [185]	
3 [80]	14 [355.6]	14.12 [358.9]	3.03 [77]	3.03 [77]	3 [76.2]	5.38 [136.7]	5.14 [130.5]	9.76 [247.9]	8.57 [217.7]	1.41 [35.9]	4.92 [125]	4.92 [125]	1.94 [49.3]	1.94 [49.3]	1.06 [26.9]	0.5-13 unc (4) 0.75 dp	0.56-(4) thru	0.44-(2) 0.63 dp	0.44-(2) 0.63 dp	11 [283]	12.48 [317]	2.51 [64]	12.2 [310]	12 [305]	24 [610]	10.62 [270]		
4 × 3 [100 × 80]	17 [431.8]	17.12 [434.8]	3.03 [77]	4.03 [102.4]	3 [76.2]	5.38 [136.7]	5.14 [130.5]	9.76 [247.9]	8.57 [217.7]	1.41 [35.9]	4.92 [125]	4.92 [125]	1.94 [49.3]	1.94 [49.3]	1.06 [26.9]	0.5-13 unc (4) 0.75 dp	0.56-(4) thru	0.44-(2) 0.63 dp	0.44-(2) 0.63 dp	11 [283]	12.48 [317]	2.51 [64]	12.2 [310]	12 [305]	24 [610]	10.62 [270]		
4 [100]	17 [432]	17.1 [435]	4.03 [102]	4.03 [102]	3.5 [88.9]	6.25 [159]	6.22 [158]	12.2 [310]	10.8 [275]	1.89 [48]	5.51 [140]	6.5 [165]	2.38 [60]	2.38 [60]	1.41 [36]	0.63-(4) 1 dp	0.81-(4) thru	0.63-(2) 0.75 dp	0.31-(2) 0.81 dp	12.1 [306]	13.7 [348]	15.5 [393]	3 [76.2]	11.6 [294]	14 [356]	—		
6 × 4 [150 × 100]	22 [555.6]	22.1 [558.9]	4.03 [102]	6 [152]	3.5 [88.9]	6.25 [159]	6.22 [158]	12.2 [310]	10.8 [275]	1.89 [48]	5.51 [140]	6.5 [165]	2.38 [60]	2.38 [60]	1.41 [36]	0.63-(4) 1 dp	0.81-(4) thru	0.63-(2) 0.75 dp	0.63-(2) 0.81 dp	12.1 [306]	13.7 [348]	15.5 [393]	3 [76.2]	11.6 [294]	14 [356]	—		
6 [150]	22 [559]	22.13 [562]	6 [152]	6 [152]	4.25 [108]	7.75 [197]	15.4 [392]	15.4 [392]	14.1 [358]	2.36 [60]	6.5 [165]	6.5 [165]	3 [76]	3 [76]	—	0.75-(4) 0.81 dp	0.81-(4) thru	0.75-(2) 1 dp	0.75-(2) 1.06 dp	—	17 [433]	18.98 [492]	3.63 [92.1]	13.2 [336]	20 [508]	—		
8 × 6 [200 × 150]	26 [660.4]	—	6 [152]	6 [152]	4.25 [108]	7.75 [197]	15.4 [392]	15.4 [392]	14.1 [358]	2.36 [60]	6.5 [165]	6.5 [165]	3 [76]	3 [76]	—	0.75-(4) 0.81 dp	0.81-(4) thru	0.75-(2) 1 dp	0.75-(2) 1.06 dp	—	17 [433]	18.98 [492]	3.63 [92.1]	13.2 [336]	20 [508]	—		

## NUTRON 320F3 Valve Class 900/1500 Dimensions

Size, in [mm]	A		B	BB	D	E	J	JJ	K	ØL	ØM	MM	N	NN	P	ØQ	ØQQ	ØR	ØRR	S	T	U	V	W	ØX	Y	Z	
	RF	RJ																										
½ [13]	8.5 [215.9]	8.5 [215.9]	0.51 [13]	0.51 [13]	1.25 [31.8]	2.66 [67.6]	1.45 [36.9]	—	2.80 [71.1]	0.55 [13.9]	2.13 [54.1]	—	0.81 [20.6]	—	0.43 [10.9]	0.25-20 unc (4) 0.38 dp	—	0.19-(2) 0.31 dp	—	—	—	—	—	—	—	—	8 [203]	4.07 [103.4]
¾ × ½ [19 × 13]	9 [228.6]	9 [228.6]	0.51 [13]	0.76 [19.3]	1.25 [31.8]	2.66 [67.6]	1.45 [36.9]	—	2.80 [71.1]	0.55 [13.9]	2.13 [54.1]	—	0.81 [20.6]	—	0.43 [10.9]	0.25-20 unc (4) 0.38 dp	—	0.19-(2) 0.31 dp	—	—	—	—	—	—	—	—	8 [203]	4.07 [103.4]
¾ × ¾ [19 × 19]	9 [228.6]	9 [228.6]	0.76 [19.3]	0.76 [19.3]	1.76 [44.7]	3.37 [85.6]	2.01 [51.1]	—	3.62 [91.9]	0.71 [17.9]	2.76 [70.1]	—	1.21 [30.7]	—	0.55 [13.9]	0.25-20 unc (4) 0.44 dp	—	0.19-(2) 0.31 dp	—	—	—	—	—	—	—	—	10 [254]	5.11 [130]
1 × ¾ [25 × 19]	10 [254]	10 [254]	0.76 [19.3]	1.01 [25.7]	1.76 [44.7]	3.37 [85.6]	2.01 [51.1]	—	3.62 [91.9]	0.71 [17.9]	2.76 [70.1]	—	1.21 [30.7]	—	0.55 [13.9]	0.25-20 unc (4) 0.44 dp	—	0.19-(2) 0.31 dp	—	—	—	—	—	—	—	—	10 [254]	5.11 [130]
1 [25]	10 [254]	10 [254]	1.01 [25.7]	1.01 [25.7]	2.24 [56.9]	3.88 [98.6]	2.45 [62.2]	—	4.43 [112.5]	0.86 [21.9]	3.38 [85.9]	—	1.38 [34.9]	—	0.67 [16.9]	0.38-16 unc (4) 0.63 dp	—	0.25-(2) 0.38 dp	—	—	—	—	—	—	—	—	12 [305]	6.27 [159]
1½ [38]	12 [304.8]	12 [304.8]	1.51 [38.4]	1.51 [38.4]	2.5 [63.5]	4.38 [111.3]	2.92 [74.1]	—	5.16 [131.1]	1.1 [27.9]	4.02 [102.1]	—	1.63 [41.3]	—	0.86 [21.9]	0.38-16 unc (4) 0.63 dp	—	0.31-(2) 0.38 dp	—	—	—	—	—	—	—	—	16 [406]	6.77 [172]
2 × 1½ [50 × 38]	14.5 [368.3]	14.62 [371.3]	1.51 [38.4]	2.03 [51.6]	2.5 [63.5]	4.38 [111.3]	2.92 [74.1]	—	5.16 [131.1]	1.1 [27.9]	4.02 [102.1]	—	1.63 [41.3]	—	0.86 [21.9]	0.38-16 unc (4) 0.63 dp	—	0.31-(2) 0.38 dp	—	—	—	—	—	—	—	—	16 [406]	6.77 [172]
2 [50]	14.5 [368.3]	14.62 [371.3]	2.03 [51.6]	2.03 [51.6]	3 [76.2]	5.38 [136.7]	4.01 [101.9]	8.64 [219.5]	6.79 [172.5]	1.41 [35.9]	4.92 [125]	4.92 [125]	1.94 [49.3]	1.94 [49.3]	1.06 [26.9]	0.5-13 unc (4) 0.63 dp	0.56-(4) thru	0.44-(2) 0.63 dp	0.44-(2) 0.63 dp	—	10.14 [258]	11.74 [298]	1.94 [49.3]	11.19 [284]	12 [305]	24 [610]	9.47 [240.5]	
3 × 2 [80 × 50]	18.5 [469.9]	18.62 [472.9]	2.03 [51.6]	3.03 [77]	3 [76.2]	5.38 [136.7]	4.01 [101.9]	8.64 [219.5]	6.79 [172.5]	1.41 [35.9]	4.92 [125]	4.92 [125]	1.94 [49.3]	1.94 [49.3]	1.06 [26.9]	0.5-13 unc (4) 0.63 dp	0.56-(4) thru	0.44-(2) 0.63 dp	0.44-(2) 0.63 dp	—	10.14 [258]	11.74 [298]	1.94 [49.3]	11.19 [284]	12 [305]	24 [610]	9.47 [240.5]	

# Dimensions 320F3

## NUTRON 320F3 Valve Class 2500 Dimensions

Size, in [mm]	A		B	BB	D	E	J	JJ	K	ØL	ØM	MM	N	NN	P	ØQ	ØQQ	ØR	ØRR	S	T	U	V	W	ØX	Y	Z	
	RF	RJ													FLATS													
½ [13]	10.38 [263.7]	10.38 [263.7]	0.51 [13.0]	0.51 [13.0]	1.25 [31.8]	2.66 [67.6]	1.45 [36.9]	—	2.8 [71.1]	0.55 [13.9]	2.13 [54.1]	—	0.81 [20.6]	—	0.43 [10.9]	0.25-20 unc (4) 0.38 dp	—	0.19-(2) 0.31 dp	—	—	—	—	—	—	—	—	8 [203]	4.07 [103.4]
¾ × ½ [19 × 13]	10.75 [273.1]	10.75 [273.1]	0.51 [13]	0.76 [19.3]	1.25 [31.8]	2.66 [67.6]	1.45 [36.9]	—	2.8 [71.1]	0.55 [13.9]	2.13 [54.1]	—	0.81 [20.6]	—	0.43 [10.9]	0.25-20 unc (4) 0.38 dp	—	0.19-(2) 0.31 dp	—	—	—	—	—	—	—	—	8 [203]	4.07 [103.4]
¾ × ¾	10.75 [273.1]	10.75 [273.1]	0.76 [19.3]	0.76 [19.3]	1.76 [44.7]	3.37 [85.6]	2.01 [51.1]	—	3.62 [91.9]	0.71 [17.9]	2.76 [70.1]	—	1.21 [30.7]	—	0.55 [13.9]	0.25-20 unc (4) 0.44 dp	—	0.19-(2) 0.31 dp	—	—	—	—	—	—	—	—	10 [254]	5.11 [130]
1 × ¾ [25 × 19]	12.13 [308.1]	12.13 [308.1]	0.76 [19.3]	1.01 [25.7]	1.76 [44.7]	3.37 [85.6]	2.01 [51.1]	—	3.62 [91.9]	0.71 [17.9]	2.76 [70.1]	—	1.21 [30.7]	—	0.55 [13.9]	0.25-20 unc (4) 0.44 dp	—	0.19-(2) 0.31 dp	—	—	—	—	—	—	—	—	10 [254]	5.11 [130]
1 [25]	12.13 [308.1]	12.13 [308.1]	1.01 [25.7]	1.01 [25.7]	2.24 [56.9]	3.88 [98.6]	2.49 [63.2]	—	4.43 [112.5]	0.86 [21.9]	3.38 [85.9]	—	1.38 [34.9]	—	0.67 [16.9]	0.38-16 unc (4) 0.63 dp	—	0.25-(2) 0.38 dp	—	—	—	—	—	—	—	—	12 [305]	6.27 [159]
1½ [38]	15.13 [384.3]	15.13 [384.3]	1.51 [38.4]	1.51 [38.4]	2.50 [63.5]	4.38 [111.3]	2.92 [74.1]	6.42 [163.1]	5.16 [131.1]	1.1 [27.9]	4.02 [102.1]	4.02 [102.1]	1.63 [41.3]	1.63 [41.3]	0.86 [21.9]	0.38-16 (4) 0.63 dp	0.44-(4) thru	0.31-(2) 0.38 dp	0.31-(2) 0.53 dp	—	7.5 [191]	8.76 [222]	1.75 [44.5]	9.08 [231]	6 [152]	16 [406]	6.77 [172]	
2 × 1½ [50 × 38]	17.75 [453.9]	17.87 [453.9]	1.51 [38.4]	1.76 [44.7]	2.50 [63.5]	4.38 [111.3]	2.92 [74.1]	6.42 [163.1]	5.16 [131.1]	1.1 [27.9]	4.02 [102.1]	4.02 [102.1]	1.63 [41.3]	1.63 [41.3]	0.86 [21.9]	0.38-16 (4) 0.63 dp	0.44-(4) thru	0.31-(2) 0.38 dp	0.31-(2) 0.53 dp	—	7.5 [191]	8.76 [222]	1.75 [44.5]	9.08 [231]	6 [152]	16 [406]	6.77 [172]	

# Dimensional Data— $\frac{1}{2}$ -in Full Port Through 8-in $\times$ 4-in Reduced Port 320B3

$\frac{1}{2}$ -in full port through 8-in  $\times$  4-in reduced port ASME Classes 800 through 2500

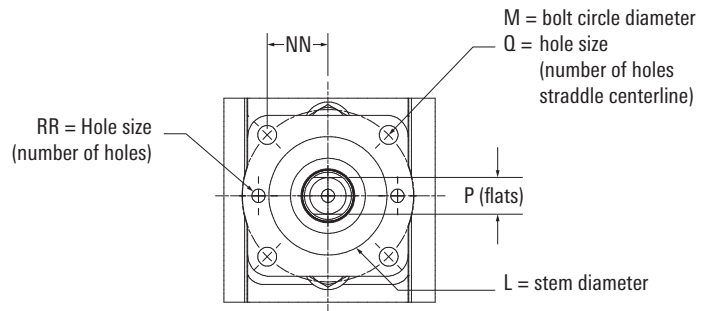
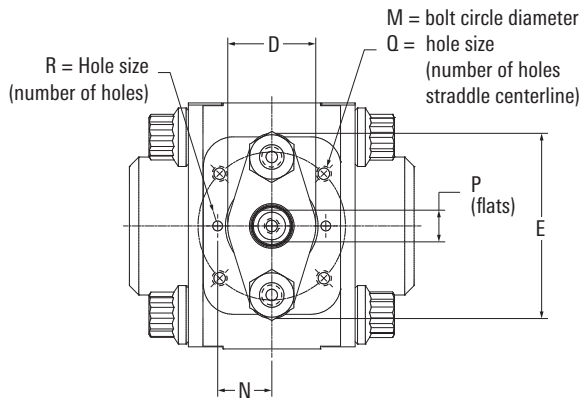

1.5-in  $\times$  2-in 2500 above with bracket.

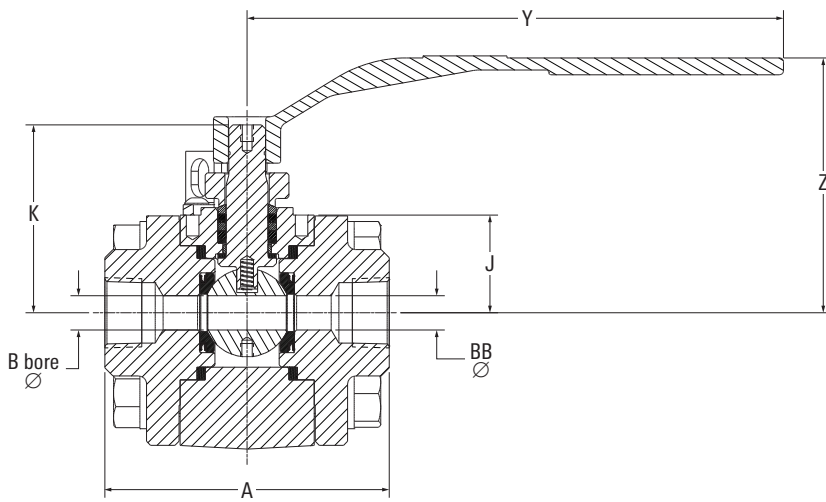

Valve with wrench (lever).

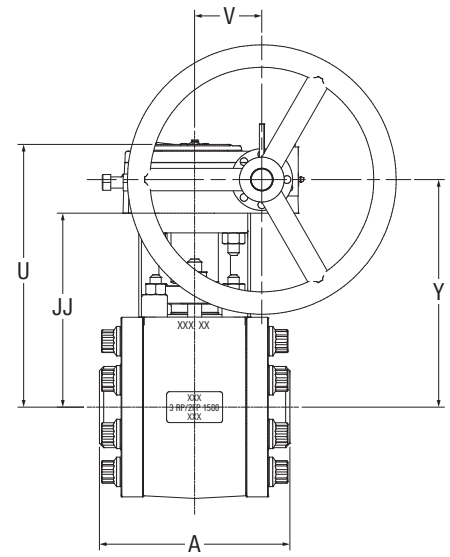

Valve with gear.

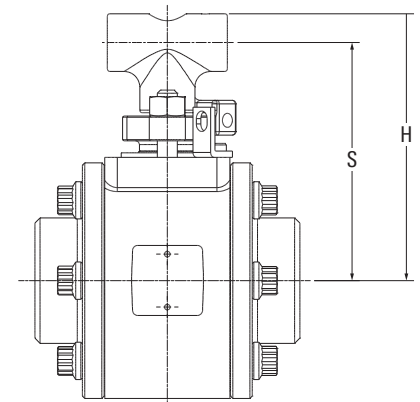
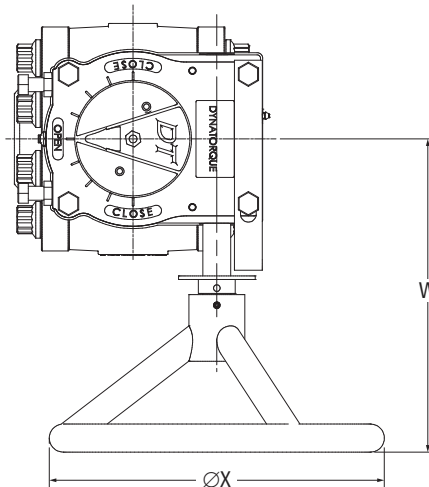
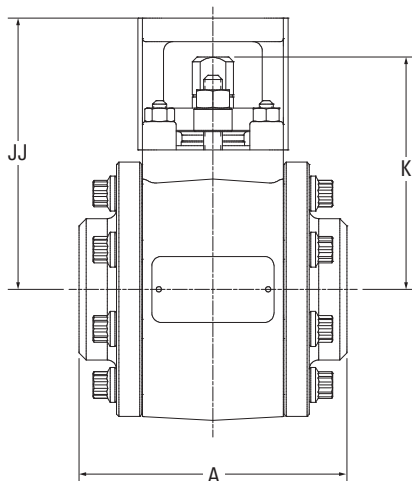

Valve with wrench hand.

# Dimensions 320B3

## NUTRON 320B3 Valve Class 800 Dimensions

Size, in [mm]	A	B	BB	D	E	J	JJ	K	ØL	ØM	MM	N	NN	P	ØQ	ØQQ	ØR	ØRR	T	U	V	W	ØX	Y	Z
½ [13]	3.6 [91.9]	0.5 [13]	0.5 [13]	1.1 [28.4]	2.4 [59.7]	1.5 [38.4]	—	2.7 [67.6]	0.5 [11.9]	1.9 [47.6]	—	0.7 [17.5]	—	0.4 [8.9]	10-24 unc (4) 0.38 dp	—	0.13-(2) 0.19 dp	—	—	—	—	—	—	6 [152.4]	3.5 [89.7]
¾ × ½ [19 × 13]	4.2 [107.7]	0.5 [13]	0.8 [19.3]	1.1 [28.4]	2.4 [59.7]	1.5 [38.4]	—	2.7 [67.6]	0.5 [11.9]	1.9 [47.6]	—	0.7 [17.5]	—	0.4 [8.9]	10-24 unc (4) 0.38 dp	—	0.13-(2) 0.19 dp	—	—	—	—	—	—	6 [152.4]	3.5 [89.7]
¾ × ¾ [19 × 19]	4.2 [107.7]	0.8 [19.3]	0.8 [19.3]	1.3 [31.8]	2.7 [67.6]	1.8 [45.7]	—	3.3 [84.8]	0.5 [13.9]	2.1 [54.1]	—	0.8 [20.6]	—	0.4 [10.9]	0.25-20 unc (4) 0.44 dp	—	0.19-(2) 0.31 dp	—	—	—	—	—	—	8 [203.2]	4.5 [113]
1 × ¾ [25 × 19]	5 [127]	0.8 [19.3]	1 [25.7]	1.3 [31.8]	2.7 [67.6]	1.8 [45.7]	—	3.3 [84.8]	0.5 [13.9]	2.1 [54.1]	—	0.8 [20.6]	—	0.4 [10.9]	0.25-20 unc (4) 0.44 dp	—	0.19-(2) 0.31 dp	—	—	—	—	—	—	8.0 [203.2]	4.5 [113]
1 [25]	5 [127]	1 [25.7]	1 [25.7]	1.8 [44.7]	3.4 [85.6]	2.4 [60.7]	—	4.1 [104.1]	0.7 [17.9]	2.8 [70.1]	—	1.2 [30.7]	—	0.5 [13.9]	0.25-20 unc (4) 0.44 dp	—	0.19-(2) 0.31 dp	—	—	—	—	—	—	10 [254]	5.5 [139.2]
1½ [38]	6.6 [168.4]	1.5 [38.4]	1.5 [38.4]	2.2 [56.9]	3.9 [98.6]	3.1 [78.1]	—	5.3 [133.6]	0.9 [21.9]	3.4 [85.9]	—	1.4 [34.9]	—	0.7 [16.9]	0.38-16 unc (4) 0.63 dp	—	0.25-(2) 0.38 dp	—	—	—	—	—	—	12 [304.8]	6.9 [174]
2 × 1½ [50 × 38]	7.6 [193.8]	1.5 [38.4]	2 [51.6]	2.2 [56.9]	3.9 [98.6]	3.1 [78.1]	—	5.3 [133.6]	0.9 [21.9]	3.4 [85.9]	—	1.4 [34.9]	—	0.7 [16.9]	0.38-16 unc (4) 0.63 dp	—	0.25-(2) 0.38 dp	—	—	—	—	—	—	12 [304.8]	6.9 [174]
2 [50]	7.1 [181.1]	2.0 [51.6]	2 [51.6]	2.5 [63.5]	4.4 [111.3]	3.7 [94]	7.2 [182.9]	6.2 [156.5]	1.1 [27.9]	4 [102.1]	4 [102.1]	1.6 [41.3]	1.6 [41.3]	0.9 [21.9]	0.38-16 unc (4) 0.63 dp	0.44-(4) thru	0.31-(2) 0.38 dp	0.31-(2) 0.38 dp	8.3 [210.8]	9.5 [242.3]	1.8 [44.5]	9.1 [230.6]	6 [152.4]	16 [406.4]	7.6 [192]
3 × 2 [80 × 50]	9.3 [235]	2 [51.6]	3 [77]	2.5 [63.5]	4.4 [111.3]	3.7 [94]	—	6.2 [156.5]	1.1 [27.9]	4 [102.1]	—	1.6 [41.3]	—	0.9 [21.9]	0.38-16 unc (4) 0.63 dp	—	0.31-(2) 0.38 dp	—	—	—	—	—	—	—	7.6 [184.6]
3 [80]	9.6 [244.3]	3 [77]	3 [77]	3 [76.2]	5.4 [136.7]	5.1 [130.5]	9.8 [247.9]	8.6 [217.7]	1.4 [35.9]	4.9 [125]	4.9 [125]	1.9 [49.3]	1.9 [49.3]	1.1 [26.9]	0.5-13 unc (4) 0.75 dp	0.56-(4) thru	0.44-(2) 0.63 dp	0.43-(2) 0.63 dp	11.1 [282.7]	12.5 [316.9]	2.5 [63.8]	12.2 [309.9]	12 [304.8]	24 [609.6]	10.6 [269.7]
4 × 3 [100 × 80]	11.4 [289.1]	3 [77]	4 [102.4]	3 [76.2]	5.4 [136.7]	5.1 [130.5]	9.8 [247.9]	8.6 [217.7]	1.4 [35.9]	4.9 [125]	4.9 [125]	1.9 [49.3]	1.9 [49.3]	1.1 [26.9]	0.5-13 unc (4) 0.75 dp	0.56-(4) thru	0.44-(2) 0.63 dp	0.43-(2) 0.63 dp	11.1 [282.7]	12.5 [316.9]	2.5 [63.8]	12.2 [309.9]	12 [304.8]	24 [609.6]	10.6 [269.7]

## NUTRON 320B3 Valve Class 900/1500 Dimensions

Size, in [mm]	A	B	BB	D	E	J	JJ	K	ØL	ØM	MM	N	NN	P	ØQ	ØQQ	ØR	ØRR	T	U	V	W	ØX	Y	Z
½ [13]	4.3 [108]	0.5 [13]	0.5 [13.0]	1.3 [31.8]	2.7 [67.6]	1.5 [36.9]	—	2.8 [71.1]	0.5 [13.9]	2.1 [54.1]	—	0.8 [20.6]	—	0.4 [10.9]	0.25-20 unc (4) 0.38 dp	—	0.19-(2) 0.31 dp	—	—	—	—	—	—	8 [203.2]	4.1 [103.4]
¾ × ½ [19 × 13]	4.3 [108]	0.5 [13]	0.8 [19.3]	1.3 [31.8]	2.7 [67.6]	1.5 [36.9]	—	2.8 [71.1]	0.5 [13.9]	2.1 [54.1]	—	0.8 [20.6]	—	0.4 [10.9]	0.25-20 unc (4) 0.38 dp	—	0.19-(2) 0.31 dp	—	—	—	—	—	—	8 [203.2]	4.1 [103.4]
¾ × ¾ [19 × 19]	5 [127]	0.8 [19.3]	0.8 [19.3]	1.8 [44.7]	3.4 [85.6]	2 [51.1]	—	3.6 [91.9]	0.7 [17.9]	2.8 [70.1]	—	1.2 [30.7]	—	0.5 [13.9]	0.25-20 unc (4) 0.44 dp	—	0.19-(2) 0.31 dp	—	—	—	—	—	—	10 [254]	5.1 [129.8]
1 × ¾ [25 × 19]	5 [127]	0.8 [19.3]	1 [25.7]	1.8 [44.7]	3.4 [85.6]	2 [51.1]	—	3.6 [91.9]	0.7 [17.9]	2.8 [70.1]	—	1.2 [30.7]	—	0.5 [13.9]	0.25-20 unc (4) 0.44 dp	—	0.19-(2) 0.31 dp	—	—	—	—	—	—	10 [254]	5.1 [129.8]
1 [25]	6.1 [153.9]	1 [25.7]	1 [25.7]	2.2 [56.9]	3.9 [98.6]	2.4 [62.2]	—	4.4 [112.5]	0.9 [21.9]	3.4 [85.9]	—	1.4 [34.9]	—	0.7 [16.9]	0.38-16 unc (4) 0.63 dp	—	0.25-(2) 0.38 dp	—	—	—	—	—	—	12 [304.8]	6.3 [159.5]
1½ [38]	7.3 [184.2]	1.5 [38.4]	1.5 [38.4]	2.5 [63.5]	4.4 [111.3]	2.9 [74.1]	—	5.2 [131.1]	1.1 [27.9]	4 [102.1]	—	1.6 [41.3]	—	0.9 [21.9]	0.38-16 unc (4) 0.63 dp	—	0.31-(2) 0.38 dp	—	—	—	—	—	—	16 [406.4]	6.7 [170.7]
2 × 1½ [50 × 38]	7.3 [184.2]	1.5 [38.4]	2 [51.6]	2.5 [63.5]	4.4 [111.3]	2.9 [74.1]	—	5.2 [131.1]	1.1 [27.9]	4 [102.1]	—	1.6 [41.3]	—	0.9 [21.9]	0.38-16 unc (4) 0.63 dp	—	0.31-(2) 0.38 dp	—	—	—	—	—	—	16 [406.4]	6.7 [170.7]
2 [50]	8.5 [215.9]	2 [51.6]	2 [51.6]	3 [76.2]	5.4 [136.7]	4 [101.9]	8.6 [219.5]	6.8 [172.5]	1.4 [35.9]	4.9 [125]	4.9 [125]	1.9 [49.3]	1.9 [49.3]	1.1 [26.9]	0.5-13 unc (4) 0.63 dp	0.56-(4) thru	0.49-(2) 0.63 dp	0.44-(2) 0.63 dp	10.1 [257.6]	11.7 [298.1]	1.9 [49.3]	11.2 [284.2]	12 [304.8]	24 [609.6]	9.5 [240.5]
3 × 2 [80 × 50]	10.8 [274.6]	2 [51.6]	3 [77]	3 [76.2]	5.4 [136.7]	4 [101.9]	8.6 [219.5]	6.8 [172.5]	1.4 [35.9]	4.9 [125]	4.9 [125]	1.9 [49.3]	1.9 [49.3]	1.1 [26.9]	0.5-13 unc (4) 0.63 dp	0.56-(4) thru	0.49-(2) 0.63 dp	0.44-(2) 0.63 dp	10.1 [257.6]	11.7 [298.1]	1.9 [49.3]	11.2 [284.2]	12 [304.8]	24 [609.6]	9.5 [240.5]

# Dimensions 320B3

## NUTRON 320B3 Valve Class 2500 Dimensions

Size, in [mm]	A	B	BB	D	E	J	JJ	K	ØL	ØM	MM	N	NN	P	ØQ	ØQQ	ØR	ØRR	T	U	V	W	ØX	Y	Z
½ [13]	4.3 [108]	0.5 [13]	0.5 [13]	1.3 [31.8]	2.7 [67.6]	1.5 [36.9]	–	2.8 [71.1]	0.5 [13.9]	2.1 [54.1]	–	0.8 [20.6]	–	0.4 [10.9]	0.25-20 unc (4) 0.38 dp	–	0.19 (2) 0.31 dp	–	–	–	–	–	–	8 [203.2]	4.1 [103.4]
¾ × ½ [19 × 13]	4.3 [108]	0.5 [13]	0.8 [19.3]	1.3 [31.8]	2.7 [67.6]	1.5 [36.9]	–	2.8 [71.1]	0.5 [13.9]	2.1 [54.1]	–	0.8 [20.6]	–	0.4 [10.9]	0.25-20 unc (4) 0.38 dp	–	0.19 (2) 0.31 dp	–	–	–	–	–	–	8 [203.2]	4.1 [103.4]
¾ × ¾ [19 × 19]	5.3 [138]	0.8 [19.3]	0.8 [19.3]	1.8 [44.7]	3.4 [85.6]	2 [51.1]	–	3.6 [91.9]	0.7 [17.9]	2.8 [70.1]	–	1.2 [30.7]	–	0.5 [13.9]	0.25-20 unc (4) 0.44 dp	–	0.19 (2) 0.31 dp	–	–	–	–	–	–	10 [254]	5.1 [129.8]
1 × ¾ [25 × 19]	5.5 [140]	0.8 [19.3]	1 [25.7]	1.8 [44.7]	3.4 [85.6]	2 [51.1]	–	3.6 [91.9]	0.7 [17.9]	2.8 [70.1]	–	1.2 [30.7]	–	0.5 [13.9]	0.25-20 unc (4) 0.44 dp	–	0.19 (2) 0.31 dp	–	–	–	–	–	–	10 [254]	5.1 [129.8]
1 [25]	6.3 [159]	1 [25.7]	1 [25.7]	2.2 [56.9]	3.9 [98.6]	2.5 [63.2]	–	4.4 [112.5]	0.9 [21.9]	3.4 [85.9]	–	1.4 [34.9]	–	0.7 [16.9]	0.38-16 unc (4) 0.63 dp	–	0.25 (2) 0.38 dp	–	–	–	–	–	–	12 [304.8]	6.3 [159.3]
1½ [38]	7.5 [191]	1.5 [38.4]	1.5 [38.4]	2.5 [63.5]	4.4 [111.3]	2.9 [74.1]	6.4 [163.1]	5.2 [131.1]	1.1 [27.9]	4 [102.1]	4 [102.1]	1.6 [41.3]	1.6 41.3	0.9 [21.9]	0.38-16 (4) 0.63 dp	0.44-(4) thru	0.31 (2) 0.38 dp	0.31 (2) 0.53 dp	7.5 [191.1]	8.8 [222.5]	1.8 [44.5]	9.1 [230.6]	6 [152.4]	16 [406.4]	6.8 [172]
2 × 1½ [50 × 38]	7.8 [197]	1.5 [38.4]	1.8 [44.7]	2.5 [63.5]	4.4 [111.3]	2.9 [74.1]	6.4 [163.1]	5.2 [131.1]	1.1 [27.9]	4 [102.1]	4 [102.1]	1.6 [41.3]	1.6 41.3	0.9 [21.9]	0.38-16 (4) 0.63 dp	0.44-(4) thru	0.31 (2) 0.38 dp	0.31 (2) 0.53 dp	7.5 [191.1]	8.8 [222.5]	1.8 [44.5]	9.1 [230.6]	6 [152.4]	16 [406.4]	6.8 [172]

# Torque Estimation and MAST

Size, in [mm]	Class	Gauge Pressure	Valve Torque Peek Seat, Graphite Packing		MAST for 36K yield
			Break	Run	
1 × 1 [25 × 25]	600	741–1,480	343	202	881.0
1 × 1 [25 × 25]	800	80–2,000	381	210	881.0
1 × 1 [25 × 25]	900	1,481–2,220	488	286	1,548.5
1 × 1 [25 × 25]	1500	2,221–3,705	609	325	1,548.5
1 × 1 [25 × 25]	2500	3,706–6,170	897	499	1,548.5
1.5 × 1.5 [40 × 40]	600	741–1,480	860	437	1,548.5
1.5 × 1.5 [40 × 40]	800	80–2,000	969	457	1,548.5
1.5 × 1.5 [40 × 40]	900	1,481–2,220	1,090	506	3,290.4
1.5 × 1.5 [40 × 40]	1500	2,221–3,705	1,404	584	3,290.4
1.5 × 1.5 [40 × 40]	2500	3,706–6,170	2,035	884	3,290.4
2 × 2 [50 × 50]	600	741–1,480	1,639	742	3,290.4
2 × 2 [50 × 50]	800	80–2,000	1,867	781	3,290.4
2 × 2 [50 × 50]	900	1,481–2,220	2,259	1,014	6,943.6
2 × 2 [50 × 50]	1500	2,221–3,705	2,921	1,174	6,943.6
3 × 3 [80 × 80]	600	741–1,480	4,254	1,596	6,943.6
3 × 3 [80 × 80]	800	80–2,000	4,912	1,694	6,943.6
4 × 4 [100 × 100]	600	741–1,480	8,608	3,018	16,747.0
6 × 6 [150 × 150]	600	741–1,480	22,752	6,598	40,040.0

# Weights 320F3

320F3 Weights		BARE STEM, lb [kg]				
Size, in [mm]	600 RF	600 RJ	1500 RF	1500 RJ	2500 RF	2500 RJ
½ [13]	10.0 [4.5]	11.0 [5]	19.9 [9]	21.7 [9.8]	28.0 [12.7]	30.3 [13.7]
¾ × ½ [19 × 13]	13.3 [6.1]	15.0 [6.8]	22.7 [10.3]	24.8 [11.2]	30.2 [13.7]	32.7 [14.8]
¾ × ¾ [19 × 19]	16.6 [7.5]	18.2 [8.3]	29.6 [13.4]	31.6 [14.3]	37.5 [17]	40.0 [18.1]
1 × ¾ [25 × 19]	19.3 [8.8]	21.1 [9.6]	35.7 [16.2]	38.4 [17.4]	45.0 [20.4]	48.1 [21.8]
1 [25]	28.7 [13]	30.4 [13.8]	45.6 [20.7]	48.1 [21.8]	65.4 [29.6]	68.6 [31.1]
1½ [38]	49.9 [22.6]	52.3 [23.7]	76.6 [34.7]	80.2 [36.4]	120.6 [54.7]	127.0 [57.6]
2 × 1½ [50 × 38]	56.1 [25.4]	59.3 [26.9]	102.9 [46.7]	108.0 [49]	152.6 [69.2]	160.7 [72.9]
2 [50]	74.9 [34]	77.9 [35.3]	148.0 [67.1]	154.6 [70.1]	–	–
3 × 2 [80 × 50]	98.0 [44.4]	102.7 [46.6]	195.9 [88.8]	205.5 [93.2]	–	–
3 [80]	150.9 [68.5]	155.5 [70.5]	–	–	–	–
4 × 3 [100 × 80]	205.3 [93.1]	214.4 [97.3]	–	–	–	–

320F3 Weights		WRENCH, lb [kg]				
Size, in [mm]	600 RF	600 RJ	1500 RF	1500 RJ	2500 RF	2500 RJ
½ [13]	10.3 [4.7]	11.4 [5.2]	20.5 [9.3]	22.3 [10.1]	28.6 [13]	30.9 [14]
¾ × ½ [19 × 13]	13.7 [6.2]	15.3 [7]	23.3 [10.6]	25.4 [11.5]	30.8 [14]	33.3 [15.1]
¾ × ¾ [19 × 19]	17.2 [7.8]	18.8 [8.5]	30.6 [13.9]	32.7 [14.8]	38.6 [17.5]	41.1 [18.6]
1 × ¾ [25 × 19]	19.9 [9]	21.7 [9.8]	36.8 [16.7]	39.5 [17.9]	46.0 [20.9]	49.2 [22.3]
1 [25]	29.7 [13.5]	31.5 [14.3]	47.6 [21.6]	50.1 [22.7]	67.4 [30.6]	70.6 [32]
1½ [38]	51.9 [23.6]	54.2 [24.6]	79.4 [36]	83.1 [37.7]	123.5 [56]	129.8 [58.9]
2 × 1½ [50 × 38]	58.1 [26.4]	61.3 [27.8]	105.7 [47.9]	110.9 [50.3]	155.4 [70.5]	163.5 [74.2]
2 [50]	77.7 [35.3]	80.7 [36.6]	154.7 [70.2]	161.4 [73.2]	–	–
3 × 2 [80 × 50]	100.8 [45.7]	105.5 [47.9]	202.6 [91.9]	212.2 [96.2]	–	–
3 [80]	157.7 [71.5]	162.2 [73.6]	–	–	–	–
4 × 3 [100 × 80]	212.0 [96.2]	221.2 [100.3]	–	–	–	–

320F3 Weights		LESS GEAR, lb [kg]				
Size, in [mm]	600 RF	600 RJ	1500 RF	1500 RJ	2500 RF	2500 RJ
1½ [38]	–	–	–	–	125 [56.7]	131.3 [59.6]
2 × 1½ [50 × 38]	–	–	–	–	156.9 [71.2]	165 [74.8]
2 [50]	79.2 [35.9]	82.2 [37.3]	157.9 [71.6]	164.5 [74.6]	–	–
3 × 2 [80 × 50]	–	–	205.7 [93.3]	215.3 [97.7]	–	–
3 [80]	160.8 [72.9]	165.4 [75]	–	–	–	–
4 × 3 [100 × 80]	215.1 [97.6]	224.3 [101.7]	–	–	–	–

320F3 Weights		WORM GEAR, lb [kg]				
Size, in [mm]	600 RF	600 RJ	1500 RF	1500 RJ	2500 RF	2500 RJ
1½ [38]	–	–	–	–	136.6 [69]	142.9 [64.8]
2 × 1½ [50 × 38]	–	–	–	–	168.5 [76.4]	176.6 [80.1]
2 [50]	90.8 [41.2]	93.8 [42.5]	193.3 [87.7]	199.9 [90.7]	–	–
3 × 2 [80 × 50]	–	–	241.1 [109.4]	250.7 [113.7]	–	–
3 [80]	183.7 [83.3]	188.2 [85.4]	–	–	–	–
4 × 3 [100 × 80]	243.8 [110.6]	253.3 [114.9]	–	–	–	–

# Weights 320B3

320B3 Weights		BARE STEM, lb [kg]		
Size, in [mm]	800	1500	2500	
½ [13]	6.2 [2.81]	10.8 [4.9]	12.6 [5.7]	
¾ × ½ [19 × 13]	6.6 [2.99]	10.6 [4.8]	12.5 [5.7]	
¾ × ¾ [19 × 19]	10.1 [4.6]	17.8 [8.06]	19.9 [9]	
1 × ¾ [25 × 19]	10.6 [4.8]	17.5 [7.9]	19.7 [8.9]	
1 [25]	20.5 [9.3]	29.2 [13.2]	41.7 [18.9]	
1½ [38]	35.9 [16.3]	50.8 [23]	50.8 [23]	
2 × 1½ [50 × 38]	38.3 [17.3]	50.7 [23]	69.2 [31.3]	
2 [50]	55.0 [24.9]	96.7 [43.8]	–	
3 × 2 [80 × 50]	59.5 [27.0]	105.6 [47.8]	–	
3 [80]	119.0 [53.9]	–	–	
4 × 3 [100 × 80]	122.9 [55.7]	–	–	

320B3 Weights		WRENCH, lb [kg]		
Size, in [mm]	800	1500	2500	
½ [13]	6.6 [3]	11.4 [5.2]	13.2 [6]	
¾ × ½ [19 × 13]	6.6 [3]	11.2 [5.1]	11.2 [5.1]	
¾ × ¾ [19 × 19]	10.7 [4.8]	18.8 [8.5]	21.0 [9.5]	
1 × ¾ [25 × 19]	11.2 [5.1]	18.5 [8.4]	20.8 [9.4]	
1 [25]	21.6 [9.8]	31.2 [14.1]	43.7 [19.8]	
1½ [38]	37.9 [17.2]	53.7 [24.3]	72.3 [32.8]	
2 × 1½ [50 × 38]	40.3 [18.3]	53.6 [24.3]	72.0 [32.6]	
2 [50]	57.8 [26.2]	103.5 [46.9]	–	
3 × 2 [80 × 50]	62.3 [28.2]	112.3 [50.9]	–	
3 [80]	125.7 [56.9]	–	–	
4 × 3 [100 × 80]	129.6 [58.7]	–	–	

320B3 Weights		WRENCH HEAD, lb [kg]		
	800	1500	2500	
3 [80]	125.8 [57]	–	–	
4 × 3 [100 × 80]	134.8 [61.1]	–	–	

320B3 Weights		LESS GEAR, lb [kg]		
	800	1500	2500	
1½ [38]	–	–	125 [56.6]	
2 × 1½ [50 × 38]	–	–	157.1 [71.2]	
2 [50]	–	157.9 [71.5]	–	
3 × 2 [80 × 50]	–	115.5 [52.3]	–	
3 [80]	151.7 [68.7]	–	–	
4 × 3 [100 × 80]	132.8 [60.2]	–	–	

320B3 Weights		WORM GEAR, lb [kg]		
	800	1500	2500	
1½ [38]	–	–	85.3 [38.6]	
2 × 1½ [50 × 38]	–	–	168.6 [76.4]	
2 [50]	–	193.3 [87.6]	–	
3 × 2 [80 × 50]	–	150.8 [68.3]	–	
3 [80]	151.7 [68.7]	–	–	
4 × 3 [100 × 80]	155.6 [70.5]	–	–	

# NUTRON 320F3/B3 forged floating ball valves



[cameron.slb.com/valves](http://cameron.slb.com/valves)

\*Mark of Schlumberger  
Other company, product, and service names  
are the properties of their respective owners.  
Copyright © 2020 Schlumberger. All rights reserved. 19-VL-538043

 **CAMERON**  
A Schlumberger Company